

OPG's DEEP GEOLOGIC

# REPOSITORY

FOR LOW & INTERMEDIATE LEVEL WASTE

## Reference Low and Intermediate Level Waste Inventory for the Deep Geologic Repository

December 2010

Prepared by: Ontario Power Generation, Inc.

00216-REP-03902-00003-R003



OPG's DEEP GEOLOGIC

# **REPOSITORY**

FOR LOW & INTERMEDIATE LEVEL WASTE

## **Reference Low and Intermediate Level Waste Inventory for the Deep Geologic Repository**

December 2010

Prepared by: Ontario Power Generation, Inc.

00216-REP-03902-00003-R003

**THIS PAGE HAS BEEN LEFT BLANK INTENTIONALLY**

OPG Proprietary	
Document Number: <b>00216-REP-03902-00003</b>	Usage Classification: <b>INFORMATION</b>
Sheet Number: <b>N/A</b>	Revision: <b>R003</b>

Title:

**REFERENCE LOW- AND INTERMEDIATE-LEVEL WASTE INVENTORY FOR THE DEEP  
GEOLOGIC REPOSITORY**

© Ontario Power Generation Inc., 2010. This document has been produced and distributed for Ontario Power Generation Inc. purposes only. No part of this document may be reproduced, published, converted, or stored in any data retrieval system, or transmitted in any form or by any means (electronic, mechanical, photocopying, recording, or otherwise) without the prior written permission of Ontario Power Generation Inc.

**REFERENCE LOW- AND  
INTERMEDIATE-LEVEL WASTE  
INVENTORY FOR THE DEEP  
GEOLOGIC REPOSITORY****00216-REP-03902-00003-R003**

2010-12-17

Order Number: N/A

Other Reference Number: N/A

**OPG Proprietary**

Prepared by: F. Rodrigues  
Sr. Technical Engineer  
Conceptual Design and  
System Planning

Recommended by: D. Gibson  
Section Manager  
Conceptual Design and  
System Planning

Reviewed by: M. Kaya  
Asst. Technical Engineer  
Conceptual Design and  
System Planning

Approved by: G. Sullivan  
Manager  
Conceptual Design and  
System Planning

Report

OPG Proprietary		
Document Number:	00216-REP-03902-00003	Usage Classification: <b>INFORMATION</b>
Sheet Number:	Revision Number: <b>R003</b>	Page: <b>2 of 136</b>

Title:

**REFERENCE LOW- AND INTERMEDIATE-LEVEL WASTE INVENTORY FOR THE DEEP GEOLOGIC REPOSITORY**

**Table of Contents**

	<b>Page</b>
List of Tables and Figures.....	4
Revision Summary.....	6
Executive Summary.....	7
<b>1.0 INTRODUCTION.....</b>	<b>8</b>
1.1 Purpose.....	8
1.2 Background.....	8
1.3 Objectives and Scope.....	9
<b>2.0 PROJECTED OPERATIONAL LOW- AND INTERMEDIATE-LEVEL WASTE INVENTORY AND CHARACTERISTICS.....</b>	<b>10</b>
2.1 Waste Volumes and Package Inventory.....	10
2.2 Radionuclide Inventory.....	10
2.3 Chemical Inventory.....	14
2.4 Bulk Material Inventory.....	14
<b>3.0 PROJECTED RETUBE AND STEAM GENERATOR REFURBISHMENT WASTE INVENTORY AND CHARACTERISTICS.....</b>	<b>28</b>
3.1 Waste Volumes and Package Inventory.....	28
3.2 Radionuclide Inventory.....	29
3.3 Chemical Inventory.....	34
3.4 Bulk Material Inventory.....	34
<b>4.0 TOTAL OPERATIONAL AND REFURBISHMENT LOW- AND INTERMEDIATE-LEVEL WASTE INVENTORY.....</b>	<b>36</b>
4.1 Total Low- and Intermediate-Level Waste Volume.....	36
4.2 Total Radioactivity.....	40
<b>5.0 CONCLUSION.....</b>	<b>44</b>
<b>6.0 ACKNOWLEDGEMENTS.....</b>	<b>45</b>
<b>7.0 REFERENCES.....</b>	<b>46</b>

**Report**

<b>OPG Proprietary</b>		
Document Number: <b>00216-REP-03902-00003</b>		Usage Classification: <b>INFORMATION</b>
Sheet Number: <b>N/A</b>	Revision Number: <b>R003</b>	Page: <b>3 of 136</b>

Title:

**REFERENCE LOW- AND INTERMEDIATE-LEVEL WASTE INVENTORY FOR THE DEEP GEOLOGIC REPOSITORY**

**APPENDICES**

Appendix A: Technical Assumptions.....	48
Appendix B: Specific Activities of Operational and Refurbishment Low- and Intermediate-Level Waste .....	53
Appendix C: Chemical and Physical Characteristics of Operational and Refurbishment Low- and Intermediate-Level Waste.....	59
Appendix D: Uncertainties Associated with Concentrations of Radionuclides and Chemicals in Low- and Intermediate-Level Waste.....	67
Appendix E: Reference Deep Geological Repository Data Sheets .....	74
Glossary .....	134

OPG Proprietary		
Document Number:	00216-REP-03902-00003	Usage Classification: <b>INFORMATION</b>
Sheet Number:	Revision Number: R003	Page: 4 of 136

Title:

**REFERENCE LOW- AND INTERMEDIATE-LEVEL WASTE INVENTORY FOR THE DEEP GEOLOGIC REPOSITORY**

**List of Tables and Figures**

	Page
<b>Tables</b>	
Table 2.1: Scenario B Operational Low- and Intermediate-Level Waste Forecast Summary by Waste Type .....	12
Table 2.2: Low-Level Waste Categories .....	13
Table 2.3: Intermediate-Level Waste Categories.....	13
Table 2.4: Estimated Operational Low-Level Waste Radionuclide Inventory at 2018 .....	15
Table 2.5: Estimated Operational Low-Level Waste Radionuclide Inventory at 2062 .....	17
Table 2.6: Estimated Operational Intermediate-Level Waste Radionuclide Inventory at 2018..	19
Table 2.7: Estimated Operational Intermediate-Level Waste Radionuclide Inventory at 2062..	21
Table 2.8: Inventory of Non-Radioactive Components in Operational Low- and Intermediate-Level Waste .....	23
Table 2.9: Inventory of Low-Level Waste Container Materials .....	25
Table 2.10: Inventory of Intermediate-Level Waste Container Materials .....	26
Table 2.11: Inventory of Bulk Materials in Low-Level Waste .....	27
Table 2.12: Inventory of Bulk Materials in Intermediate-Level Waste .....	27
Table 3.1: Scenario B Reactor Refurbishment Waste Forecast Summary by Waste Type .....	28
Table 3.2: Estimated Reactor Refurbishment Radionuclide Inventory at 2018.....	30
Table 3.3: Estimated Reactor Refurbishment Radionuclide Inventory at 2062.....	32
Table 3.4: Elemental Inventory in Reactor Refurbishment Waste .....	34
Table 3.5: Inventory of Reactor Refurbishment Container Materials .....	35
Table 4.1: Scenario B Forecast Container Stored Volume .....	36
Table 4.2: Operational and Refurbishment Low- and Intermediate-Level Waste Package Inventory for Deep Geologic Repository .....	39
Table 4.3: Summary of Waste Volume Fraction Handled by Waste Type and Dose Rate (As-received at Western Waste Management Facility) .....	42
Table 4.4: Resin Liner Dose Rates “As Received” and After Decay .....	43
Table B.1: Summary of Specific Activities of Operational Low-Level Waste (As-received) .....	53
Table B.2: Summary of Specific Activities of Operation Intermediate-Level Waste (As-received) .....	55
Table B.3: Summary of Specific Activities of Reactor Refurbishment Wastes.....	57
Table C.1: Chemical Composition of Low- and Intermediate-Level Waste.....	59
Table C.2: Pressure Tube Elemental Composition .....	61
Table C.3: Calandria Tube Elemental Composition .....	62
Table C.4: Calandria Tube Inserts Elemental Composition .....	63
Table C.5: End Fittings Elemental Composition .....	64
Table C.6: Low- and Intermediate-Level Waste for the Deep Geological Repository .....	65
Table C.7: Physical Properties of Wastes.....	66
Table D.1: Uncertainties Associated with Gamma Activity Measurements.....	70
Table D.2: Uncertainties Associated with Scaling Factor Measurements.....	71
Table D.3: Uncertainties Associated with Retube and Core Component Wastes.....	72
Table D.4: Uncertainties Associated with Chemical Composition Measurements.....	72



**Report**

<b>OPG Proprietary</b>		
Document Number: <b>00216-REP-03902-00003</b>		Usage Classification: <b>INFORMATION</b>
Sheet Number: <b>N/A</b>	Revision Number: <b>R003</b>	Page: <b>5 of 136</b>

Title:

**REFERENCE LOW- AND INTERMEDIATE-LEVEL WASTE INVENTORY FOR THE DEEP GEOLOGIC REPOSITORY**

**Figures**

Figure 4.1: Annual Operational Low-Level Waste Production Forecast .....38  
Figure 4.2: Annual Operational Intermediate-Level Waste Production Forecast ..... 38  
Figure 4.3: Annual Reactor Refurbishment Waste Production Forecast ..... 38  
Figure 4.4: Decay Corrected Activity for Operational Low- and Intermediate-Level Waste ..... 41  
Figure 4.5: Decay Corrected Activity for Refurbishment Low- and Intermediate-Level Waste .. 41

**Report**

<b>OPG Proprietary</b>		
Document Number:	<b>00216-REP-03902-00003</b>	Usage Classification: <b>INFORMATION</b>
Sheet Number:	<b>N/A</b>	Revision Number: <b>R003</b>
		Page: <b>6 of 136</b>

Title:

**REFERENCE LOW- AND INTERMEDIATE-LEVEL WASTE INVENTORY FOR THE DEEP GEOLOGIC REPOSITORY**

**Revision Summary**

<b>Revision Number</b>	<b>Date</b>	<b>Comments</b>
R003	2010-12-17	<ul style="list-style-type: none"> <li>• Table 2.1 and 3.1 revised based on current received volumes and System Plan waste volume forecasts.</li> <li>• Updated Tables B.1, B.2 and B.3 with new specific activity information. Short-lived species added where they account for a significant fraction of the radioactivity.</li> <li>• Updated Table C.1 with new chemical composition data for bottom ash (new), baghouse ash (new), non-processible waste, heat exchangers, low level resin, and filters.</li> <li>• Forecast radionuclide inventories and material inventories recalculated based on updated waste volume forecasts and new specific activity data.</li> <li>• Data for LL Resin and ALW Resin combined under LL Resin waste type.</li> <li>• Table 2.9 updated to include new estimates for heat exchanger tube and shell weights and surface areas.</li> <li>• Table 2.10 modified to reflect current assumptions for handling of tile-hole-equivalent wastes</li> <li>• Table 2.11 modified to provide more complete description of composition.</li> <li>• Table 4.2 modified to reflect current assumptions for handling of tile-hole-equivalent wastes</li> <li>• Resin weights revised to account for bound water.</li> <li>• Information on waste retrieval at WWMF has been removed from this Reference Inventory report.</li> <li>• Various revisions and clarifications to the text and tables.</li> <li>• Container datasheets updated for current waste volume forecasts; some descriptions clarified or revised.</li> </ul>

## Report

OPG Proprietary		
Document Number:	00216-REP-03902-00003	Usage Classification: <b>INFORMATION</b>
Sheet Number:	Revision Number: <b>R003</b>	Page: <b>7 of 136</b>

Title:

## REFERENCE LOW- AND INTERMEDIATE-LEVEL WASTE INVENTORY FOR THE DEEP GEOLOGIC REPOSITORY

### Executive Summary

Ontario Power Generation is proposing to build a Deep Geologic Repository (DGR) for Low- and Intermediate-Level radioactive Waste (L&ILW). The purpose of this report is to describe the reference waste package inventory and waste characteristics for emplacement in the DGR, taking into consideration the current and potential future waste, including reactor retube and steam generator refurbishment waste.

The waste forecasts provided in this report are based on "Scenario B" defined in Nuclear Waste Management Division's System Plan, which considers refurbishment of all reactor units (except Pickering A) with operation for a further nominal 30 calendar years after refurbishment. It includes the effects of current nuclear unit layups, re-start dates, and end-of-life dates.

The projected total emplaced volume will be about 200,000 m<sup>3</sup> of operational L&ILW and refurbishment L&ILW, based on approximately 170,000 m<sup>3</sup> of stored volume. The corresponding total number of containers to be handled would be about 53,000. About 84% of the emplaced volume is low-level waste.

The reference planning assumption is that L&ILW will be retrieved from various storage structures at the Western Waste Management Facility (WWMF) and transferred to the DGR for emplacement following facility in-service. In this concept, no extra processing/packaging will be required with the exception of shielding of most of the ILW and overpacking of a small portion of the LLW. L&ILW at the nuclear generating stations will be shipped to the WWMF for processing, if required, and then directly to the DGR, except as required for staging DGR campaigns. It is also assumed that the future operational L&ILW will be shipped in containers similar to those currently used to store the L&ILW.

Ash containers, low level resin boxes, ALW sludge boxes, and 10% of drum racks containing drummed non-processible waste are expected to be packaged in LLW container overpacks. Disposable concrete shields will be used for most of the inventory of ILW resins, filters, IX columns, and core components. Large component wastes such as steam generators and heat exchangers are assumed to be size reduced to pieces that meet physical constraints and/or weight limits of the repository material handling systems.

The total operational and refurbishment L&ILW radionuclide inventory is estimated to be 17,000 TBq at repository closure (assumed here to be 2062), attributed mostly to H-3, C-14, Co-60, Nb-94 and Ni-63.

## Report

OPG Proprietary		
Document Number:	00216-REP-03902-00003	Usage Classification: <b>INFORMATION</b>
Sheet Number:	Revision Number: <b>R003</b>	Page: <b>8 of 136</b>

Title:

# REFERENCE LOW- AND INTERMEDIATE-LEVEL WASTE INVENTORY FOR THE DEEP GEOLOGIC REPOSITORY

## 1.0 INTRODUCTION

### 1.1 Purpose

Ontario Power Generation (OPG) is proposing to build a Deep Geologic Repository (DGR) for Low- and Intermediate-Level radioactive Waste (L&ILW) near its Western Waste Management Facility (WWMF) on the Bruce nuclear site. The purpose of this report is to define and describe the reference waste package inventory and reference waste characteristics for emplacement in the DGR, taking into consideration the current inventory and potential future waste arisings, including reactor retube and steam generator refurbishment waste.

### 1.2 Background

OPG's reference planning assumption is that L&ILW from the operation and maintenance of its nuclear power stations will be sent to the DGR for disposal.

L&ILW will be retrieved from various waste structures at the WWMF and transferred to the DGR, once it is placed into service. No extra processing/packaging is required, with the exception of shielding for most of the ILW and overpacking for a small portion of the LLW. L&ILW at the nuclear generating stations will be shipped to the WWMF for processing, if required, and then directly to the DGR, generally bypassing storage. (Some storage may be used at the WWMF to stage wastes for DGR campaigns.) In order to estimate the total volume for disposal in the DGR, it is also assumed that the future operational L&ILW will be shipped in containers similar to those currently used to store the L&ILW.

This report describes the reference inventory of waste packages to be placed in the DGR and their waste characteristics. Information on existing waste generation rates and package characteristics has been compiled from a number of sources and used to project the future inventory of wastes that will be generated during the period up to the shutdown of the last Darlington unit.

The L&ILW inventory projections and repository emplacement periods are based on "Scenario B" (see Appendix A) of Nuclear Waste Management Division's System Plan, which assumes refurbishment of all reactor units (except Pickering A) at or near the end of their initial life, with operation for a further 30 years after refurbishment. This is a conservative scenario for generation of waste.

The L&ILW inventory consists of operational waste and reactor refurbishment wastes. The operational L&ILW inventory includes bulk incinerable, compactable, and non-processible wastes, bulk low-level ion-exchange resins from station auxiliary systems, Active Liquid Waste Treatment System (ALW) resins and sludges, bulk low-level resins from historical CANDECON, miscellaneous large objects such as heat exchangers, intermediate-level resins, disposable IX columns, irradiated core components, filters and filter elements, and miscellaneous ILW resulting from the routine maintenance of nuclear stations. Reactor refurbishment waste is comprised of

## Report

OPG Proprietary		
Document Number:	00216-REP-03902-00003	Usage Classification: <b>INFORMATION</b>
Sheet Number:	Revision Number: <b>R003</b>	Page: <b>9 of 136</b>

Title:

### **REFERENCE LOW- AND INTERMEDIATE-LEVEL WASTE INVENTORY FOR THE DEEP GEOLOGIC REPOSITORY**

large scale retube waste (pressure tubes, calandria tubes and/or end fittings) and/or steam generators replaced during refurbishment.

### **1.3 Objectives and Scope**

The major objectives of this report are to:

- (a) Describe the physical, chemical, and radiological characteristics of operational L&ILW and reactor refurbishment waste currently in storage and projected for the future.
- (b) Document the reference inventory of operational L&ILW and refurbishment waste packages (numbers and types) that will be sent to the DGR, including assumptions used to calculate the inventory.
- (c) Provide information on the containers currently used to store operational L&ILW and that will likely be used for emplacement.

Decommissioning wastes are not included in this report.

Waste projections from any proposed new-build reactors in Ontario are not included in this report.

This report will be revised as additional or more up-to-date waste inventory and waste package data becomes available.

OPG Proprietary		
Document Number:	00216-REP-03902-00003	Usage Classification: <b>INFORMATION</b>
Sheet Number:	Revision Number: R003	Page: 10 of 136

Title:

## REFERENCE LOW- AND INTERMEDIATE-LEVEL WASTE INVENTORY FOR THE DEEP GEOLOGIC REPOSITORY

### 2.0 PROJECTED OPERATIONAL LOW- AND INTERMEDIATE-LEVEL WASTE INVENTORY AND CHARACTERISTICS

#### 2.1 Waste Volumes and Package Inventory

The amount of waste and number of packages projected over the life of Ontario's nuclear program is calculated based on the existing inventory [Anderson et al, 2005] and assumed future production and processing scenarios. Table 2.1 summarizes the forecast operational L&ILW inventory by waste type, including reference assumptions for disposal based on "Scenario B" (see Appendix A). "Scenario B" assumes refurbishment of all reactor units (except Pickering A) at or near the end of their initial life, with operation for a further 30 years after refurbishment. This is conservative scenario for generation of waste. Tables 2.2 and 2.3 describe the various L&ILW types listed in Table 2.1.

The major other sources of uncertainty in the projections of L&ILW are summarized as follows:

- (i) Impacts on waste volume stored if different waste processing methods or packages are used in future.
- (ii) Unplanned-for wastes, such as unforeseen major maintenance activities.
- (iii) Long term effects of changes to station waste management practices (e.g., the effectiveness of various waste minimization programs).

#### 2.2 Radionuclide Inventory

Radionuclide activity concentrations in L&ILW as-received at WWMF are presented in Appendix B. They are a result of either fixed (inherent to the material) or surface contamination. The data are based on direct measurements, scaling factors, used fuel ratios, and neutron activation calculations.

Scaling factors were adopted to calculate the concentrations of difficult-to-measure radionuclides such as pure beta emitters, which cannot be measured by non-intrusive methods in waste packages. The scaling factor methodology is widely used internationally [ISO 2007, IAEA 2009]. The scaling factors were generally based on actual measurements of difficult-to-measure radionuclides obtained from gamma spectrometry of waste packages and/or samples of waste [Husain, 2005a, 2005b]. Scaling factors were also developed from predicted data from fission product release and activation models (i.e., Cl-36, Se-79, Tc-99, and I-129) [Lewis and Husain, 2003, Lewis et al. 2003]. Tritium estimates for bulk LLW are based on C-14/H-3 ratios derived from incinerator emissions data. Scaling factors for other nuclides are calculated from their relative abundance in used fuel [Tait et al, 2000]. The activity data for direct measurements and scaling factors are best estimates based on log-mean averages.

## Report

OPG Proprietary		
Document Number:	00216-REP-03902-00003	Usage Classification: <b>INFORMATION</b>
Sheet Number:	Revision Number: <b>R003</b>	Page: <b>11 of 136</b>

Title:

### **REFERENCE LOW- AND INTERMEDIATE-LEVEL WASTE INVENTORY FOR THE DEEP GEOLOGIC REPOSITORY**

Tables 2.4 - 2.7 summarize the estimated total decay corrected radionuclide inventory of projected operational L&ILW at 2 future dates:

- (1) 2018, the earliest assumed in-service date of the repository, and
- (2) 2062, the assumed repository closure date (based on 10 years after the 2052 forecast shutdown date of the last reactor unit).

They are based on the operational L&ILW characteristics given in Appendix B, and the projected operational L&ILW volumes calculated for those years. The 2018 inventory assumes all the then-current WWMF inventory is rapidly moved into the DGR.

Report

<b>OPG Proprietary</b>		
Document Number: <b>00216-REP-03902-00003</b>	Usage Classification: <b>INFORMATION</b>	
Sheet Number: <b>N/A</b>	Revision Number: <b>R003</b>	Page: <b>12 of 136</b>

Title:  
**REFERENCE LOW- AND INTERMEDIATE-LEVEL WASTE INVENTORY FOR THE DEEP GEOLOGIC REPOSITORY**

**Table 2.1: Scenario B Operational Low- and Intermediate-Level Waste Forecast Summary by Waste Type**

Waste Type	Net Volume (m <sup>3</sup> )	Number of Containers	Emplaced Volume (m <sup>3</sup> )	Reference Assumptions for DGR
Bottom Ash (Old)	806	250	2,125	Overpack 100% in DGR ready LLW container overpack.
Baghouse Ash (Old)	55	46	391	Overpack 100% in DGR ready LLW container overpack.
Bottom Ash (New)	1,227	632	5,372	Overpack 100% in DGR ready LLW container overpack.
Baghouse Ash (New)	309	172	1,462	Overpack 100% in DGR ready LLW container overpack.
Compact Bales	2,268	1,383	4,702	Assume 25% are incinerated, and remainder overpacked in a container to be determined.
Box Compacted	14,110	6,135	17,177	Transfer containers to DGR as-is.
Non-processible*	53,515	22,591	70,115	Transfer containers to DGR as-is.
Feeder Pipes	3,198	1,599	3,677	Transfer containers (non-pro high capacity containers) to DGR as-is.
Non-pro Other <sup>^</sup>	3,279	164	3,279	Assume 25% of HXs are cut into 2 segments and seal plates are welded similar to SGs; transfer remainder to DGR as-is. ETHs will be transferred to DGR as-is.
Non-processible Drummed	9,408	7,840	25,532	Overpack 10% of drum racks in DGR ready LLW container overpack; transfer remainder to DGR as-is. Transfer drum bins to DGR as-is.
LL Resin/ALW Resin	3,393	2,165	6,307	Overpack 100% of LL resin boxes in DGR ready LLW container overpack. Resin pallet tanks (used for both LL Resin and ALW Resin) to be overpacked in container to be determined and transferred to DGR.
ALW Sludge	3,569	1,709	14,527	Overpack 100% in DGR ready LLW container overpack.
Moderator IX Resin	1,929	430	4,779	Resin liners will be transferred in shielded or unshielded packages depending on their dose rate. The number of containers was estimated here assuming 28% of resin liners (including 400 in SS overpacks) will be emplaced without a shield, 53% will be placed into a standard cylindrical concrete shield, and 19% will be placed in thicker concrete shields.
PHT IX Resin	1,348	301	3,340	Assumptions same as moderator IX resin.
CANDECON Resin	2,257	503	5,592	Assumptions same as moderator IX resin.
Miscellaneous IX Resin <sup>+</sup>	1,808	403	4,480	Assumptions same as moderator IX resin.
IX Columns <sup>#</sup>	544	4,453	9,453	The contents of IC-18 T-H-E liners and IC-2 liners will be retrieved into a new waste package (ATHEL with similar dimensions to a resin liner), placed within a sacrificial concrete shield. Tile hole liners and ILW shields will be transferred to DGR as-is.
Irradiated Core Components <sup>#</sup>	27			
Filters and Filter Elements <sup>#</sup>	1,344			
<b>Totals</b>	<b>104,394</b>	<b>50,776</b>	<b>182,310</b>	

**Note:** Old and new bottom and baghouse ash refer to ash collected from old and new incinerators respectively.

\* Includes miscellaneous LLW and miscellaneous trench waste packed in NPB47 and shield plugs.

<sup>^</sup> Includes heat exchangers and encapsulated tile holes.

<sup>+</sup> Comprised of station auxiliary system resins.

<sup>#</sup> Stored in IC-18 T-H-E liners, IC-2 liners, tile hole liners, and ILW shields.



**Report**

<b>OPG Proprietary</b>		
Document Number:	<b>00216-REP-03902-00003</b>	Usage Classification:
		<b>INFORMATION</b>
Sheet Number:	Revision Number:	Page:
<b>N/A</b>	<b>R003</b>	<b>13 of 136</b>

Title:

**REFERENCE LOW- AND INTERMEDIATE-LEVEL WASTE INVENTORY FOR THE DEEP GEOLOGIC REPOSITORY**

**Table 2.2: Low-Level Waste Categories**

<b>Waste Category</b>	<b>Description</b>
Bottom ash	Heterogeneous ash and clinker from waste incineration.
Baghouse ash	Fine homogeneous ash from waste incineration.
Compact Bales	Generally compactable solid LLW; for example empty waste drums, rubber hoses, rubber area floor matting, light gauge metals, welding rods, plastic conduit, fire blankets and fire retardant material, metal cans, insulation, ventilation filters, air hoses, metal mop buckets and presses, electric cable (<1/4" diameter), lathe turnings, metal filings, glass, plastic suits (Mark III/IV), rubbers, Vicraft hoods, rubber gloves.
Box Compacted	Same as compact bales.
Non-Processible	Solid LLW that is non-compactable or has contact dose greater than 2 mSv/h; for example, heavy gauge metal (e.g., beams, IX vessels, angle iron, plate metal), concrete and cement blocks, metal components (e.g., pipe, scaffolding pipes, metal planks, motors, flanges, valves), wire cables and slings, electric cables (>1/4" diameter), Comfo respirator filters, tools, paper, plastic, absorbent products, laboratory sealed sources, feeder pipes.
Non-Processible Drummed	Generally small, granular or solidified LLW; for example, floor sweepings, Dust Bane, Stay Dry, metal filings, glassware, light bulbs, bitumenized low-level waste, etc.
Non-Processible Other	Large and irregularly shaped objects such as heat exchangers, encapsulated tile holes, feeder pipes, shield plugs, and other miscellaneous large objects (e.g., fume hoods, glove boxes, processing equipment).
LL Resin	Spent IX resin arising from light water auxiliary systems.
ALW Resin	Spent IX resin arising from Active Liquid Waste Treatment Systems.
ALW Sludge	Sludge from a two-stage Active Liquid Waste Treatment System at Bruce A.

**Table 2.3: Intermediate-Level Waste Categories**

<b>Waste Category</b>	<b>Description</b>
Moderator resin	Spent IX resin arising from moderator purification systems.
PHT resin	Spent IX resin arising from PHT purification systems.
IX Columns	Spent IX resin arising from Pickering PHT purification system.
Misc. resin	Spent IX resin arising from station auxiliary systems (e.g., heavy water upgraders).
CANDECON Resin	Spent IX resin from the chemical decontamination process for nuclear heat transport systems.
Irradiated core components	Includes flux detectors and liquid zone control rods.
Filters and filter elements	Filters and filter elements from various station process systems.

## Report

OPG Proprietary		
Document Number:	00216-REP-03902-00003	Usage Classification: <b>INFORMATION</b>
Sheet Number:	Revision Number: <b>R003</b>	Page: <b>14 of 136</b>

Title:

### **REFERENCE LOW- AND INTERMEDIATE-LEVEL WASTE INVENTORY FOR THE DEEP GEOLOGIC REPOSITORY**

For simplicity of display, short-lived radionuclides (half-life less than 1-year) are generally not shown in the body of the table unless they are significant. Their inventories, however, are included in the totals at the bottom of each column.

The results for the assumed repository closure date of 2062 indicate that the total operational L&ILW radioactivity will be dominated at closure by H-3, C-14 and Cs-137.

The uncertainties associated with the radionuclide inventories are presented in Appendix D.

### **2.3 Chemical Inventory**

The inventories of non-radioactive components in L&ILW at 2052 (shutdown date of last reactor unit) are summarized in Table 2.8. As these are stable elements, their inventory will not change prior to repository closure. The data are based on L&ILW chemical properties presented in Appendix C, and net volumes for each of the individual waste streams documented in Table 2.1. The uncertainties associated with the chemical compositions are presented in Appendix D.

### **2.4 Bulk Material Inventory**

The physical characteristics of L&ILW and the containers in which they are stored are important considerations for waste handling and emplacement. They are also important parameters in evaluating the long-term degradation of the L&ILW.

The inventory of L&ILW container materials at 2052, in terms of mass and total surface area is summarized in Tables 2.9 and 2.10. The inventory is based on the weight of steel and concrete in each container, and container numbers listed in Table 2.1. The surface areas are calculated based on container dimensions provided in Appendix E, and container numbers listed in Table 2.1.

The estimated inventories of ash, cellulose (including cloth), plastics (including rubber), bitumen, resin, steel, and concrete in L&ILW at 2052 are presented in Tables 2.11 and 2.12. They are based on characterisation data and estimated bulk densities of various L&ILW types documented in Appendix C, and net volumes listed in Table 2.1.

The total inventory of steel in operational L&ILW package materials, including the iron in concrete shield rebar is estimated to be approximately  $2.7 \times 10^7$  kg. The estimated weight of concrete shielding that will be required is  $3.5 \times 10^7$  kg based on the current assumptions for ILW shielding design.

The total estimated inventory of steel in operational L&ILW is estimated to be  $6.9 \times 10^6$  kg. The total organic component, consisting of cellulose, plastic materials, bitumen, and (dry) ion exchange resins, is estimated to be  $2.2 \times 10^7$  kg.

Report

<b>OPG Proprietary</b>		
Document Number: <b>00216-REP-03902-00003</b>		Usage Classification: <b>INFORMATION</b>
Sheet Number: <b>N/A</b>	Revision Number: <b>R003</b>	Page: <b>15 of 136</b>

Title:  
**REFERENCE LOW- AND INTERMEDIATE-LEVEL WASTE INVENTORY FOR THE DEEP GEOLOGIC REPOSITORY**

Table 2.4: Estimated Operational Low-Level Waste Radionuclide Inventory at 2018

		Decay Corrected Radionuclide Inventory (Bq)										
		Bottom Ash	Baghouse Ash	Compact Bales	Box Compacted	Non-pro	Feeder Pipes	Non-pro Other	Non-pro Drummed	LL/ALW Resin	ALW Sludge	Total
Net Volume (m <sup>3</sup> )		1,352	291	2,268	10,328	36,202	2,101	3,071	6,760	1,384	1,722	65,479
Nuclide	T-1/2 (yrs)											
Ag-108m	1.3E+02	6.2E+05	6.6E+05	6.3E+05	3.7E+06	1.5E+07	2.7E+06	1.3E+06	2.9E+06	1.4E+05	1.3E+05	2.8E+07
Am-241	4.3E+02	1.1E+09	5.2E+07	2.2E+08	1.8E+09	1.6E+10	2.0E+10	6.5E+07	1.5E+05	1.9E+08	9.5E+06	3.9E+10
Am-242m	1.5E+02						3.4E+07					3.4E+07
Am-243	7.4E+03	1.1E+06	4.6E+04	3.4E+05	2.5E+06	1.2E+06	3.9E+07	8.5E+04	2.5E+02	2.6E+04	1.4E+04	4.4E+07
Ba-133	1.1E+01					2.4E+09						2.4E+09
C-14	5.7E+03	2.5E+10	4.6E+08	1.3E+10	6.9E+10	6.0E+10	6.9E+11	3.3E+09	1.0E+11	8.7E+09	3.8E+09	9.7E+11
Cf-252	2.6E+00					3.4E+07						3.4E+07
Cl-36	3.0E+05	4.2E+05	4.8E+04	1.5E+05	8.3E+05	1.4E+06	3.5E+08	6.1E+04	3.0E+05	1.5E+04	9.1E+03	3.5E+08
Cm-244	1.8E+01	1.2E+08	3.4E+06	3.4E+07	5.3E+08	4.1E+08	7.4E+09	1.2E+07	1.2E+04	4.0E+06	2.4E+06	8.5E+09
Co-60	5.3E+00	6.0E+10	7.7E+08	3.0E+09	2.0E+11	5.3E+11	2.3E+13	1.8E+10	6.0E+10	6.1E+09	3.2E+09	2.4E+13
Cs-134	2.1E+00	8.7E+07	6.1E+07	6.5E+05	7.0E+09	1.1E+09	4.2E+10	1.3E+08	1.7E+09	2.1E+07	1.2E+09	5.3E+10
Cs-135	2.3E+06	6.9E+04	6.9E+04	7.3E+04	3.9E+05	1.7E+06	2.7E+05	1.4E+05	3.1E+05	1.4E+04	1.3E+04	3.0E+06
Cs-137+Ba-137m	3.0E+01	7.8E+10	8.4E+10	7.0E+10	5.6E+11	1.8E+13	5.2E+11	2.0E+11	4.0E+11	2.2E+10	2.0E+10	2.0E+13
Eu-152	1.3E+01	1.8E+06	0.0E+00			3.9E+06			1.3E+08			1.4E+08
Eu-154	8.8E+00	5.6E+08	8.3E+07	4.0E+08	8.9E+09	2.7E+09	1.0E+11		1.0E+08			1.1E+11
Eu-155	5.0E+00	2.1E+07		1.4E+07	1.1E+09							1.1E+09
Fe-55	2.7E+00	1.8E+12	1.3E+09	2.0E+08	2.7E+10	6.8E+11	5.4E+13	5.0E+10	6.3E+10	1.8E+10	6.1E+09	5.7E+13
H-3	1.2E+01	1.2E+10		3.9E+13	9.3E+14	4.4E+14		2.8E+13	1.7E+15	1.1E+11	3.1E+12	3.1E+15
I-129	1.6E+07	3.6E+03	1.1E+04	2.7E+02	4.1E+04	5.2E+05	7.7E+04	5.2E+02	1.0E+05	4.8E+03	4.6E+01	7.6E+05
Nb-94	2.0E+04	2.7E+09	3.5E+06	1.9E+09	1.0E+10	1.7E+07			7.4E+08		7.2E+07	1.5E+10
Ni-59	7.5E+04	2.0E+08	4.7E+06	1.0E+07	5.8E+07	2.6E+08	8.2E+08	1.6E+07	3.8E+07	2.5E+06	1.5E+06	1.4E+09
Ni-63	9.6E+01	2.4E+10	5.8E+08	1.1E+09	7.3E+09	6.1E+10	1.1E+11	2.1E+09	4.7E+09	3.3E+08	2.1E+08	2.1E+11
Np-237	2.1E+06	5.2E+04	2.3E+03	1.6E+04	1.2E+05	5.7E+04	1.8E+06	4.2E+03	1.2E+01	1.3E+03	6.9E+02	2.1E+06
Pb-210	2.2E+01					5.7E+10						5.7E+10
Pu-238	8.8E+01	3.0E+08	1.1E+07	4.1E+07	3.5E+08	4.6E+08	6.4E+09	1.2E+07	2.2E+04	4.0E+06	2.1E+06	7.6E+09
Pu-239	2.4E+04	3.4E+08	1.5E+07	1.1E+08	8.0E+08	9.3E+08	1.2E+10	2.7E+07	8.0E+04	8.4E+06	4.5E+06	1.4E+10

**Report**

<b>OPG Proprietary</b>		
Document Number:	<b>00216-REP-03902-00003</b>	Usage Classification:
		<b>INFORMATION</b>
Sheet Number:	Revision Number:	Page:
<b>N/A</b>	<b>R003</b>	<b>16 of 136</b>

**Title: REFERENCE LOW- AND INTERMEDIATE-LEVEL WASTE INVENTORY FOR THE DEEP GEOLOGIC REPOSITORY**

		Decay Corrected Radionuclide Inventory (Bq)										
		Bottom Ash	Baghouse Ash	Compact Bales	Box Compacted	Non-pro	Feeder Pipes	Non-pro Other	Non-pro Drummed	LL/ALW Resin	ALW Sludge	Total
<b>Net Volume (m<sup>3</sup>)</b>		<b>1,352</b>	<b>291</b>	<b>2,268</b>	<b>10,328</b>	<b>36,202</b>	<b>2,101</b>	<b>3,071</b>	<b>6,760</b>	<b>1,384</b>	<b>1,722</b>	<b>65,479</b>
Nuclide	T-1/2 (yrs)											
Pu-240	6.5E+03	5.0E+08	2.1E+07	1.5E+08	1.1E+09	1.4E+09	1.7E+10	3.9E+07	1.1E+05	1.2E+07	6.4E+06	2.0E+10
Pu-241	1.4E+01	1.2E+10	3.0E+08	9.5E+08	1.8E+10	1.7E+10	2.4E+11	7.4E+08	1.6E+06	2.4E+08	1.3E+08	2.9E+11
Pu-242	3.8E+05	5.1E+05	2.1E+04	1.6E+05	1.1E+06	5.3E+05	1.8E+07	3.9E+04	1.1E+02	1.2E+04	6.5E+03	2.0E+07
Ra-226	1.6E+03					2.8E+09						2.8E+09
Ru-106	1.0E+00	1.2E+08	1.2E+06	1.4E+03	3.9E+10	2.1E+09	1.1E+12	2.3E+08	2.8E+08			1.1E+12
Sb-125	2.8E+00	1.6E+09	1.6E+08	1.6E+07	1.8E+10	4.1E+09	1.4E+11	4.4E+08	1.0E+09		1.0E+09	1.7E+11
Se-79	3.8E+05	2.4E+03	2.5E+03	2.5E+03	1.4E+04	5.7E+04	9.2E+05	4.9E+03	1.1E+04	5.0E+02	4.6E+02	1.0E+06
Sm-151	9.0E+01	1.9E+05	2.0E+05	2.0E+05	1.2E+06	5.0E+06	9.1E+05	4.3E+05	9.4E+05	4.5E+04	4.1E+04	9.2E+06
Sn-126	2.1E+05	3.6E+05	3.7E+05	3.9E+05	2.1E+06	8.6E+06	1.4E+06	7.3E+05	1.6E+06	7.6E+04	6.9E+04	1.6E+07
Sr-90+Y-90	2.9E+01	3.0E+10	8.0E+08	2.6E+09	2.2E+10	5.0E+11	4.8E+12	2.4E+09	7.4E+10	1.5E+09	5.2E+08	5.4E+12
Tc-99	2.1E+05	4.9E+04	1.2E+03	3.2E+04	1.7E+05	2.1E+05	3.4E+07	1.2E+04	6.0E+04	3.0E+03	1.9E+03	3.4E+07
U-232	7.2E+01						3.2E+06					3.2E+06
U-233	1.6E+05						4.3E+06					4.3E+06
U-234	2.5E+05	5.6E+05	2.3E+04	1.7E+05	1.3E+06	6.0E+05	2.0E+07	4.2E+04	1.3E+02	1.4E+04	7.2E+03	2.3E+07
U-235	7.0E+08	9.2E+03	3.8E+02	2.9E+03	2.0E+04	1.0E+04	3.2E+05	7.3E+02	2.1E+00	2.2E+02	1.2E+02	3.6E+05
U-236	2.3E+07	1.0E+05	4.4E+03	3.2E+04	2.3E+05	1.1E+05	3.7E+06	8.2E+03	2.4E+01	2.5E+03	1.3E+03	4.2E+06
U-238	4.5E+09	6.9E+05	2.9E+04	2.2E+05	1.6E+06	2.8E+09	2.5E+07	5.5E+04	1.6E+02	1.7E+04	9.0E+03	2.8E+09
Zr-93	1.5E+06	2.1E+04	1.9E+02	7.9E+03	4.2E+04	7.9E+04	9.2E+05	6.7E+03	4.9E+03		6.5E+02	1.1E+06
<b>Totals as listed</b>		<b>2.0E+12</b>	<b>8.9E+10</b>	<b>3.9E+13</b>	<b>9.3E+14</b>	<b>4.6E+14</b>	<b>8.5E+13</b>	<b>2.8E+13</b>	<b>1.7E+15</b>	<b>1.7E+11</b>	<b>3.1E+12</b>	<b>3.2E+15</b>
<b>Totals with other short lived</b>		<b>2.1E+12</b>	<b>8.9E+10</b>	<b>3.9E+13</b>	<b>9.3E+14</b>	<b>4.6E+14</b>	<b>9.1E+13</b>	<b>2.8E+13</b>	<b>1.7E+15</b>	<b>1.7E+11</b>	<b>3.1E+12</b>	<b>3.3E+15</b>

**Note:** Nuclides with half lives greater than 1 yr are shown, plus short-lived progeny.

Report

<b>OPG Proprietary</b>		
Document Number:	<b>00216-REP-03902-00003</b>	Usage Classification: <b>INFORMATION</b>
Sheet Number:	<b>N/A</b>	Revision Number: <b>R003</b>
		Page: <b>17 of 136</b>

Title:  
**REFERENCE LOW- AND INTERMEDIATE-LEVEL WASTE INVENTORY FOR THE DEEP GEOLOGIC REPOSITORY**

**Table 2.5: Estimated Operational Low-Level Waste Radionuclide Inventory at 2062**

		Decay Corrected Radionuclide Inventory (Bq)										
		Bottom Ash	Baghouse Ash	Compact Bales	Box Compacted	Non-pro	Feeder Pipes	Non-pro Other	Non-pro Drummed	LL/ALW Resin	ALW Sludge	Total
Net Volume (m <sup>3</sup> )		2,033	364	2,268	14,110	53,515	3,198	3,279	9,408	3,393	3,569	95,137
Nuclide	T-1/2 (yrs)											
Ag-108m	1.3E+02	6.6E+05	5.4E+05	5.0E+05	4.1E+06	1.9E+07	3.2E+06	1.2E+06	3.2E+06	3.0E+05	2.2E+05	3.3E+07
Am-241	4.3E+02	3.0E+09	5.0E+07	2.0E+08	2.7E+09	2.0E+10	2.9E+10	6.8E+07	2.0E+05	4.5E+08	1.9E+07	5.5E+10
Am-242m	1.5E+02						5.1E+07					5.1E+07
Am-243	7.4E+03	2.7E+06	4.8E+04	3.4E+05	3.9E+06	1.7E+06	5.9E+07	9.5E+04	3.4E+02	6.4E+04	3.0E+04	6.8E+07
Ba-133	1.1E+01					7.1E+08						7.1E+08
C-14	5.7E+03	6.4E+10	4.6E+08	1.3E+10	9.4E+10	7.4E+10	1.0E+12	3.7E+09	1.4E+11	2.1E+10	7.8E+09	1.4E+12
Cf-252	2.6E+00					1.2E+06						1.2E+06
Cl-36	3.0E+05	5.9E+05	4.8E+04	1.5E+05	1.1E+06	2.0E+06	5.4E+08	6.8E+04	4.0E+05	3.7E+04	1.9E+04	5.4E+08
Cm-244	1.8E+01	1.1E+08	8.1E+05	6.3E+06	2.5E+08	1.2E+08	2.2E+09	2.9E+06	4.9E+03	3.5E+06	1.7E+06	2.7E+09
Co-60	5.3E+00	6.0E+09	7.4E+06	9.0E+06	1.0E+10	1.4E+10	1.4E+11	1.1E+08	3.3E+09	9.4E+08	4.5E+08	1.7E+11
Cs-134	2.1E+00	4.5E+05	5.9E+04	2.4E-01	2.6E+07	5.9E+06	5.9E+04	5.5E+02	4.5E+06	2.9E+05	1.9E+07	5.6E+07
Cs-135	2.3E+06	8.9E+04	7.2E+04	7.3E+04	5.3E+05	2.5E+06	4.1E+05	1.6E+05	4.2E+05	3.4E+04	2.7E+04	4.3E+06
Cs-137+ Ba-137m	3.0E+01	4.8E+10	3.2E+10	2.6E+10	3.4E+11	1.2E+13	3.0E+11	8.6E+10	2.4E+11	2.8E+10	2.2E+10	1.3E+13
Eu-152	1.3E+01	1.8E+05				7.1E+05			3.6E+07			3.7E+07
Eu-154	8.8E+00	9.4E+07	2.6E+06	1.2E+07	1.2E+09	8.3E+07	5.7E+09	0.0E+00	1.5E+07			7.1E+09
Eu-155	5.0E+00	4.4E+04		2.9E+04	5.1E+07							5.1E+07
Fe-55	2.7E+00	2.9E+10	3.1E+06	2.5E+03	2.4E+07	6.2E+09	1.9E+09	3.4E+06	5.0E+08	5.7E+08	2.1E+08	3.8E+10
H-3	1.2E+01	4.5E+09		3.3E+12	2.8E+14	1.4E+14		3.2E+12	4.2E+14	6.6E+10	1.5E+12	8.5E+14
I-129	1.6E+07	1.0E+04	1.1E+04	2.7E+02	8.8E+04	7.7E+05	1.2E+05	5.8E+02	1.4E+05	1.2E+04	9.6E+01	1.2E+06
Nb-94	2.0E+04	5.2E+09	7.2E+06	1.9E+09	1.4E+10	2.1E+07			1.0E+09		1.5E+08	2.2E+10
Ni-59	7.5E+04	2.6E+08	4.8E+06	1.0E+07	8.2E+07	3.9E+08	1.3E+09	1.8E+07	5.2E+07	6.1E+06	3.2E+06	2.1E+09
Ni-63	9.6E+01	2.5E+10	4.3E+08	8.3E+08	8.0E+09	6.7E+10	1.3E+11	1.7E+09	4.9E+09	6.7E+08	3.5E+08	2.4E+11
Np-237	2.1E+06	1.3E+05	2.4E+03	1.6E+04	1.9E+05	8.5E+04	2.8E+06	4.8E+03	1.6E+01	3.2E+03	1.4E+03	3.2E+06
Pb-210	2.2E+01					3.2E+10						3.2E+10

**Report**

<b>OPG Proprietary</b>		
Document Number: <b>00216-REP-03902-00003</b>		Usage Classification: <b>INFORMATION</b>
Sheet Number: <b>N/A</b>	Revision Number: <b>R003</b>	Page: <b>18 of 136</b>

**REFERENCE LOW- AND INTERMEDIATE-LEVEL WASTE INVENTORY FOR THE DEEP GEOLOGIC REPOSITORY**

		Decay Corrected Radionuclide Inventory (Bq)										
		Bottom Ash	Baghouse Ash	Compact Bales	Box Compacted	Non-pro	Feeder Pipes	Non-pro Other	Non-pro Drummed	LL/ALW Resin	ALW Sludge	Total
<b>Net Volume (m<sup>3</sup>)</b>		<b>2,033</b>	<b>364</b>	<b>2,268</b>	<b>14,110</b>	<b>53,515</b>	<b>3,198</b>	<b>3,279</b>	<b>9,408</b>	<b>3,393</b>	<b>3,569</b>	<b>95,137</b>
Nuclide	T-1/2 (yrs)											
Pu-238	8.8E+01	6.3E+08	8.2E+06	2.9E+07	4.2E+08	4.0E+08	7.0E+09	9.4E+06	2.2E+04	7.7E+06	3.4E+06	8.5E+09
Pu-239	2.4E+04	8.4E+08	1.5E+07	1.1E+08	1.3E+09	1.1E+09	1.9E+10	3.0E+07	1.1E+05	2.1E+07	9.3E+06	2.2E+10
Pu-240	6.5E+03	1.2E+09	2.2E+07	1.5E+08	1.8E+09	1.6E+09	2.5E+10	4.4E+07	1.5E+05	2.9E+07	1.3E+07	3.0E+10
Pu-241	1.4E+01	8.2E+09	4.3E+07	1.1E+08	6.4E+09	4.4E+09	4.8E+10	1.2E+08	4.8E+05	1.7E+08	7.5E+07	6.8E+10
Pu-242	3.8E+05	1.2E+06	2.2E+04	1.6E+05	1.8E+06	7.9E+05	2.8E+07	4.4E+04	1.5E+02	3.0E+04	1.4E+04	3.2E+07
Ra-226	1.6E+03					3.8E+09						3.8E+09
Ru-106	1.0E+00	1.0E+04	8.8E+01	1.1E-10	2.7E+06	2.4E+05	1.8E+00	5.0E-03	9.1E+03			3.0E+06
Sb-125	2.8E+00	2.7E+07	4.5E+05	2.7E+02	2.0E+08	5.6E+07	6.5E+06	3.8E+04	8.8E+06		3.9E+07	3.4E+08
Se-79	3.8E+05	3.1E+03	2.6E+03	2.5E+03	1.9E+04	8.6E+04	1.4E+06	5.4E+03	1.5E+04	1.2E+03	9.6E+02	1.5E+06
Sm-151	9.0E+01	1.9E+05	1.5E+05	1.4E+05	1.2E+06	5.8E+06	1.0E+06	3.5E+05	9.7E+05	8.8E+04	6.8E+04	1.0E+07
Sn-126	2.1E+05	4.7E+05	3.8E+05	3.9E+05	2.9E+06	1.3E+07	2.2E+06	8.1E+05	2.2E+06	1.9E+05	1.4E+05	2.3E+07
Sr-90+Y-90	2.9E+01	2.0E+10	3.0E+08	9.2E+08	1.4E+10	2.8E+11	2.6E+12	1.0E+09	4.6E+10	1.9E+09	5.4E+08	3.0E+12
Tc-99	2.1E+05	8.3E+04	1.2E+03	3.2E+04	2.3E+05	3.1E+05	5.1E+07	1.3E+04	8.2E+04	7.5E+03	3.9E+03	5.2E+07
U-232	7.2E+01						4.9E+06					4.9E+06
U-233	1.6E+05						6.6E+06					6.6E+06
U-234	2.5E+05	1.4E+06	2.4E+04	1.7E+05	2.0E+06	9.0E+05	3.1E+07	4.7E+04	1.7E+02	3.4E+04	1.5E+04	3.6E+07
U-235	7.0E+08	2.2E+04	4.0E+02	2.9E+03	3.3E+04	1.5E+04	4.9E+05	8.1E+02	2.8E+00	5.4E+02	2.5E+02	5.6E+05
U-236	2.3E+07	2.5E+05	4.6E+03	3.2E+04	3.7E+05	1.7E+05	5.6E+06	9.2E+03	3.2E+01	6.1E+03	2.8E+03	6.4E+06
U-238	4.5E+09	1.7E+06	3.0E+04	2.2E+05	2.5E+06	4.2E+09	3.8E+07	6.1E+04	2.2E+02	4.1E+04	1.9E+04	4.2E+09
Zr-93	1.5E+06	4.0E+04	2.0E+02	7.9E+03	5.7E+04	1.2E+05	1.4E+06	7.5E+03	6.7E+03		1.4E+03	1.6E+06
<b>Totals as listed</b>		<b>2.2E+11</b>	<b>3.3E+10</b>	<b>3.3E+12</b>	<b>2.8E+14</b>	<b>1.5E+14</b>	<b>4.3E+12</b>	<b>3.3E+12</b>	<b>4.2E+14</b>	<b>1.2E+11</b>	<b>1.5E+12</b>	<b>8.7E+14</b>
<b>Totals with other short lived</b>		<b>2.2E+11</b>	<b>3.4E+10</b>	<b>3.4E+12</b>	<b>2.8E+14</b>	<b>1.5E+14</b>	<b>4.4E+12</b>	<b>3.3E+12</b>	<b>4.2E+14</b>	<b>1.2E+11</b>	<b>1.5E+12</b>	<b>8.7E+14</b>

**Note:** Nuclides with half lives greater than 1 yr are shown, plus short-lived progeny.

Report

OPG Proprietary		
Document Number:	00216-REP-03902-00003	Usage Classification: <b>INFORMATION</b>
Sheet Number:	N/A	Revision Number: R003
		Page: 19 of 136

Title:

**REFERENCE LOW- AND INTERMEDIATE-LEVEL WASTE INVENTORY FOR THE DEEP GEOLOGIC REPOSITORY**

Table 2.6: Estimated Operational Intermediate-Level Waste Radionuclide Inventory at 2018

		Decay Corrected Radionuclide Inventory (Bq)							
		Moderator IX Resin	PHT IX Resin	Misc. IX Resin	CAN-DECON Resin	IX Columns	Irradiated Core Comp.	Filters and Filter Elements	Total
Net Volume (m <sup>3</sup> )		1,174	802	1,097	1,427	299	23	606	5,428
Nuclide	T-1/2 (yrs)								
Ag-108m	1.3E+02		4.2E+08	1.4E+08	1.7E+07	1.5E+08		8.9E+05	7.3E+08
Am-241	4.3E+02		7.9E+07	3.0E+10	9.7E+10	2.9E+07		1.3E+10	1.4E+11
Am-243	7.4E+03		9.6E+05	3.7E+06	7.4E+07	3.6E+05		1.8E+07	9.8E+07
C-14	5.7E+03	3.2E+15	7.0E+13	1.6E+13	1.4E+11	2.6E+13	1.8E+12	7.1E+12	3.3E+15
Ce-141	8.9E-02	3.5E+10	7.0E+10	6.1E+13	1.2E+12	3.7E+09			6.2E+13
Cl-36	3.0E+05	4.0E+08	2.4E+06	3.0E+07	9.7E+06	9.0E+05		4.4E+06	4.5E+08
Cm-244	1.8E+01		2.3E+09	3.4E+09	3.8E+10	6.7E+08		5.9E+10	1.0E+11
Co-60	5.3E+00	1.7E+13	6.9E+11	8.4E+12	5.5E+13	2.1E+11	6.7E+12	1.2E+12	8.9E+13
Cs-134	2.1E+00	4.8E+10	2.3E+12	4.4E+11	3.4E+11	1.0E+12			4.1E+12
Cs-135	2.3E+06		4.4E+07	1.5E+07	1.7E+06	1.6E+07		9.5E+04	7.8E+07
Cs-137 +Ba-137m	3.0E+01	3.2E+11	6.4E+13	2.2E+13	3.2E+12	2.0E+13		1.3E+11	1.1E+14
Eu-152	1.3E+01	7.8E+11	2.2E+12	6.1E+08	1.6E+10	6.1E+11			3.6E+12
Eu-154	8.8E+00	3.2E+11		4.7E+08	8.8E+11				1.2E+12
Eu-155	5.0E+00	1.5E+10		3.2E+09	2.6E+10				4.5E+10
Fe-55	2.7E+00	2.2E+12	4.0E+10	5.1E+12	1.9E+14	1.6E+10	1.8E+13	2.0E+12	2.2E+14
H-3	1.2E+01	8.8E+13	4.8E+13	2.4E+14	9.4E+13	1.3E+13	3.2E+09	0.0E+00	4.8E+14
I-129	1.6E+07	2.6E+05	5.2E+07	5.2E+06	6.4E+04	1.9E+07		2.2E+04	7.7E+07
Ir-192m	2.4E+02						4.7E+07		4.7E+07
Mo-93	3.5E+03						3.8E+08		3.8E+08
Nb-93m	1.4E+01						1.3E+11		1.3E+11
Nb-94	2.0E+04		8.8E+09	1.6E+08	2.4E+09	3.3E+09	4.8E+06	4.5E+10	5.9E+10
Ni-59	7.5E+04	1.6E+10	4.7E+07	1.8E+10	2.1E+10	1.8E+07	2.3E+11	1.7E+09	2.8E+11
Ni-63	9.6E+01	2.1E+12	6.0E+09	2.5E+12	3.1E+12	2.1E+09	3.2E+13	2.1E+11	4.0E+13
Np-237	2.1E+06		4.7E+04	1.8E+06	3.6E+06	1.8E+04		8.7E+05	6.3E+06
Pt-193	5.0E+01						4.4E+09		4.4E+09
Pu-238	8.8E+01	1.1E+06	2.0E+08	6.9E+09	9.8E+09	7.0E+07		3.8E+09	2.1E+10
Pu-239	2.4E+04	1.5E+06	3.0E+08	1.6E+10	2.3E+10	1.1E+08		5.7E+09	4.5E+10
Pu-240	6.5E+03	2.2E+06	4.4E+08	2.4E+10	3.3E+10	1.6E+08		8.3E+09	6.6E+10
Pu-241	1.4E+01	4.4E+06	5.1E+08	2.4E+12	2.7E+12	1.4E+08		1.7E+10	5.1E+12
Pu-242	3.8E+05	2.2E+03	4.5E+05	1.8E+07	3.4E+07	1.7E+05		8.3E+06	6.1E+07
Ru-106	1.0E+00	8.4E+10	5.7E+11	1.6E+08	5.0E+12	2.9E+11			5.9E+12
Sb-125	2.8E+00	1.6E+11	1.1E+11	2.9E+11	2.1E+12	4.3E+10	1.7E+13	2.6E+11	2.0E+13
Se-79	3.8E+05	1.3E+04	1.5E+06	5.4E+05	6.6E+03	5.7E+05		3.3E+03	2.6E+06
Sm-151	9.0E+01		1.4E+08	4.7E+07	5.6E+06	4.8E+07		2.9E+05	2.4E+08
Sn-121m	5.5E+01						7.9E+11		7.9E+11
Sn-126	2.1E+05		2.3E+08	8.0E+07	8.8E+06	8.7E+07		5.0E+05	4.1E+08

Report

OPG Proprietary		
Document Number:	00216-REP-03902-00003	Usage Classification: <b>INFORMATION</b>
Sheet Number:	Revision Number: R003	Page: 20 of 136

Title:

**REFERENCE LOW- AND INTERMEDIATE-LEVEL WASTE INVENTORY FOR THE DEEP GEOLOGIC REPOSITORY**

		Decay Corrected Radionuclide Inventory (Bq)							
		Moderator IX Resin	PHT IX Resin	Misc. IX Resin	CAN-DECON Resin	IX Columns	Irradiated Core Comp.	Filters and Filter Elements	Total
<b>Net Volume (m<sup>3</sup>)</b>		1,174	802	1,097	1,427	299	23	606	5,428
Nuclide	T-1/2 (yrs)								
Sr-90+Y-90	2.9E+01	2.4E+10	3.6E+11	1.8E+12	6.8E+13	1.1E+11	5.2E+09	6.2E+10	7.0E+13
Tc-99	2.1E+05		1.7E+08	5.9E+06	2.0E+06	6.3E+07	3.6E+08	8.9E+05	6.0E+08
U-234	2.5E+05		5.0E+05	1.9E+07	3.9E+07	1.9E+05		9.2E+06	6.7E+07
U-235	7.0E+08		8.0E+03	3.2E+05	6.1E+05	3.0E+03		1.5E+05	1.1E+06
U-236	2.3E+07		9.6E+04	3.5E+06	7.0E+06	3.6E+04		1.7E+06	1.2E+07
U-238	4.5E+09	3.2E+03	6.2E+05	2.4E+07	4.7E+07	2.3E+05		1.1E+07	8.3E+07
Zr-93	1.5E+06	5.3E+05	1.5E+06	7.4E+04	6.4E+06	5.7E+05	5.7E+11	6.5E+05	5.7E+11
<b>Totals as listed</b>		<b>3.3E+15</b>	<b>1.9E+14</b>	<b>3.6E+14</b>	<b>4.3E+14</b>	<b>6.1E+13</b>	<b>7.7E+13</b>	<b>1.1E+13</b>	<b>4.4E+15</b>
<b>Totals with other short lived</b>		<b>3.3E+15</b>	<b>1.9E+14</b>	<b>3.6E+14</b>	<b>4.5E+14</b>	<b>6.2E+13</b>	<b>7.8E+13</b>	<b>1.2E+13</b>	<b>4.4E+15</b>

Note: Nuclides with half lives greater than 1 yr are shown, plus short-lived progeny.



Report

OPG Proprietary		
Document Number:	00216-REP-03902-00003	Usage Classification: <b>INFORMATION</b>
Sheet Number:	N/A	Revision Number: <b>R003</b>
		Page: <b>21 of 136</b>

Title:

**REFERENCE LOW- AND INTERMEDIATE-LEVEL WASTE INVENTORY FOR THE DEEP GEOLOGIC REPOSITORY**

Table 2.7: Estimated Operational Intermediate-Level Waste Radionuclide Inventory at 2062

		Decay Corrected Radionuclide Inventory (Bq)							
		Moderator IX Resin	PHT IX Resin	Misc. IX Resin	CAN-DECON Resin	IX Columns	Irradiated Core Comp.	Filters and Filter Elements	Total
<b>Net Volume (m<sup>3</sup>)</b>		<b>1,929</b>	<b>1,348</b>	<b>1,808</b>	<b>2,257</b>	<b>544</b>	<b>27</b>	<b>1,344</b>	<b>9,257</b>
Nuclide	T-1/2 (yrs)								
Ag-108m	1.3E+02		5.9E+08	2.0E+08	2.1E+07	2.3E+08		1.7E+06	1.0E+09
Am-241	4.3E+02		1.3E+08	4.7E+10	1.4E+11	5.0E+07		2.8E+10	2.2E+11
Am-243	7.4E+03		1.6E+06	6.1E+06	1.2E+08	6.5E+05		4.3E+07	1.7E+08
C-14	5.7E+03	5.2E+15	1.2E+14	2.7E+13	2.2E+11	4.8E+13	2.1E+12	1.5E+13	5.4E+15
Ce-141	8.9E-02	0.0E+00	0.0E+00	0.0E+00	0.0E+00	0.0E+00			0.0E+00
Cl-36	3.0E+05	6.6E+08	4.0E+06	4.9E+07	1.5E+07	1.6E+06		9.3E+06	7.4E+08
Cm-244	1.8E+01		1.3E+09	1.8E+09	1.2E+10	5.0E+08		5.4E+10	7.0E+10
Co-60	5.3E+00	1.6E+12	7.0E+10	8.2E+11	3.6E+11	2.7E+10	3.5E+11	2.2E+11	3.5E+12
Cs-134	2.1E+00	4.3E+08	2.0E+10	3.9E+09	5.3E+05	6.0E+09			3.1E+10
Cs-135	2.3E+06		7.4E+07	2.5E+07	2.7E+06	3.0E+07		2.1E+05	1.3E+08
Cs-137+ Ba-137m	3.0E+01	2.6E+11	5.4E+13	1.7E+13	1.9E+12	2.0E+13	0.0E+00	1.6E+11	9.4E+13
Eu-152	1.3E+01	3.0E+11	8.7E+11	2.3E+08	2.9E+09	3.4E+11			1.5E+12
Eu-154	8.8E+00	7.2E+10		1.1E+08	5.1E+10				1.2E+11
Eu-155	5.0E+00	1.3E+09		2.8E+08	1.2E+08				1.7E+09
Fe-55	2.7E+00	4.8E+10	8.8E+08	1.1E+11	7.3E+09	2.9E+08	1.5E+11	6.9E+10	3.8E+11
H-3	1.2E+01	3.1E+13	1.7E+13	8.3E+13	1.4E+13	6.8E+12	6.5E+08		1.5E+14
I-129	1.6E+07		8.8E+07	8.5E+06	1.0E+05	3.5E+07		5.2E+04	1.3E+08
Ir-192m	2.4E+02						4.9E+07		4.9E+07
Mo-93	3.5E+03						4.5E+08		4.5E+08
Nb-93m	1.4E+01						2.9E+10		2.9E+10
Nb-94	2.0E+04		1.5E+10	2.7E+08	3.8E+09	6.0E+09	5.6E+06	9.8E+10	1.2E+11
Ni-59	7.5E+04	2.7E+10	7.9E+07	2.9E+10	3.4E+10	3.2E+07	2.7E+11	3.5E+09	3.6E+11
Ni-63	9.6E+01	2.8E+12	8.0E+09	3.3E+12	3.6E+12	3.1E+09	2.9E+13	3.7E+11	3.9E+13
Np-237	2.1E+06		8.0E+04	2.9E+06	5.6E+06	3.2E+04	0.0E+00	2.0E+06	1.1E+07
Pt-193	5.0E+01						3.1E+09		3.1E+09
Pu-238	8.8E+01	1.8E+06	2.7E+08	8.7E+09	1.1E+10	1.0E+08		7.2E+09	2.7E+10
Pu-239	2.4E+04	2.5E+06	5.1E+08	2.7E+10	3.6E+10	2.1E+08		1.3E+10	7.7E+10
Pu-240	6.5E+03	3.6E+06	7.4E+08	4.0E+10	5.2E+10	3.0E+08		1.9E+10	1.1E+11
Pu-241	1.4E+01	7.2E+06	2.2E+08	1.0E+12	5.6E+11	8.7E+07		1.2E+10	1.6E+12
Pu-242	3.8E+05	3.7E+03	7.5E+05	2.9E+07	5.4E+07	3.0E+05		1.9E+07	1.0E+08
Ru-106	1.0E+00	1.7E+07	1.1E+08	3.2E+04	1.1E+01	2.0E+07			1.5E+08
Sb-125	2.8E+00	3.8E+09	2.5E+09	6.8E+09	1.1E+08	8.5E+08	1.5E+11	9.7E+09	1.8E+11
Se-79	3.8E+05	2.1E+04	2.6E+06	8.9E+05	1.0E+04	1.0E+06		7.4E+03	4.5E+06
Sm-151	9.0E+01		1.8E+08	6.0E+07	6.4E+06	7.1E+07		5.2E+05	3.2E+08
Sn-121m	5.5E+01						5.9E+11		5.9E+11
Sn-126	2.1E+05		3.9E+08	1.3E+08	1.4E+07	1.6E+08		1.1E+06	7.0E+08

Report

OPG Proprietary		
Document Number:	00216-REP-03902-00003	Usage Classification: <b>INFORMATION</b>
Sheet Number:	Revision Number: R003	Page: 22 of 136

Title:

**REFERENCE LOW- AND INTERMEDIATE-LEVEL WASTE INVENTORY FOR THE DEEP GEOLOGIC REPOSITORY**

		Decay Corrected Radionuclide Inventory (Bq)							
		Moderator IX Resin	PHT IX Resin	Misc. IX Resin	CAN-DECON Resin	IX Columns	Irradiated Core Comp.	Filters and Filter Elements	Total
<b>Net Volume (m<sup>3</sup>)</b>		<b>1,929</b>	<b>1,348</b>	<b>1,808</b>	<b>2,257</b>	<b>544</b>	<b>27</b>	<b>1,344</b>	<b>9,257</b>
<b>Nuclide</b>	<b>T-1/2 (yrs)</b>								
Sr-90+Y-90	2.9E+01	1.9E+10	2.8E+11	1.4E+12	4.0E+13	1.1E+11	2.6E+09	7.8E+10	4.2E+13
Tc-99	2.1E+05		2.8E+08	9.8E+06	3.2E+06	1.1E+08	4.3E+08	1.9E+06	8.4E+08
U-234	2.5E+05		8.5E+05	3.1E+07	6.1E+07	3.4E+05		2.1E+07	1.1E+08
U-235	7.0E+08		1.3E+04	5.2E+05	9.7E+05	5.4E+03		3.6E+05	1.9E+06
U-236	2.3E+07		1.6E+05	5.8E+06	1.1E+07	6.5E+04		4.1E+06	2.1E+07
U-238	4.5E+09		1.1E+06	4.0E+07	7.4E+07	4.2E+05		2.7E+07	1.4E+08
Zr-93	1.5E+06	8.7E+05	2.6E+06	1.2E+05	1.0E+07	1.0E+06	6.7E+11	1.5E+06	6.7E+11
<b>Totals as listed</b>		<b>5.2E+15</b>	<b>1.9E+14</b>	<b>1.3E+14</b>	<b>6.1E+13</b>	<b>7.5E+13</b>	<b>3.3E+13</b>	<b>1.6E+13</b>	<b>5.7E+15</b>
<b>Totals with other short lived</b>		<b>5.2E+15</b>	<b>1.9E+14</b>	<b>1.3E+14</b>	<b>6.1E+13</b>	<b>7.5E+13</b>	<b>3.4E+13</b>	<b>1.6E+13</b>	<b>5.7E+15</b>

Note: Nuclides with half lives greater than 1 yr are shown, plus short-lived progeny.

Report

<b>OPG Proprietary</b>		
Document Number:	<b>00216-REP-03902-00003</b>	Usage Classification: <b>INFORMATION</b>
Sheet Number:	<b>N/A</b>	Revision Number: <b>R003</b>
		Page: <b>23 of 136</b>

Title:  
**REFERENCE LOW- AND INTERMEDIATE-LEVEL WASTE INVENTORY FOR THE DEEP GEOLOGIC REPOSITORY**

**Table 2.8: Inventory of Non-Radioactive Components in Operational Low- and Intermediate-Level Waste**

Non-rad Component	Estimated Inventory at 2052 (kg)														
	Bottom Ash (Old)	Baghouse Ash (Old)	Bottom Ash (New)	Baghouse Ash (New)	Compact Bales/Box Compacted	Non-pro*	Heat Exchangers	CANDECON Resin	Misc. IX Resin	LL/ALW Resin	ALW Sludge	PHT IX Resin/IX Columns	Moderator IX Resin	Filters and Filter Elements	Core Components #
Volume (m <sup>3</sup> )	806	55	1,227	309	16,378	66,625	2,775	2,257	1,808	3,393	3,569	1,892	1,929	1,344	27
Aluminum	1.8E+04		2.8E+04	1.7E+02	4.1E+04	1.9E+05		2.3E+01	1.8E+02	3.1E+01	9.6E+01	1.2E+02	9.7E+00	3.5E+03	
Antimony	5.5E+02		8.8E+02	1.2E+02	1.2E+03	4.8E+02		1.1E-01	3.7E-01	8.7E-02	3.2E-01	7.9E-01	7.1E-01		
Arsenic	6.6E+01		5.8E+00	5.3E-01	1.5E+02	6.0E+01		1.2E+00	2.3E+00	3.6E-01	8.0E-02	8.4E+00	4.6E-01		
Barium	1.6E+03		2.4E+03	6.0E+00	3.8E+03	1.5E+03		5.2E-01	1.9E+01	6.6E+01	5.2E+01	1.3E+02	9.7E+00		
Beryllium			8.8E-01	1.0E-01		1.1E+02		6.9E-01	5.2E-01	3.1E-01	8.0E-02	1.9E+01	8.2E-01		
Bismuth			4.6E+00	7.1E-01				3.3E+00	2.8E-01	4.8E-02	8.0E-02	8.2E-01	8.2E-01		
Boron	3.0E+02		2.4E+02	4.2E+00	6.7E+02	2.7E+02	8.1E+00	7.8E+01	2.4E+02	1.3E+00	3.6E+01	4.0E+01	6.9E+02	4.2E+03	
Bromine								2.0E-01	2.2E-01	1.3E+02					
Cadmium	3.4E+00		8.8E+00	2.4E+00	8.0E+03	3.2E+03		4.0E+00	2.7E+00	5.9E-01	1.5E-01	1.1E-01	1.2E+01		
Calcium	3.0E+04	7.5E+01	1.0E+05	3.7E+04	6.7E+04	5.8E+04	8.1E+00	2.2E+01	3.8E+03	5.3E+04	1.2E+03	1.5E+02	1.1E+02		
Cerium										1.3E-01			8.2E-02		
Carbon	6.0E+04	9.0E+03	1.3E+04	2.9E+04	4.9E+06	2.3E+05	1.9E+03	5.8E+05	4.9E+05	9.2E+05		5.8E+05	5.9E+05	1.1E+05	
Cesium			3.8E-01	5.7E-02				2.0E-02	1.0E-01	2.8E-02	8.0E-02	9.0E-02			
Chlorine	2.2E+03	2.1E+03	4.8E+03	4.7E+03	8.7E+03	5.5E+04		1.3E+00	8.9E+01	4.3E+03		3.7E+02	1.0E+03	3.4E+03	
Chromium	3.8E+03		2.5E+03	1.2E+01	8.5E+03	3.9E+05	2.8E+02	1.7E+01	1.1E+01	2.8E+00	1.1E+00	2.6E+01	2.1E+01	3.1E+04	4.8E+03
Cobalt	6.6E+01		6.6E+01	5.3E-01	1.5E+02	5.8E+01		1.8E+01	3.1E+00	1.8E+00	1.3E-01	2.4E-01	1.0E+00		
Copper	1.3E+04		5.2E+03	2.4E+01	2.8E+04	1.9E+06	1.4E+06	1.3E+02	3.1E+03	1.6E+02	4.8E+00	2.3E+01	7.4E+02		
Fluorine													1.3E+02		
Gadolinium								1.3E-01	8.3E+00			1.0E+03	4.4E+03		
Hydrogen								1.5E+05	1.2E+05	2.2E+05		1.4E+05	1.4E+05	2.1E+04	
Iodine								4.8E-02	6.2E-02	6.6E+01					
Iron	2.5E+04	7.5E+01	5.0E+04	3.1E+02	4.3E+06	3.2E+06	3.0E+05	3.4E+04	1.9E+03	2.3E+02	1.1E+02	5.6E+02	7.9E+02	8.6E+05	2.4E+03
Lead	7.1E+03		6.0E+02	6.0E+01	1.6E+04	1.5E+06	4.1E+02	8.2E+01	9.6E+01	7.9E+00	3.0E+00	1.1E+01	9.2E+01		
Lithium			4.1E+01	9.4E-01				1.3E+01	1.9E+02	2.0E+00	7.6E-01	5.3E+03	3.9E+02		
Magnesium	4.4E+03		2.0E+04	4.6E+02	9.7E+03	9.4E+03	2.2E+04	1.0E+01	8.5E+02	5.6E+03	2.9E+02	3.4E+01	1.4E+01		
Manganese	2.2E+03		9.5E+02	1.1E+01	4.4E+04	2.5E+04	6.1E+05	5.2E+02	7.6E+01	4.1E+01	1.0E+01	9.0E+01	2.5E+01	5.5E+03	
Mercury	1.1E+01		8.8E-01	5.2E-02	3.4E+01	2.2E+01		8.1E-02	3.3E-02	3.1E-01	8.0E-02	1.1E-01	6.2E-02		
Molybdenum			2.1E+02	3.0E+00				2.8E+00	3.8E+00	2.2E+00	1.1E-01	3.9E+01	2.6E+00		
Nickel	1.1E+03		9.5E+02	1.0E+01	2.5E+03	2.5E+04	7.9E+02	4.3E+03	3.3E+02	3.8E+01	9.6E+00	1.1E+01	4.6E+03	1.9E+04	1.7E+04
Niobium	2.2E+01				5.7E+01	2.3E+01									
Nitrate ion	2.9E+04				6.4E+04	2.5E+04		1.0E+00	3.3E+01				6.2E+02		
Nitrogen								1.2E+04	2.7E+04	5.6E+04		3.2E+04	3.3E+04	2.4E+02	

Report

<b>OPG Proprietary</b>		
Document Number: <b>00216-REP-03902-00003</b>	Usage Classification: <b>INFORMATION</b>	
Sheet Number: <b>N/A</b>	Revision Number: <b>R003</b>	Page: <b>24 of 136</b>

Title: **REFERENCE LOW- AND INTERMEDIATE-LEVEL WASTE INVENTORY FOR THE DEEP GEOLOGIC REPOSITORY**

Non-rad Component	Estimated Inventory at 2052 (kg)														
	Bottom Ash (Old)	Baghouse Ash (Old)	Bottom Ash (New)	Baghouse Ash (New)	Compact Bales/Box Compacted	Non-pro*	Heat Exchangers	CANDECON Resin	Misc. IX Resin	LL/ALW Resin	ALW Sludge	PHT IX Resin/IX Columns	Moderator IX Resin	Filters and Filter Elements	Core Components #
Oxygen								1.0E+06	6.5E+05	1.2E+06		7.7E+05	7.9E+05	1.4E+04	
Phosphorus	1.6E+03	8.6E+02	1.1E+04	2.3E+02	2.1E+04	7.6E+04		1.5E+02	2.8E+02	8.4E+01	2.4E+01	1.6E+02	2.6E+02	2.4E+03	
Potassium	1.6E+03		3.4E+03	1.7E+02	3.6E+03	1.7E+03		2.5E+02	1.1E+03	2.1E+02	2.6E+02	1.6E+02	3.6E+01		
Rubidium										2.4E-01					
Volume (m3)	806	55	1,227	309	16,378	66,625	2,775	2,257	1,808	3,393	3,569	1,892	1,929	1,344	27
Scandium	2.2E+01		8.8E-01										5.6E-02		
Selenium					5.7E+01	2.3E+01		6.6E-01	2.6E+00	7.9E-01	5.6E-01	8.0E-01	8.2E-01		
Silicon	2.0E+04	1.7E+02	5.6E+04	1.0E+03	4.3E+05	2.7E+06	3.9E+02	3.2E+01	1.1E+02	6.4E+01	2.5E+02	1.8E+02	2.5E+01	9.4E+04	
Silver			3.8E+00	2.9E-01				1.1E-01	2.2E-01	9.4E-01	1.0E-01	1.8E-01	4.6E-01		
Sodium	3.3E+03	9.0E+02	8.1E+03	1.2E+03	9.0E+03	1.6E+05		1.7E+02	2.7E+03	1.3E+03	2.4E+04	3.2E+02	1.3E+02	8.3E+03	
Strontium	5.5E+02		3.0E+02	1.8E+01	1.2E+03	6.0E+02		1.7E-01	3.1E+01	5.6E+02	1.3E+01	1.6E+00	5.4E-01		
Sulphur	1.1E+03	1.4E+03	6.8E+03	1.6E+03	5.7E+03	3.9E+04	1.4E+03	1.5E+05	4.2E+04	1.4E+05		5.3E+04	5.1E+04	2.4E+03	
Tellurium	4.9E+01				1.1E+02	4.4E+01									
Thallium			1.0E-01	2.3E-02				8.9E-02	3.0E-02	3.8E-02	8.0E-02	8.0E-02	8.2E-02		
Thorium			5.4E+00	3.7E-02				1.5E+00	9.9E-02	3.8E-02	6.8E-02	8.0E-02	8.2E-02		
Tin			1.3E+02	6.1E+00				7.5E+00	1.4E+00	6.1E-01	2.6E-01	5.3E+00	1.6E+00		
Titanium	8.8E+03		4.6E+04	4.6E+01	2.0E+04	7.1E+04	1.6E+02	2.1E+00	3.0E+01	1.1E-01	2.0E+00	6.9E-01	1.8E-01		
Tungsten								1.4E-01	1.8E+00	1.1E+00	8.0E-02	8.0E+00	1.6E-01		
Uranium			3.1E+00	2.3E-01		3.3E+02		2.1E+01	1.6E+00	2.8E-01	8.0E-02	1.8E+00	9.2E-02		
Vanadium			8.1E+01	8.3E+00				5.5E-02	1.9E+00	2.8E-01	8.0E-02	2.3E+00	8.2E-02		
Zinc	2.2E+04	9.6E+02	1.2E+04	4.1E+02	5.1E+04	4.4E+04	1.6E+04	6.8E+01	1.5E+03	1.3E+02	1.2E+02	6.1E+01	4.1E+02		
Zirconium	1.5E+02		1.2E+02	8.6E-01	3.3E+02	1.4E+02		6.2E-02	7.5E-01	4.1E-01	3.8E-01	1.8E-01	2.3E-01		
Asbestos						3.0E+05									
EDTA								4.8E+04							
PAH	1.3E+00	1.9E-03	1.3E-01	2.0E+00											
Cl-Benzenes & Cl-Phenols	1.8E+00	4.9E-01	3.2E-01	1.5E-01											
Dioxins & Furans	4.2E-02	1.5E-03	3.1E-02	1.8E-02											
PCB	1.1E-01	1.9E-03	1.6E-02	3.3E-03											
Balance	2.9E+05	3.2E+03	3.0E+05	4.3E+04	6.4E+06	6.5E+06	0.0E+00	0.0E+00	0.0E+00	0.0E+00	4.0E+06	0.0E+00	0.0E+00	0.0E+00	0.0E+00
<b>Total</b>	<b>5.5E+05</b>	<b>1.9E+04</b>	<b>6.8E+05</b>	<b>1.2E+05</b>	<b>1.6E+07</b>	<b>1.7E+07</b>	<b>2.3E+06</b>	<b>2.1E+06</b>	<b>1.4E+06</b>	<b>2.7E+06</b>	<b>4.0E+06</b>	<b>1.6E+06</b>	<b>1.6E+06</b>	<b>1.2E+06</b>	<b>2.4E+04</b>

\* Includes feeder pipes, encapsulated tile holes, and drummed non-pro waste.  
 # Based on 138 liners containing 690 flux detectors, and avg. flux detector mass for Pickering.

Report

<b>OPG Proprietary</b>		
Document Number:	<b>00216-REP-03902-00003</b>	Usage Classification:
		<b>INFORMATION</b>
Sheet Number:	Revision Number:	Page:
<b>N/A</b>	<b>R003</b>	<b>25 of 136</b>

Title: **REFERENCE LOW- AND INTERMEDIATE-LEVEL WASTE INVENTORY FOR THE DEEP GEOLOGIC REPOSITORY**

Table 2.9: Inventory of Low-Level Waste Container Materials

Container Type	Container Count	Total Mass (kg)					Total External Surface Area (m <sup>2</sup> )			
		Carbon Steel (Container)	Carbon Steel (Overpack)	Copper Alloy	Plastics	Concrete	Carbon Steel (Container)	Carbon Steel (Overpack)	Plastics	Cu/Ni (Tubes)
Ash Bin (Old) – bottom ash	250	1.7E+05	4.0E+05				4.0E+03	6.3E+03		
Ash Bin (New) – bottom ash	632	2.4E+05	1.0E+06				6.9E+03	1.6E+04		
Drum Rack (Old) – baghouse ash	46	1.9E+04	7.3E+04				7.4E+02	1.2E+03		
Ash Bin (New) – baghouse ash	172	6.5E+04	2.7E+05				1.9E+03	4.4E+03		
Compactor Box	6,135	3.0E+06					7.2E+04			
Bale Rack	1,383	2.1E+05	2.5E+05				3.9E+03	1.9E+04		
Drum Rack	3,225	1.4E+06	5.1E+05				9.8E+04	8.2E+03		
Drum Bin	4,615	2.6E+06					5.5E+04			
Non-Pro Container (NPB4, NPB47)	24,164	8.5E+06					3.1E+05			
Shield Plug Container	26	3.4E+05					7.3E+02			
Heat Exchanger	98	2.8E+05		2.1E+06			3.5E+03			9.8E+04
Encapsulated Tile Hole	66	1.1E+05				1.5E+06	1.4E+03			
Low Level Resin Box (90")	80	9.4E+04	1.3E+05				1.3E+03	2.0E+03		
Low Level Resin Pallet Tank	2,085	4.6E+05	3.0E+05		2.1E+05		7.9E+03	2.4E+04	2.4E+04	
ALW Sludge Box	1,709	6.5E+05	2.7E+06				2.0E+04	4.3E+04		
<b>TOTAL</b>	<b>44,686</b>	<b>1.8E+07</b>	<b>5.7E+06</b>	<b>2.1E+06</b>	<b>2.1E+05</b>	<b>1.5E+06</b>	<b>5.9E+05</b>	<b>1.2E+05</b>	<b>2.4E+04</b>	<b>9.8E+04</b>

**Note:** Feeder pipes are included in the non-pro container inventory and will be stored in non-pro high capacity containers similar to the NPB47s.  
 Heat exchanger data based on dimensions/weights of Pickering Moderator HX.  
 Steel coverage for bale racks and LL resin pallet tanks factored in totals.

Report

OPG Proprietary		
Document Number:	00216-REP-03902-00003	Usage Classification: <b>INFORMATION</b>
Sheet Number:	Revision Number:	Page:
N/A	R003	26 of 136

Title: **REFERENCE LOW- AND INTERMEDIATE-LEVEL WASTE INVENTORY FOR THE DEEP GEOLOGIC REPOSITORY**

Table 2.10: Inventory of Intermediate-Level Waste Container Materials

Container Type	Container Count	Total Mass (kg)					Total External Surface Area (m <sup>2</sup> )			
		Carbon Steel (Container)	Stainless Steel (Container)	Stainless Steel (Overpack)	Concrete (Shield)	Carbon Steel (rebar in shield)*	Carbon Steel (Container)	Stainless Steel (Container)	Stainless Steel (Overpack)	Concrete (Shield)
Resin Liner <sup>#</sup>	2,447	5.3E+05	1.4E+06	5.8E+05	1.9E+07	3.9E+05	9.0E+03	2.4E+04	5.7E+03	3.5E+04
ATHEL Waste Package <sup>##</sup>	300		2.1E+05		6.3E+06	1.3E+05		4.0E+03		9.5E+03
ILW Shield	3,952				7.8E+06	1.6E+05				2.7E+04
Tile Hole Liner	201	9.0E+04					1.3E+03			
<b>TOTAL</b>	<b>6,900</b>	<b>6.2E+05</b>	<b>1.6E+06</b>	<b>5.8E+05</b>	<b>3.3E+07</b>	<b>6.8E+05</b>	<b>1.0E+04</b>	<b>2.8E+04</b>	<b>5.7E+03</b>	<b>7.2E+04</b>

**Note:** CANDECON resins are included in the resin liner inventory.

\* Rebar in shield construction is assumed to be 2% of empty weight.

# 1777 are stainless steel liners, and 670 are carbon steel liners, 400 of which are packed in stainless steel overpacks.

## assumed to be in concrete shields, one container per shield, similar to resin liner RLSHLD3, but without inner steel shielding.

Report

OPG Proprietary		
Document Number:	00216-REP-03902-00003	Usage Classification: <b>INFORMATION</b>
Sheet Number:	N/A	Revision Number: R003
		Page: 27 of 136

Title:  
**REFERENCE LOW- AND INTERMEDIATE-LEVEL WASTE INVENTORY FOR THE DEEP GEOLOGIC REPOSITORY**

Table 2.11: Inventory of Bulk Materials in Low-Level Waste

Waste Stream	Container Count	Ash	Total Organic Materials (kg)						Concrete (kg)	Carbon Steel (kg)	Stainless Steel (kg)	Other Metal (kg)	Other Inorganics (kg)
			Cellulose	Rubber	Plastics <sup>-</sup>	Resins <sup>+</sup>	Bitumen	Other Organics					
Bottom Ash (old + new)	882	1.2E+06											
Baghouse Ash (old + new)	218	1.4E+05											
Compact Bales	1,383		4.9E+05	1.2E+05	6.4E+05			5.2E+04		2.6E+05			
Box Compacted	6,135		4.0E+06	9.9E+05	5.2E+06			4.2E+05		2.1E+06			
Non-Pro*	24,190		2.2E+06	2.6E+05	6.4E+05		1.9E+05	2.6E+05	7.7E+05	1.3E+06	1.4E+06	3.4E+06	3.6E+06
Non-pro Drummed	7,840		4.9E+05	9.4E+04	2.4E+05			3.3E+05	2.8E+05	4.7E+05	4.7E+05		1.3E+06
Non-pro Other	164					1.6E+04				4.8E+03			
LL/ALW Resin	2,165					1.5E+06							
ALW Sludge	1,709												4.0E+06
<b>TOTAL</b>	<b>44,686</b>	<b>1.3E+06</b>	<b>7.2E+06</b>	<b>1.5E+06</b>	<b>6.7E+06</b>	<b>1.5E+06</b>	<b>1.9E+05</b>	<b>1.1E+06</b>	<b>1.1E+06</b>	<b>4.1E+06</b>	<b>1.9E+06</b>	<b>3.4E+06</b>	<b>8.9E+06</b>

+ LL resin/ALW resin weight does not include weight of bound (approx 40% by weight) or interstitial water.

\* Includes shield plugs and feeder pipes.

- Includes plastic bag inventory.

Table 2.12: Inventory of Bulk Materials in Intermediate-Level Waste

Waste Type	Total Mass (kg)					
	Resins	Carbon Steel	Stainless Steel	Glass Fibre	Polypropylene	Low Density PolyEthylene
ILW Resin (PHT, Moderator, Misc., CANDECON)	3.7E+06					
IX Columns	1.9E+05	4.0E+05				
Filters and Filter Elements		5.0E+05	9.2E+04	7.4E+04	8.6E+04	1.2E+04
Irradiated Core Components*		1.3E+04	4.8E+02			
<b>TOTAL</b>	<b>3.9E+06</b>	<b>9.1E+05</b>	<b>9.2E+04</b>	<b>7.4E+04</b>	<b>8.6E+04</b>	<b>1.2E+04</b>

Note: ILW resin weight does not include bound water (approx ~40% by weight) or interstitial water.

\* Assumes 1 PNGSB vertical flux detector in a flux detector line.

Report

OPG Proprietary		
Document Number:	00216-REP-03902-00003	Usage Classification: <b>INFORMATION</b>
Sheet Number:	Revision Number: R003	Page: 28 of 136

Title:

**REFERENCE LOW- AND INTERMEDIATE-LEVEL WASTE INVENTORY FOR THE DEEP GEOLOGIC REPOSITORY**

**3.0 PROJECTED RETUBE AND STEAM GENERATOR REFURBISHMENT WASTE INVENTORY AND CHARACTERISTICS**

**3.1 Waste Volumes and Package Inventory**

Reactor refurbishment consists of large scale retube (replacing the pressure tubes, calandria tubes and/or endfittings) and/or replacing the steam generators. Based on their radiological properties, retube components and steam generators are classified as ILW and LLW respectively.

Table 3.1 summarizes the forecast refurbishment waste inventory, including reference assumptions for disposal based on “Scenario B”. Two types of boxes are envisioned for retube component waste: one for volume reduced components (pressure tubes, calandria tubes and calandria tube inserts), and one for uncut end fittings. Historic retube waste from the Pickering A retube is not included in the inventory. This waste is assumed to be retrieved from Dry Storage Modules at Pickering at the time of station decommissioning, and then cut and repackaged and co-disposed with the Pickering decommissioning ILW.

The waste volume forecasts are subject to changes to the nuclear operating and refurbishment program; improvements to waste storage technology; standardization across stations; and disposal technology. There are also uncertainties related to the packages for newer “hotter” pressure tube wastes that will arise from future refurbishment activities.

**Table 3.1: Scenario B Reactor Refurbishment Waste Forecast Summary by Waste Type**

Waste Type	Net Volume (m <sup>3</sup> )	Number of Containers	Emplaced Volume (m <sup>3</sup> )	Reference Assumptions for DGR
Retube Waste - Pressure Tubes	193	242	1,860	From PWWF and DWWF, put in transport overpack and transport to DGR as-is. From WWMF, transfer as-is.
Retube Waste - End Fittings	2,429	899	9,804	Assumptions same as pressure tube re-tube waste.
Retube Waste - Calandria Tubes	133	167	1,285	Assumptions same as pressure tube re-tube waste.
Retube Waste - Calandria Tube Inserts	36	45	349	Assumptions same as pressure tube re-tube waste.
Steam Generators (SG)	8,387	512	8,387	Assume each SG from Bruce-A will be cut into 5 segments, each SG from Bruce-B will be cut into 8 segments, and each SG from Pick-B will be cut into 6 segments. Seal plates to be welded prior to transfer/transport to DGR.
<b>Totals</b>	<b>11,178</b>	<b>1,865</b>	<b>21,685</b>	



## Report

OPG Proprietary		
Document Number:	00216-REP-03902-00003	Usage Classification: <b>INFORMATION</b>
Sheet Number:	Revision Number: R003	Page: 29 of 136

Title:

### **REFERENCE LOW- AND INTERMEDIATE-LEVEL WASTE INVENTORY FOR THE DEEP GEOLOGIC REPOSITORY**

## 3.2 Radionuclide Inventory

Activation calculations for Pickering B, Bruce A Units 1 to 4, and Darlington pressure tubes, calandria tubes, calandria tube sleeve inserts, and the “hot” ends of end fittings were performed using the isotope generation and depletion code ORIGEN-S [Hermann and Westfall 1995] for an assumed irradiation period and capacity factor. The code calculates time-dependent concentrations of isotopes, which are simultaneously generated through neutronic transmutation, fission, and radioactive decay.

Pickering B radionuclide activity concentrations for the significant nuclides present in retube components are reported in Appendix B for a decay period of 5 years, which represents the assumed decay time of the waste before it is transferred to the DGR. The Pickering B data is included in Appendix B because it is considered to be representative of the data for all stations. However, specific Bruce A and Darlington data are used for the calculations to determine total activity at 2018 and 2062.

The activity concentrations are primarily based on activation of the base metal. The contribution from surface contamination is included for pressure tubes based on data from outlet feeder pipes, but is expected to be minimal on other retube components. A previous study on Bruce A calandria swabs indicated the presence of mainly corrosion products, primarily zirconium alloy debris, with very little C-14 or fission product contamination.

The specific activities for steam generators are based on data for Bruce A tube sections (see Appendix B), and are considered to apply to steam generators at Bruce B and Pickering B. The activities were based on measurements of the internal oxide at several locations along the length of these tubes, and recent gamma scans of Bruce A steam generators in storage.

Tables 3.2 and 3.3 present the radionuclide inventories for refurbishment wastes for “Scenario B” at 2018 and 2062 respectively.

Report

OPG Proprietary		
Document Number:	00216-REP-03902-00003	Usage Classification: <b>INFORMATION</b>
Sheet Number:	Revision Number: R003	Page: 30 of 136

Title:

**REFERENCE LOW- AND INTERMEDIATE-LEVEL WASTE INVENTORY FOR THE DEEP GEOLOGIC REPOSITORY**

Table 3.2: Estimated Reactor Refurbishment Radionuclide Inventory at 2018

Nuclide	T-1/2 (yrs)	Decay Corrected Radionuclide Inventory (Bq)					Total
		Retube Waste Pressure Tubes	Retube Waste End Fittings	Retube Waste Calandria Tubes	Retube Waste Calandria Tube Inserts	Steam Generators	
<b>Net Volume (m<sup>3</sup>)</b>		<b>49</b>	<b>600</b>	<b>34</b>	<b>9</b>	<b>8,387</b>	<b>9,079</b>
Ag-108m	1.3E+02	3.6E+12	6.8E+10	2.2E+12	8.1E+08	3.7E+05	5.9E+12
Am-241	4.3E+02	3.5E+09		5.8E+08	8.7E+04	4.8E+11	4.8E+11
Am-242m	1.5E+02	5.8E+06		1.1E+06	2.2E+03	2.3E+09	2.3E+09
Am-243	7.4E+03			2.6E+08	9.5E+01	5.6E+08	8.2E+08
C-14	5.7E+03	1.4E+14	4.2E+12	1.0E+13	1.1E+11	2.2E+11	1.5E+14
Cl-36	3.0E+05	3.5E+11	4.2E+08	2.6E+10	5.6E+06	1.2E+07	3.8E+11
Cm-243	2.9E+01	6.8E+06		8.3E+06	7.2E+01	2.7E+09	2.7E+09
Cm-244	1.8E+01			1.6E+11	1.4E+03	1.8E+11	3.4E+11
Co-60	5.3E+00	2.3E+14	4.2E+15	1.5E+14	6.7E+13	3.5E+12	4.7E+15
Cs-134	2.1E+00	6.9E+10	4.0E+10	1.7E+09	4.7E+08	1.5E+08	1.1E+11
Cs-135	2.3E+06	3.2E+07	1.5E+04	5.7E+06	3.9E+02	3.6E+04	3.8E+07
Cs-137/Ba-137m	3.0E+01	2.0E+09	8.8E+01	1.2E+12	1.4E+07	5.8E+10	1.3E+12
Eu-152	1.3E+01	8.8E+02		1.7E+06	5.4E+03	1.8E+09	1.8E+09
Eu-154	8.8E+00	9.1E+06		7.2E+09	3.5E+04	1.3E+10	2.0E+10
Eu-155	5.0E+00	1.7E+06		4.0E+08	4.1E+03	1.3E+10	1.3E+10
Fe-55	2.7E+00	7.9E+14	4.2E+16	3.9E+14	6.7E+14	3.1E+12	5.3E+16
H-3	1.2E+01	8.0E+11	3.0E+12	3.2E+11	5.7E+10	8.5E+11	5.0E+12
I-129	1.6E+07	1.0E+05	4.6E+03	5.0E+05	4.9E+01	1.3E+04	6.2E+05
Ir-192m	2.4E+02	2.2E+09	2.4E+04	7.4E+07	3.8E+02		2.3E+09
Mn-54	8.6E-01	6.9E+11	1.7E+14	2.2E+11	1.7E+12	4.0E+08	1.7E+14
Mo-93	3.5E+03	8.5E+09	8.0E+10	5.4E+09	8.4E+08		9.5E+10
Nb-93m	1.4E+01	1.4E+13	2.4E+10	6.6E+12	2.7E+08		2.1E+13
Nb-94	2.0E+04	1.2E+15	6.4E+10	7.3E+10	6.9E+08	4.9E+08	1.2E+15
Ni-59	7.5E+04	6.9E+10	2.4E+12	6.4E+11	3.1E+10	1.0E+10	3.2E+12
Ni-63	9.6E+01	2.4E+13	2.4E+14	2.3E+14	3.3E+12	1.4E+12	5.0E+14
Np-237	2.1E+06	1.7E+04		5.4E+04	2.1E+06	2.7E+07	2.9E+07
Pt-193	5.0E+01	3.4E+12	9.6E+09	9.7E-85	1.1E+08		3.4E+12
Pu-238	8.8E+01	1.2E+09		6.6E+08	4.2E+04	1.3E+11	1.3E+11
Pu-239	2.4E+04	2.1E+09		8.7E+07	5.5E+04	1.7E+11	1.7E+11
Pu-240	6.5E+03	2.9E+09		7.2E+08	4.8E+04	2.5E+11	2.5E+11
Pu-241	1.4E+01	4.7E+10		1.7E+10		3.9E+12	3.9E+12
Pu-242	3.8E+05	3.2E+06		1.0E+07		2.5E+08	2.6E+08
Sb-125	2.8E+00	2.2E+12	7.4E+12	7.5E+14	8.0E+10	3.3E+09	7.6E+14
Se-79	3.8E+05	5.6E+08	3.0E+07	1.7E+09	3.3E+05	1.3E+03	2.3E+09

Report

OPG Proprietary		
Document Number:	00216-REP-03902-00003	Usage Classification: <b>INFORMATION</b>
Sheet Number:	Revision Number: R003	Page: 31 of 136

Title:

**REFERENCE LOW- AND INTERMEDIATE-LEVEL WASTE INVENTORY FOR THE DEEP GEOLOGIC REPOSITORY**

		Decay Corrected Radionuclide Inventory (Bq)					
Nuclide	T-1/2 (yrs)	Retube Waste Pressure Tubes	Retube Waste End Fittings	Retube Waste Calandria Tubes	Retube Waste Calandria Tube Inserts	Steam Generators	Total
<b>Net Volume (m<sup>3</sup>)</b>		<b>49</b>	<b>600</b>	<b>34</b>	<b>9</b>	<b>8,387</b>	<b>9,079</b>
Sm-151	9.0E+01	4.5E+05		2.3E+09	1.4E+05	1.2E+05	2.3E+09
Sn-119m	8.0E-01	6.8E+11	2.6E+12	2.3E+14	2.9E+10		2.3E+14
Sn-121m	5.5E+01	8.1E+10	9.8E+10	3.2E+13	1.0E+09		3.2E+13
Sn-126	2.1E+05			1.1E+07	1.3E+02	1.9E+05	1.1E+07
Sr-90+Y90	2.9E+01	1.6E+12	1.9E+04	1.0E+12	1.2E+07	3.2E+12	5.8E+12
Tc-99	2.1E+05	6.7E+09	2.6E+09	2.9E+09	2.6E+07	2.4E+06	1.2E+10
U-232	7.2E+01	5.5E+05		8.5E+06	8.4E+03	2.2E+08	2.3E+08
U-233	1.6E+05	7.4E+05		6.0E+06	8.1E+04	3.0E+08	3.1E+08
U-234	2.5E+05	3.5E+06		2.1E+06		2.8E+08	2.9E+08
U-235	7.0E+08	5.4E+04		1.6E+02		4.6E+06	4.7E+06
U-236	2.3E+07	6.5E+05		4.5E+04	9.1E+00	5.3E+07	5.4E+07
U-238	4.5E+09	4.3E+06		2.4E+05		3.6E+08	3.6E+08
Zr-93	1.5E+06	3.7E+13	1.4E+07	1.7E+13	1.7E+05	6.3E+05	5.4E+13
<b>Totals as listed</b>		<b>2.4E+15</b>	<b>4.7E+16</b>	<b>1.8E+15</b>	<b>7.4E+14</b>	<b>1.3E+13</b>	<b>5.2E+16</b>
<b>Totals with other short lived</b>		<b>2.4E+15</b>	<b>4.7E+16</b>	<b>1.8E+15</b>	<b>7.5E+14</b>	<b>1.3E+13</b>	<b>5.2E+16</b>

Note: Retube inventories calculated based on assumption DGR at 2018 will contain Bruce A waste only.

Report

OPG Proprietary		
Document Number:	00216-REP-03902-00003	Usage Classification: <b>INFORMATION</b>
Sheet Number:	Revision Number: R003	Page: 32 of 136
N/A		

Title:  
**REFERENCE LOW- AND INTERMEDIATE-LEVEL WASTE INVENTORY FOR THE DEEP GEOLOGIC REPOSITORY**

Table 3.3: Estimated Reactor Refurbishment Radionuclide Inventory at 2062

Net Volume (m <sup>3</sup> )		Estimated Radionuclide Inventory (Bq)					
		Retube Waste Pressure Tubes	Retube Waste End Fittings	Retube Waste Calandria Tubes	Retube Waste Cal. Tube Inserts	Steam Generators	Total
		193	2,429	133	36	8,387	11,178
Nuclide	T-1/2 (yrs)						
Ag-108m	1.3E+02	1.2E+13	7.2E+11	6.9E+12	2.9E+10	1.4E+06	2.0E+13
Am-241	4.3E+02	1.4E+10		5.4E+08	8.1E+04	2.1E+12	2.1E+12
Am-242m	1.5E+02	2.3E+07		9.0E+05	1.8E+03	2.3E+09	2.3E+09
Am-243	7.4E+03			2.6E+08	9.5E+01	2.6E+09	2.9E+09
C-14	5.7E+03	5.5E+14	6.6E+13	3.6E+13	3.5E+12	1.0E+12	6.6E+14
Cl-36	3.0E+05	1.3E+12	6.2E+09	1.1E+11	2.9E+08	5.7E+07	1.4E+12
Cm-243	2.9E+01	2.7E+07		2.8E+06	2.5E+01	2.7E+09	2.7E+09
Cm-244	1.8E+01			2.9E+10	2.5E+02	1.9E+11	2.2E+11
Co-60	5.3E+00	9.3E+12	8.6E+14	5.3E+12	2.3E+13	1.2E+11	9.0E+14
Cs-134	2.1E+00	1.5E+06	1.5E+06	1.9E+04	4.1E+04	2.5E+03	3.1E+06
Cs-135	2.3E+06	2.2E+08	8.2E+05	8.2E+06	7.7E+04	1.7E+05	2.3E+08
Cs-137+Ba-137m	3.0E+01	6.6E+09	1.1E+05	4.2E+11	5.0E+06	1.1E+11	5.4E+11
Eu-152	1.3E+01	9.8E+01	8.8E-03	1.7E+05	5.4E+02	1.2E+09	1.2E+09
Eu-154	8.8E+00	3.5E+05	7.0E-01	2.2E+08	1.1E+03	3.0E+09	3.2E+09
Eu-155	5.0E+00	6.9E+03		8.5E+05	8.7E+00	3.3E+08	3.3E+08
Fe-55	2.7E+00	3.2E+11	5.2E+13	1.5E+11	2.8E+12	1.0E+09	5.5E+13
H-3	1.2E+01	2.4E+11	4.0E+12	6.4E+10	5.5E+10	4.8E+11	4.8E+12
I-129	1.6E+07	3.6E+05	5.4E+04	5.4E+05	1.9E+03	6.0E+04	1.0E+06
Ir-192m	2.4E+02	1.1E+10	1.2E+07	3.6E+08	1.5E+06		1.1E+10
Mn-54	8.6E-01	3.6E-01	2.6E+02	1.3E-01	1.2E+01	1.8E-04	2.7E+02
Mo-93	3.5E+03	3.2E+10	9.2E+11	1.9E+10	3.3E+10		1.0E+12
Nb-93m	1.4E+01	6.5E+12	3.4E+10	2.7E+12	1.2E+09		9.2E+12
Nb-94	2.0E+04	4.6E+15	7.4E+11	2.8E+11	2.6E+10	2.3E+09	4.6E+15
Ni-59	7.5E+04	2.7E+11	3.2E+13	2.5E+12	1.2E+12	4.8E+10	3.6E+13
Ni-63	9.6E+01	7.5E+13	3.0E+15	7.0E+14	1.4E+14	4.8E+12	3.9E+15
Np-237	2.1E+06			5.4E+04		1.2E+08	1.2E+08
Pt-193	5.0E+01	1.1E+13	7.4E+10	3.8E+11	3.0E+09		1.1E+13
Pu-238	8.8E+01	4.6E+09		4.7E+08	3.0E+04	4.6E+11	4.6E+11
Pu-239	2.4E+04	8.3E+09		8.7E+07	5.5E+04	8.1E+11	8.2E+11
Pu-240	6.5E+03	1.1E+10		7.2E+08	4.7E+04	1.2E+12	1.2E+12
Pu-241	1.4E+01	1.9E+11		2.0E+09		2.8E+12	3.0E+12
Pu-242	3.8E+05	1.3E+07		1.0E+07		1.2E+09	1.2E+09
Sb-125	2.8E+00	1.2E+09	7.6E+09	3.8E+11	2.6E+08	1.4E+06	3.9E+11
Se-79	3.8E+05	3.2E+09	5.8E+08	8.7E+09	5.5E+07	6.1E+03	1.3E+10

Report

OPG Proprietary		
Document Number:	00216-REP-03902-00003	Usage Classification: <b>INFORMATION</b>
Sheet Number:	Revision Number: R003	Page: 33 of 136
N/A		

Title:

**REFERENCE LOW- AND INTERMEDIATE-LEVEL WASTE INVENTORY FOR THE DEEP GEOLOGIC REPOSITORY**

		Estimated Radionuclide Inventory (Bq)					
		Retube Waste Pressure Tubes	Retube Waste End Fittings	Retube Waste Calandria Tubes	Retube Waste Cal. Tube Inserts	Steam Generators	Total
Net Volume (m <sup>3</sup> )		193	2,429	133	36	8,387	11,178
Nuclide	T-1/2 (yrs)						
Sm-151	9.0E+01	3.4E+05	1.6E+00	1.7E+09	9.6E+04	4.1E+05	1.7E+09
Sn-119m	8.0E-01	1.2E-01	4.6E-01	2.3E+01	1.6E-02		2.4E+01
Sn-121m	5.5E+01	2.1E+11	7.4E+11	7.6E+13	2.7E+10		7.7E+13
Sn-126	2.1E+05			1.1E+07	1.3E+02	9.1E+05	1.2E+07
Sr-90+Y-90	2.9E+01	2.4E+12	3.2E+05	9.2E+11	4.4E+06	6.0E+12	9.3E+12
Tc-99	2.1E+05	2.4E+10	2.6E+10	9.4E+09	7.5E+08	1.1E+07	6.0E+10
U-232	7.2E+01	2.2E+06		5.5E+06	5.5E+03	2.2E+08	2.3E+08
U-233	1.6E+05	2.9E+06		5.9E+06	8.1E+04	3.0E+08	3.1E+08
U-234	2.5E+05	1.4E+07		2.1E+06		1.3E+09	1.3E+09
U-235	7.0E+08	2.1E+05		1.6E+02		2.1E+07	2.1E+07
U-236	2.3E+07	2.6E+06		4.5E+04	9.1E+00	2.5E+08	2.5E+08
U-238	4.5E+09	1.7E+07		2.4E+05		1.7E+09	1.7E+09
Zr-93	1.5E+06	1.5E+14	1.9E+08	6.2E+13	8.3E+06	2.9E+06	2.1E+14
<b>Totals as listed</b>		<b>5.4E+15</b>	<b>4.0E+15</b>	<b>8.9E+14</b>	<b>1.7E+14</b>	<b>1.7E+13</b>	<b>1.1E+16</b>
<b>Totals with other short lived</b>		<b>5.4E+15</b>	<b>4.0E+15</b>	<b>9.0E+14</b>	<b>1.7E+14</b>	<b>1.7E+13</b>	<b>1.1E+16</b>

## Report

OPG Proprietary		
Document Number:	00216-REP-03902-00003	Usage Classification: <b>INFORMATION</b>
Sheet Number:	Revision Number: R003	Page: 34 of 136

Title:

## REFERENCE LOW- AND INTERMEDIATE-LEVEL WASTE INVENTORY FOR THE DEEP GEOLOGIC REPOSITORY

### 3.3 Chemical Inventory

Elemental compositions were taken from OPG design documents and other sources (see Appendix C). The inventories of elements integral to the material for each of the components/items are reported in Table 3.4. The estimates are based on “Scenario B” at 2052. The steam generator data are documented again as part of the bulk material inventory in Table 3.5.

Table 3.4: Elemental Inventory in Reactor Refurbishment Waste

Element	Pressure Tubes* (kg)	End Fittings~ (kg)	Calandria Tubes# (kg)	Calandria Tube Inserts+ (kg)	Steam Generators (kg)
Zr	4.3E+05		1.7E+05		
Nb	1.2E+04				
Sn			1.7E+03		
Cr		1.7E+05		1.5E+03	3.8E+05
Fe		2.1E+06		1.9E+04	8.9E+06
C					1.9E+05
Mn					1.5E+05
Ni					1.6E+06
Others	1.8E+03	3.3E+04	3.4E+02	2.9E+02	2.2E+04
<b>Total</b>	<b>4.4E+05</b>	<b>2.3E+06</b>	<b>1.7E+05</b>	<b>2.1E+04</b>	<b>1.1E+07</b>

\* Based on weight of 61 kg/PT and 30 PT/box.

~ Based on weight of 163 kg/EF and 16 EF/box.

# Based on weight of 23 kg/CT and 44 CT/box.

+ Based on weight of 1.2 kg/CTI and 384 CTI/box.

### 3.4 Bulk Material Inventory

The inventory of reactor refurbishment container materials, in terms of mass of metal and concrete associated with the containers, and total surface area based on “Scenario B” at 2052 is summarized in Table 3.5. The inventory is based on the weight of steel and concrete in each container. The surface areas are calculated based on container dimensions provided in Appendix E. The stainless steel surface area totals for retube waste containers include the internal surface area as the boxes are of steel-concrete-steel construction. The total mass of concrete includes the grout that will be used to fill the steam generators. The Inconel 600 inventory is attributed to the tube weight inside of the steam generators.

The total estimated inventory of steel in container materials (including the rebar in concrete shielding) and the steam generator shell is  $1.7 \times 10^7$  kg. The total weight of concrete is estimated to be  $3.2 \times 10^7$  kg.

Report

<b>OPG Proprietary</b>		
Document Number: <b>00216-REP-03902-00003</b>	Usage Classification: <b>INFORMATION</b>	
Sheet Number: <b>N/A</b>	Revision Number: <b>R003</b>	Page: <b>35 of 136</b>

Title:  
**REFERENCE LOW- AND INTERMEDIATE-LEVEL WASTE INVENTORY FOR THE DEEP GEOLOGIC REPOSITORY**

Table 3.5: Inventory of Reactor Refurbishment Container Materials

Container Type	Number of Containers/ Items	Total Mass* (kg)				Total Surface Area* (m <sup>2</sup> )					
		Carbon Steel	Stainless Steel	Inconel 600	Concrete	Carbon Steel (rebar in container)	Carbon Steel <sup>^</sup>	Stainless Steel (External)	Stainless Steel (Internal)	Inconel 600 <sup>+</sup>	Concrete (External)
Retube Waste Container (PT) – Pressure Tubes	242		1.1E+06		5.2E+06	1.3E+05		5.7E+03	2.8E+03		5.7E+03
Retube Waste Container (PT) – Calandria Tubes	167		7.5E+05		3.6E+06	8.9E+04		3.9E+03	2.0E+03		3.9E+03
Retube Waste Container (PT) – Calandria Tube Inserts	45		2.0E+05		9.7E+05	2.4E+04		1.1E+03	5.3E+02		1.1E+03
Retube Waste Container (EF) – End Fittings	899		5.8E+06		2.0E+07	5.3E+05		2.1E+04	1.1E+04		2.1E+04
Steam Generator (Bruce A)	32	2.1E+06		6.9E+05	4.9E+05		3.1E+03			7.6E+04	
Steam Generator (Bruce B)	32	3.3E+06		1.1E+06	7.5E+05		4.2E+03			7.7E+04	
Steam Generator (Pickering)	48	3.1E+06		1.0E+06	7.1E+05		4.1E+03			8.8E+04	
<b>TOTAL</b>	<b>1465</b>	<b>8.4E+06</b>	<b>7.8E+06</b>	<b>2.8E+06</b>	<b>3.2E+07</b>	<b>7.7E+05</b>	<b>1.1E+04</b>	<b>3.2E+04</b>	<b>1.6E+04</b>	<b>2.4E+05</b>	<b>3.2E+04</b>

Note: Unless otherwise documented, surface areas cover outside areas only.

\* Container only.

<sup>^</sup> Surface area for steam generator shell.

<sup>+</sup> Surface area for steam generator tubes.

OPG Proprietary		
Document Number:	00216-REP-03902-00003	Usage Classification: <b>INFORMATION</b>
Sheet Number:	Revision Number: R003	Page: 36 of 136

Title:

## REFERENCE LOW- AND INTERMEDIATE-LEVEL WASTE INVENTORY FOR THE DEEP GEOLOGIC REPOSITORY

### 4.0 TOTAL OPERATIONAL AND REFURBISHMENT LOW- AND INTERMEDIATE-LEVEL WASTE INVENTORY

This section provides a summary of the waste volume and radiological inventory data presented in sections 2 and 3. The projected inventories are based on historical waste production rates, expected impact of waste minimization initiatives, and current plans to bring laid-up reactor units back to service ("Scenario B").

#### 4.1 Total Low- and Intermediate-Level Waste Volume

Approximately 170,000 m<sup>3</sup> of stored volume (after processing by compaction and incineration as applicable and recovery of space occupied by backlogged wastes) of operational L&ILW and reactor refurbishment waste is expected to be generated from the committed nuclear program. Table 4.1 provides a summary of stored waste volumes for the major container groups. The projected volumes by waste type are depicted in Figures 4.1 - 4.3. The totals by this calculation are a little less than the stored volume reported by container type because of items such as filters, IX columns, and core components, which occupy a volume less than the liners and shields in which they are stored or projected to be stored in.

**Table 4.1: Scenario B Forecast Container Stored Volume**

Container Group	Stored Volume (m <sup>3</sup> )
Boxed LLW	131,579
Boxed ILW*	5,464
Resin Liners	7,341
Tile Holes, Tile Hole Liners, T-H-E Liners, and ETHs	1,468
Heat Exchangers & Steam Generators	11,162
Retube Waste Containers	13,298
<b>Total</b>	<b>170,312</b>

\* Comprised of shield plug containers and ILW shields.

Table 4.2 summarizes the forecast L&ILW package inventory for disposal as it would arrive at the receiving area of the DGR. The table also documents the expected range of package sizes and weights.

Based on the container projections from Table 2.1 (operational L&ILW) and Table 3.1 (refurbishment L&ILW), then approximately 53,000 packages representing an emplaced volume of about 200,000 m<sup>3</sup> will be sent to the DGR. This volume could be reduced by the incineration of compact bales if incineration capacity permits. Further reduction of the total volume may be possible through sorting and processing of the currently deemed "non-processible" portion of the waste, future adoption of advanced processing techniques or aggressive station waste minimization programs.

After 2018, it is assumed that IC-18 T-H-E wastes will be packaged in ILW shields. Large component wastes, such as heat exchangers and steam generators, are



**Report**

<b>OPG Proprietary</b>		
Document Number:	<b>00216-REP-03902-00003</b>	Usage Classification:
		<b>INFORMATION</b>
Sheet Number:	Revision Number:	Page:
<b>N/A</b>	<b>R003</b>	<b>37 of 136</b>

Title:

**REFERENCE LOW- AND INTERMEDIATE-LEVEL WASTE INVENTORY FOR THE DEEP GEOLOGIC REPOSITORY**

assumed to be low-level wastes for disposal purposes. However, in the future, some opportunities may be found to decontaminate and scrap some items. The remaining items would be size-reduced to pieces that meet physical constraints and/or weight limits of the repository material handling systems.

As part of reactor lifecycle management activities, some or all of the feeder pipes may require replacement. The current assumption is that replaced feeders will be cut into suitable lengths and packaged in non-processible waste containers. The packaged volume of feeder pipes is included in the non-processible waste totals.

Appendix E provides a description of each of the various DGR container and overpack types. There are currently in excess of 100 different waste containers that have been used for storage of L&ILW at the WWMF. For the purposes of this report, containers of similar design have been grouped and only containers typical of those found in each group have been listed. The individual container datasheets provide a description of the container including a picture and drawing, and physical, chemical, and radiological properties of the wastefrom. The datasheets provide forecast package and waste inventories for "Scenario B" (the reactor life extension scenario) at 2018, and 2052.

<b>OPG Proprietary</b>		
Document Number: <b>00216-REP-03902-00003</b>		Usage Classification: <b>INFORMATION</b>
Sheet Number: <b>N/A</b>	Revision Number: <b>R003</b>	Page: <b>38 of 136</b>

Title:

**REFERENCE LOW- AND INTERMEDIATE-LEVEL WASTE INVENTORY FOR THE DEEP GEOLOGIC REPOSITORY**

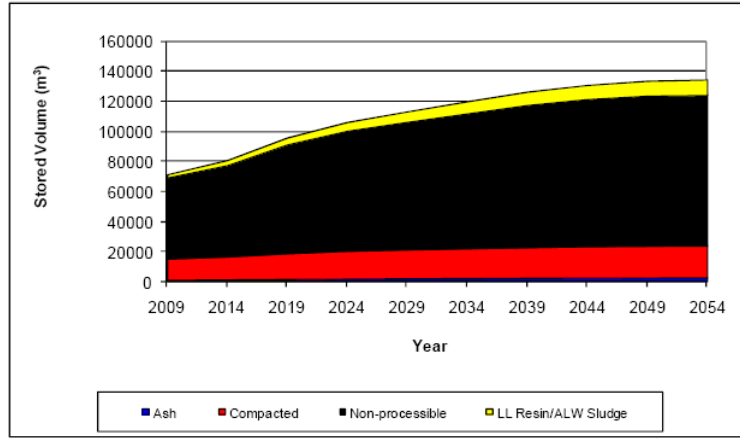

**Figure 4.1: Annual Operational Low-Level Waste Production Forecast**

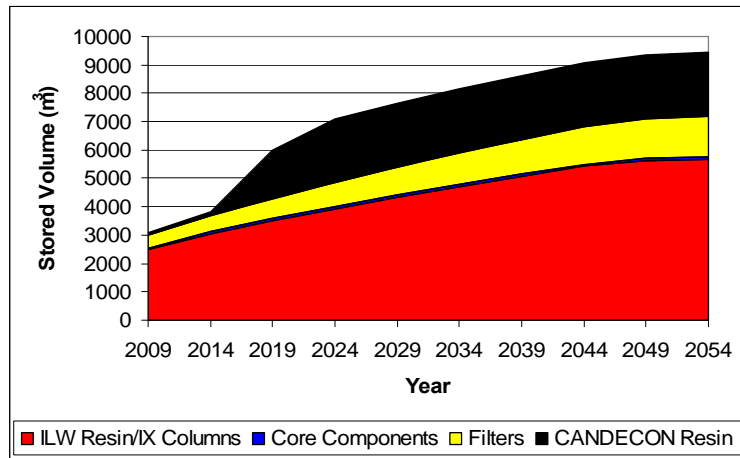

**Figure 4.2: Annual Operational Intermediate-Level Waste Production Forecast**

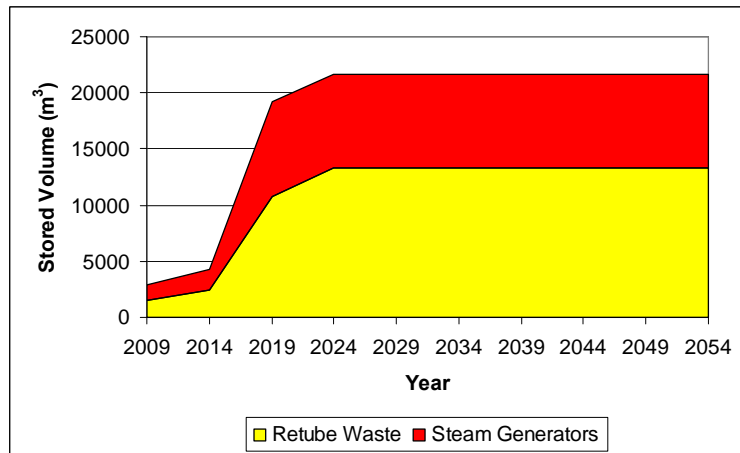

**Figure 4.3: Annual Reactor Refurbishment Waste Production Forecast**

Report

OPG Proprietary		
Document Number:	00216-REP-03902-00003	Usage Classification: <b>INFORMATION</b>
Sheet Number:	Revision Number: R003	Page: 39 of 136

Title:

**REFERENCE LOW- AND INTERMEDIATE-LEVEL WASTE INVENTORY FOR THE DEEP GEOLOGIC REPOSITORY**

**Table 4.2: Operational and Refurbishment Low- and Intermediate-Level Waste Package Inventory for Deep Geologic Repository**

Container Type	Number of Containers	Emplaced Volume (m <sup>3</sup> )	Dimensions LxWxH (m)	Empty Mass (kg)	Avg. Full Mass (kg)	Comments
<b>LLW Packages</b>						
Bale Racks	1,383	4,702	2.29 x 1.22 x 1.2	150	1,400	-
Compactor Boxes	6,135	17,177	1.84 x 1.12 x 1.3	486	2,722	-
Non-pro Bins	24,164	73,483	1.96 x 1.32 x 1.19	360	1,460	Volume/mass based on NPB47 container.
Drum Racks	2,903	9,870	2.29 x 1.22 x 1.2	150	1,490	6 drums per Rack.
Drum Bins	4,615	12,922	1.96 x 1.32 x 1.03	290	1,450	6 drums per Bin.
LL Resin Pallet Tanks	2,085	5,627	1.24 x 1.24 x 1.68	320	2,000	No overpack.
LLW Container Overpacks	3,212	27,303	2.54 x 1.78 x 1.88	1,591	max 5,400	Overpacking for 1,100 ash bins, 80 LL resin boxes, 1,709 ALW sludge boxes, and 323 drum racks.
Shield Plug Containers	26	309	3.0 x 1.8 x 1.8	13,000	26,000	Non-pro waste.
Heat Exchangers	98	2,775	Various e.g., 2 OD x 4.6 OL	n/a	10,000-30,000	Assume 25% of 98 heat exchangers will be segmented in half.
Encapsulated Tile Holes	66	504	1.5 (OD) x 4.6 (OL)	n/a	25,000	-
Steam Generator Segments	512	8,387	1.8-3.6 (OD) x 2.0-4.3 (OL)	n/a	25,730	Without grout
<b>ILW Packages</b>						
Resin Liners - Unshielded	286	858	1.63 (OD) x 1.8 (OL)	795	4,545	Without sacrificial pallet.
Resin Liner Overpacks - Unshielded	400	1,640	1.68 (OD) x 1.91 (OL)	1,450	6,000	Without sacrificial pallet.
Resin Liner 250 mm Shield	646	10,467	2.2 (OD) x 4.25 (OL)	17,760	26,850	Two resin liners per shield.
Resin Liner 350 mm Shield	164	3,295	2.4 (OD) x 4.45 (OL)	27,060	36,150	Two resin liners per shield.
Resin Liner 350 mm Shield with Steel Insert	140	1,925	2.53 (OD) x 2.74 (OL)	24,420	28,965	One resin liner per shield.
ATHEL Waste Package 350 mm Shield	300	4,140	2.53 (OD) x 2.74 (OL)	20,900	23,500	One ATHEL package per shield.
Tile Hole Liners	201	176	0.61 (OD) x 3.4 (OL)	450	2,000	Without shield.
Retube Waste Containers	1,353	13,298	1.70 x 3.35 x 1.92	29,200	33,500	Volume/mass based on Bruce A RWC-EF containers.
ILW Shield	3,952	5,137	1.0 (OD) x 1.7 (OL)	2,015	2,290	Replaces T-H-E Liners.
<b>Total</b>	<b>52,641</b>	<b>203,995</b>	-	-	-	

## Report

OPG Proprietary		
Document Number:	00216-REP-03902-00003	Usage Classification: <b>INFORMATION</b>
Sheet Number:	Revision Number: <b>R003</b>	Page: <b>40 of 136</b>

Title:

### **REFERENCE LOW- AND INTERMEDIATE-LEVEL WASTE INVENTORY FOR THE DEEP GEOLOGIC REPOSITORY**

#### **4.2 Total Radioactivity**

Figures 4.4 and 4.5 show the total radioactivity of operational L&ILW and refurbishment wastes in storage at WWMF or in the DGR. The decayed inventories were calculated by summing up the incremental increase in radionuclide inventory on an annual basis, and decay correcting for each year. As depicted, the decay of the activity in operational ILW at long times is controlled by the presence of C-14 in ILW resins. In LLW, the dramatic decline in the inventory is due to decay of H-3. For refurbishment wastes, the initial peaks are due to Fe-55 and Co-60.

The projected radioactivity, and stored volumes documented in the previous section were calculated using the L&ILW waste volume and characterization data contained in OPG's Integrated Waste Tracking System [Anderson et al, 2005]. The application was developed to integrate, store, and track the waste inventory and characterisation data. The database was installed, commissioned, and placed into production status in 2004.

Table 4.3 is a summary of dose rates associated with the major operational L&ILW types. The data are obtained from dose measurements at the surface of the various L&ILW storage containers as received at the WWMF. Containers that exceed the DGR dose rate limits may be placed into shielded packages for transfer to DGR.

In 2007, OPG successfully completed a project to retrieve and overpack 400 of the oldest carbon steel resin liners in ICs and trenches. Table 4.4 provides a summary of measured dose rates of resin liners as originally received and as measured during the course of the remediation work. This comparison shows the extent of radioactive decay during storage at WWMF.

Using the 2062 radionuclide inventory as a basis, the thermal power output from the DGR is estimated to be approximately 2 kW at repository closure. The primary heat sources are Co-60, Nb-94 and Sr-90/Y-90.

OPG Proprietary		
Document Number:	00216-REP-03902-00003	Usage Classification: <b>INFORMATION</b>
Sheet Number:	N/A	Revision Number: <b>R003</b>
		Page: <b>41 of 136</b>

Title:

**REFERENCE LOW- AND INTERMEDIATE-LEVEL WASTE INVENTORY FOR THE DEEP GEOLOGIC REPOSITORY**

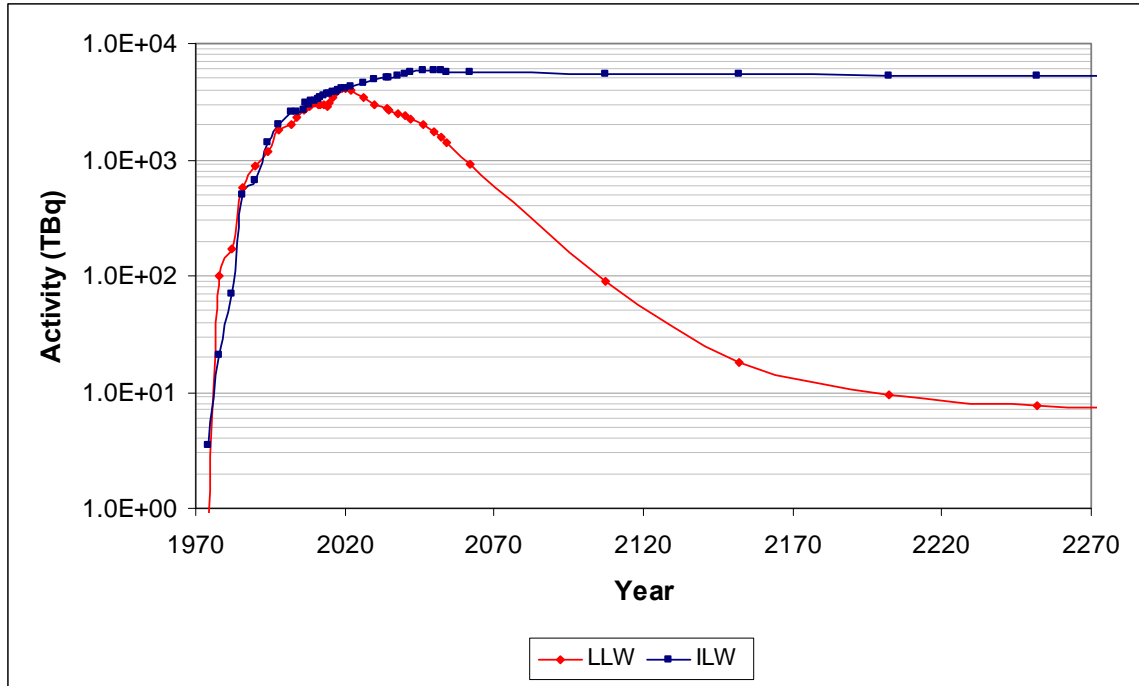

Figure 4.4: Decay Corrected Activity for Operational Low- and Intermediate-Level Waste

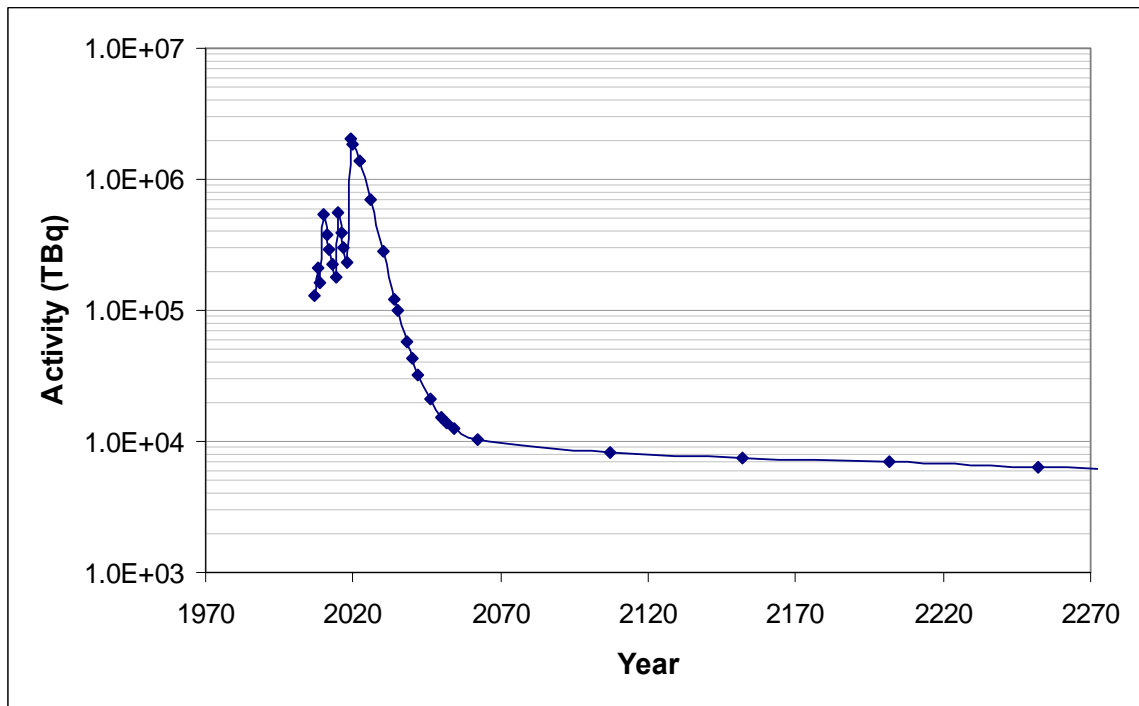

Figure 4.5: Decay Corrected Activity for Refurbishment Low- and Intermediate-Level Waste

Report

<b>OPG Proprietary</b>		
Document Number:	<b>00216-REP-03902-00003</b>	Usage Classification: <b>INFORMATION</b>
Sheet Number:	<b>N/A</b>	Revision Number: <b>R003</b>
		Page: <b>42 of 136</b>

Title: **REFERENCE LOW- AND INTERMEDIATE-LEVEL WASTE INVENTORY FOR THE DEEP GEOLOGIC REPOSITORY**

**Table 4.3: Summary of Waste Volume Fraction Handled by Waste Type and Dose Rate (As-received at Western Waste Management Facility)**

Contact Dose Rate (mSv/hr)	As-Received Volume (m <sup>3</sup> )	Overall LLW and ILW %	LLW								ILW						
			TOTAL LLW %	Ash %	Bales %	Box Comp %	Incin %	Non-pro %	Non-pro Drum %	LL/ALW Resin* %	TOTAL ILW %	CANDECON Resin %	ILW Resin %	Tile Hole Liners %	IX Column %	Filter %	Misc ILW %
< 0.01	209,754	76.2%	77.2%	9.5%	24.7%	57.9%	91.1%	64.1%	70.8%	86.2%	5.6%	2.4%	7.0%	2.9%	2.7%	1.7%	0.0%
0.01 - 0.05	28,830	10.5%	10.8%	5.6%	25.4%	26.8%	5.9%	15.5%	13.8%	13.8%	0.9%	0.0%	0.8%	0.8%	3.1%	1.2%	0.0%
0.05 - 0.1	10,997	4.0%	4.1%	14.7%	12.7%	8.8%	1.4%	6.9%	4.9%	0.0%	3.0%	7.1%	3.5%	0.0%	1.6%	1.1%	0.0%
0.1 - 0.2	6,397	2.3%	2.3%	25.4%	9.7%	3.4%	0.7%	3.7%	2.4%	0.0%	2.1%	0.0%	2.6%	0.0%	1.2%	1.5%	0.0%
0.2 - 0.5	6,770	2.5%	2.5%	38.1%	11.6%	1.7%	0.5%	4.5%	2.2%	0.0%	5.0%	4.8%	6.1%	0.0%	4.5%	2.8%	0.0%
0.5 - 1	3,338	1.2%	1.2%	5.0%	7.5%	0.8%	0.2%	2.0%	1.6%	0.0%	4.3%	0.0%	4.5%	4.4%	4.2%	6.0%	0.0%
1 - 2	2,391	0.9%	0.8%	1.3%	4.9%	0.5%	0.3%	1.2%	1.0%	0.0%	3.7%	0.0%	3.6%	4.1%	3.9%	7.1%	0.0%
2 - 10	3,380	1.2%	0.98%	0.4%	3.1%	0.1%	0.0%	1.9%	2.9%	0.0%	22.6%	23.8%	21.4%	57.2%	15.8%	22.9%	0.0%
10 - 50	1,369	0.5%	0.11%	0.0%	0.4%	0.0%	0.0%	0.2%	0.4%	0.0%	28.5%	35.7%	31.4%	19.2%	18.7%	21.0%	18.3%
50 - 100	548	0.2%	0.0%	0.0%	0.0%	0.0%	0.0%	0.0%	0.0%	0.0%	13.7%	23.8%	13.4%	5.8%	12.2%	13.5%	24.4%
100 - 500	349	0.13%	0.0%	0.0%	0.0%	0.0%	0.0%	0.0%	0.0%	0.0%	8.2%	2.4%	4.9%	5.6%	21.7%	16.4%	37.2%
500 - 1000	51	0.02%	0.0%	0.0%	0.0%	0.0%	0.0%	0.0%	0.0%	0.0%	1.4%	0.0%	0.7%	0.0%	7.1%	3.5%	3.3%
1000 - 5000	22	0.01%	0.0%	0.0%	0.0%	0.0%	0.0%	0.0%	0.0%	0.0%	0.6%	0.0%	0.1%	0.0%	3.1%	1.3%	5.7%
> 5000	985	0.36%	0.0%	0.0%	0.0%	0.0%	0.0%	0.0%	0.0%	0.0%	0.4%	0.0%	0.0%	0.0%	0.2%	0.0%	11.1%
Max. Dose Rate (mSv/hr)				5	40	3	4	30	90	.03		200	1600	300	8000	5000	700000

**Note:** Data is for wastes received at WWMF up to December 2005.  
 \* Includes LL Resin, ALW Resin, ALW Sludge.  
 ~ All other ILW e.g., core components.

Report

<b>OPG Proprietary</b>		
Document Number: <b>00216-REP-03902-00003</b>		Usage Classification: <b>INFORMATION</b>
Sheet Number: <b>N/A</b>	Revision Number: <b>R003</b>	Page: <b>43 of 136</b>

Title:

**REFERENCE LOW- AND INTERMEDIATE-LEVEL WASTE INVENTORY FOR THE DEEP GEOLOGIC REPOSITORY**

Table 4.4: Resin Liner Dose Rates “As Received” and After Decay

Dose Rate (mSv/hr)	“As-Received”* (%)	Sept-Nov 2007** (%)
< 0.01	7.0	2.8
0.01-0.1	4.3	10.4
0.1-0.2	2.6	9.8
0.2-0.5	6.1	7.0
0.5-1	4.5	4.4
1-2	3.6	7.9
2-10	21.4	56.0
>10	50.5	1.6

\* As measured at contact when originally received at WWMF.

\*\* As measured at 30 cm during resin liner retrieval program in 2007 at WWMF.

## Report

OPG Proprietary		
Document Number:	00216-REP-03902-00003	Usage Classification: <b>INFORMATION</b>
Sheet Number:	Revision Number: R003	Page: 44 of 136

Title:

### REFERENCE LOW- AND INTERMEDIATE-LEVEL WASTE INVENTORY FOR THE DEEP GEOLOGIC REPOSITORY

## 5.0 CONCLUSION

This report has presented the reference inventory and container characteristics for emplacement of operational L&ILW and refurbishment waste into the proposed DGR near the WWMF at the Bruce nuclear site. The forecasts are based on “Scenario B” which assumes refurbishment of all reactor units except Pickering A, with operation for a further 30 years after refurbishment. This scenario has the highest volume of waste among those presently considered for the current OPG nuclear program. Based on the currently stored waste and the Scenario B forecast, the following are some highlights regarding the characteristics of the L&ILW emplaced within the DGR:

- The projected total stored volume is approximately 170,000 m<sup>3</sup>.
- The projected emplaced volume of operational L&ILW and reactor refurbishment waste is approx. 200,000 m<sup>3</sup> in 53,000 packages.
- About 84% of the emplaced volume is LLW. Approximately half of the volume and number of packages to be handled are “non-processible” low-level waste.
- The total mass of waste and containers emplaced in the DGR will be approximately 50% metals, 25% organic materials, and 25% concrete.
- The total operational L&ILW radionuclide inventory is estimated to be 6.6x10<sup>15</sup> Bq at 2062 (assumed repository closure), attributed mostly to H-3 and C-14. The total refurbishment L&ILW radionuclide inventory is estimated to be 1.0x10<sup>16</sup> Bq at 2062, attributed mostly to C-14, Co-60, Ni-63 and Nb-94.
- Total thermal decay power is estimated to be 2 kW at repository closure, most of which is attributed to retube waste containers.



## Report

OPG Proprietary		
Document Number:	00216-REP-03902-00003	Usage Classification: <b>INFORMATION</b>
Sheet Number:	Revision Number: <b>R003</b>	Page: <b>45 of 136</b>

Title:

### **REFERENCE LOW- AND INTERMEDIATE-LEVEL WASTE INVENTORY FOR THE DEEP GEOLOGIC REPOSITORY**

## **6.0 ACKNOWLEDGEMENTS**

The primary author of this report was Fred Rodrigues, OPG. We also acknowledge the following for their contribution:

- Aamir Husain, Christina Wu, John Krasznai, and the support staff at Kinectrics for their invaluable contribution to NWMD's L&ILW characterization program.
- DNGS staff (Peggy Ancker, Khalil Nawar, Kwabena Shange, Tim Handley, Gerry O'Donnell, Kevin Terry, and others), for the Darlington waste samples.
- Norman Brown, for supplying the Pickering waste samples.
- Bruce Power staff (Hilary Johnson, Kurt Wigle, Bob Bisson, and others), for the Bruce Power waste samples.
- Eric Przybylowski, for coordinating the waste sampling activities at the WWMF.
- Paul Gierszewski, Kelly Sedor, and Mike Garamszeghy at NWMO for input into and review of this report.
- Robert Anderson and Cody Permann of INL, for their support of the Integrated Waste Tracking System.

OPG Proprietary		
Document Number:	00216-REP-03902-00003	Usage Classification: <b>INFORMATION</b>
Sheet Number:	Revision Number: <b>R003</b>	Page: <b>46 of 136</b>

Title:

<b>REFERENCE LOW- AND INTERMEDIATE-LEVEL WASTE INVENTORY FOR THE DEEP GEOLOGIC REPOSITORY</b>
---

## 7.0 REFERENCES

- [R-1] Anderson, R.S., M. Garamszeghy, F. Rodrigues and E. Nicholls. 2005. Installing and Commissioning a New Radioactive Waste Tracking System – Lesson Learned. Proceedings, CNS Waste Management Conference. Ottawa, Canada.
- [R-2] Aydogdu, K.M., C.R. Boss and D.W. McKean. 1989. Comparison of measured and calculated dose rates and activities during pressure tube replacement in Pickering Units 1 and 2. Proceedings CNS 10th Annual Conference, p.4-36. Ottawa, Canada.
- [R-3] CH2MHILL, 2006. WWMF Refurbishment Waste Storage Project – Processing of Steam Generators. Prepared for OPG.
- [R-4] Hermann, O. and R. Westfall, 1995. ORIGEN-S – SCALE system module to calculate fuel depletion, actinide transmutation, fission product buildup and decay, and associated radiation source terms in SCALE: A modular code system for performing standardized computer analyses for licensing evaluations. NUREG/CG-0200, Rev.4 (ORNL/NUREG/CSD-2/R4), Vol. II, Part I. Oak Ridge, USA.
- [R-5] Husain, A. 2005a. Characterization of Ontario Power Generation's Spent Resins. Proceedings, CNS Waste Management Conference. Ottawa, Canada.
- [R-6] Husain, A. 2005b. Characterization of Ontario Power Generation's Low- and Intermediate-Level Reactor Waste – An Overview. Proceedings, CNS Waste Management Conference. Ottawa, Canada.
- [R-7] ISO. 2007. The Scaling Factor Method to determine the Radioactivity of Low- and Intermediate-Level Radioactive Waste Packages generated a Nuclear Power Plants. International Standards Organisation, ISO 21238-2007. Geneva, Switzerland.
- [R-8] IAEA. 2009. Determination and Use of Scaling Factors for Waste Characterization in Nuclear Power Plants. IAEA report NW-T-1.18. Vienna, Austria.
- [R-9] Lewis, B. and A. Husain. 2003. Modelling the Activity of I-129 in the Primary Coolant of a CANDU Reactor. Journal of Nuclear Materials 312, pp. 81-96.
- [R-10] Lewis, B., W.T. Thompson and A. Husain, 2003. Modelling the Activity of Tc-99 in the Primary Heat Transport System of a CANDU Reactor. Proc. 85<sup>th</sup> Inter. Conf. on CANDU Fuel, Honey Harbour, Canada.
- [R-11] Pearson, S., M. Lewis and A. Husain. 2008. Resin Liner Recovery and Overpacking at OPG's Western Waste Management Facility. Proceedings, Waste Management 2008. Phoenix, USA.

**Report**

<b>OPG Proprietary</b>		
Document Number:	<b>00216-REP-03902-00003</b>	Usage Classification: <b>INFORMATION</b>
Sheet Number:	<b>N/A</b>	Revision Number: <b>R003</b>
		Page: <b>47 of 136</b>

Title:

**REFERENCE LOW- AND INTERMEDIATE-LEVEL WASTE INVENTORY FOR THE DEEP GEOLOGIC REPOSITORY**

- [R-12] Tait, J.C., H. Roman and C.A. Morrison. 2000. Characteristics and Radionuclide Inventories of Used Fuel from OPG Nuclear Generating Stations, Volumes 1 and 2. Ontario Power Generation Report 06819-REP-01200-10029-R00. Toronto, Canada.

OPG Proprietary		
Document Number:	00216-REP-03902-00003	Usage Classification: <b>INFORMATION</b>
Sheet Number:	Revision Number: R003	Page: 48 of 136

Title:

## REFERENCE LOW- AND INTERMEDIATE-LEVEL WASTE INVENTORY FOR THE DEEP GEOLOGIC REPOSITORY

### Appendix A: Technical Assumptions

#### A.1.0 GENERAL ASSUMPTIONS

- (i) Forecasts include all L&ILW generated by the operation of OPG's nuclear reactors at Pickering, Bruce (now operated by Bruce Power), and Darlington and related facilities.
- (ii) Pickering A Units 1 and 4, Pickering B, Bruce B, and Darlington continue to operate. Pickering A Units 2 and 3 will not be returned to service. Bruce A Units 3 and 4 were restarted in 2003. Bruce A Units 1 and 2 are assumed to be refurbished and restarted in 2009 and 2010.
- (iii) Radioactive liquids, and decommissioning wastes are specifically excluded from the inventory. Radioactive liquids are assumed to be incinerated or solidified, and the resulting volume of secondary waste is included in the inventory.
- (iv) The waste generation and processing scenario(s) are based on Corporate and/or Divisional reference plans for number of operating units, and Waste Volume Reduction Building equipment life, enhancement, and/or replacement where available or applicable.
- (v) Current volume reduction capacities are maintained as a minimum including incineration; Low Level Storage Building resorting, reprocessing and re-storing programs are maintained; continued processing of contaminated oil, and completion of RWOS#1 waste removal are assumed.

#### A.2.0 WASTE GENERATION SCENARIOS

Two scenarios for end-of-life dates are outlined in Table A.1. "Scenario A" is an OPG Financial Reference Plan which excludes refurbishment and life extension of reactors except for Bruce A Units 1, 2, 3 and 4, while "Scenario B" considers refurbishment of all reactor units (except Pickering A) with operation for a further 30 calendar years after refurbishment. The decision to refurbish reactors will be made at an appropriate time in the future on a unit-by-unit basis. Waste generation from potential new-build reactors in Ontario is not included in this scenario.

The detailed assumptions for operational L&ILW and reactor refurbishment waste are:

- (i) Stations produce no operational wastes after shutdown of the last unit. Any waste produced post shutdown is considered to be decommissioning waste.
- (ii) The reactor operational LLW, following various minimization initiatives, will be generated at a rate of about 200 m<sup>3</sup> produced per reactor unit per year. The annual volumes of operational waste produced will reduce proportionately as the various units are permanently shutdown.

## Report

OPG Proprietary		
Document Number:	00216-REP-03902-00003	Usage Classification: <b>INFORMATION</b>
Sheet Number:	Revision Number: <b>R003</b>	Page: <b>49 of 136</b>

Title:

### **REFERENCE LOW- AND INTERMEDIATE-LEVEL WASTE INVENTORY FOR THE DEEP GEOLOGIC REPOSITORY**

- (iii) Non-processible, compactable, and incinerable components of LLW generally remain constant at 20%, 16% and 64%. Based on the waste received during the retubing of Pickering units in 1983-93, this ratio changes during the years that reactor retubing activities are being conducted to 33%, 10% and 57% for the units being retubed.
- (iv) Reactor refurbishment is expected to produce an extra 500 m<sup>3</sup>/unit/yr of LLW during the years that refurbishment is carried out.
- (v) 40 m<sup>3</sup> of contaminated oil are received each year at the WWMF. Contaminated oil (including accumulated backlog) is incinerated.
- (vi) Resin volumes (ILW) vary as a result of station resin consumption, including periodic CANDECON (and/or CANDEREM) campaigns, and the draw-down of station resin tanks. For the purpose of system planning, station resin tanks are assumed to remain at their December 2007 levels. Station tanks will be emptied and transferred to the WWMF in the year following station shutdown (Bruce stations where common tanks serve 4 units) or unit shutdown (Pickering and Darlington stations, where each unit has its own storage tank[s]). WWMF resin receipts will be based on historic average station resin production. Future CANDECON/CANDEREM campaigns are expected to occur only in conjunction with reactor retubing operations.
- (vii) Filters and IX columns (ILW) are received at the WWMF at a yearly rate equal to the historic average actual volumes received in past years. This is equivalent to the average station production levels (i.e., waste is shipped from the station as it is produced).
- (viii) Total ILW is produced at an annual rate of 50 m<sup>3</sup>/year total per 4 unit Darlington station; 37m<sup>3</sup>/yr for 4 unit Bruce A or B station, and 67 m<sup>3</sup>/yr for 6 unit Pickering A/B and then reduced consistent with station shutdowns, as in the case of LLW. The amount of ILW received at the WWMF will vary as per (vi).
- (ix) Bruce A, Bruce B, Pickering B and Darlington are retubed (Pickering A was previously retubed in the 1980s/1990s). The assumed schedule is given in Table A.1, based on Pickering A style "large scale fuel channel replacement".
- (x) Bruce B CANDECON resin is stored in IC-18s (240 m<sup>3</sup> per reactor stored volume). No CANDECON is planned prior to the Bruce A retube.
- (xi) Pickering (55 m<sup>3</sup> per reactor stored volume) and Darlington (240 m<sup>3</sup> per reactor stored volume) CANDECON resin will be shipped to the WWMF for storage in IC-18s.
- (xii) Steam generators are assumed to be replaced in Bruce A, Bruce B and Pickering B. No steam generator replacement is considered in these lifecycle plans for Pickering A or Darlington.

OPG Proprietary		
Document Number:	00216-REP-03902-00003	Usage Classification: <b>INFORMATION</b>
Sheet Number:	Revision Number: <b>R003</b>	Page: <b>50 of 136</b>

Title:

**REFERENCE LOW- AND INTERMEDIATE-LEVEL WASTE INVENTORY FOR THE DEEP GEOLOGIC REPOSITORY**

Figure A.1: Forecasting Scenarios

Unit	Scenario A*			Scenario B*		
	Retubing	SG Replacement	End-of-life	Retubing	SG Replacement	End-of-life
Pickering A1	-	-	2021	-	-	2021
Pickering A2	-	-	2005	-	-	2005
Pickering A3	-	-	2005	-	-	2005
Pickering A4	-	-	2021	-	-	2027
Pickering B5	-	-	2013	2016-18	2016-18	2045
Pickering B6	-	-	2013	2017-20	2017-20	2046
Pickering B7	-	-	2014	2019-21	2019-21	2048
Pickering B8	-	-	2015	2021-23	2021-23	2049
Bruce A1**	2007-09	2007-09	2034	2007-09	2007-09	2034
Bruce A2**	2006-08	2006-08	2034	2006-08	2006-08	2034
Bruce A3**	2010-11	2010-11	2036	2010-11	2010-11	2036
Bruce A4**	2015-16	2015-16	2037	2015-16	2015-16	2037
Bruce B5**	-	-	2014	2017-18	2017-18	2043
Bruce B6**	-	-	2014	2016-17	2016-17	2042
Bruce B7**	-	-	2014	2018-19	2018-19	2044
Bruce B8**	-	-	2014	2019-20	2019-20	2045
Darlington 1	-	-	2018	2016-18		2050
Darlington 2	-	-	2019	2018-20		2048
Darlington 3	-	-	2019	2020-22		2051
Darlington 4	-	-	2020	2022-24		2053

\* Conservative dates for long-term waste management planning purposes only. May differ from station lifecycle plans.

\*\* Subject to Bruce Power operating plans.

### A.3.0 WASTE PROCESSING SCENARIOS

- (i) Current volume reduction capacities are maintained, as a minimum, including incineration and compaction as well as continued processing of contaminated oil. Future programs may include LLSB resorting, reprocessing and re-storing and completion of RWOS #1 waste removal.
- (ii) Annual incineration capability of at least 1,750 m<sup>3</sup> in 2009; 2,000 m<sup>3</sup> in 2010 and 2011; 2,250 m<sup>3</sup> in 2012; and 2,500 m<sup>3</sup> onwards at a volume reduction factor of 40:1, with the remainder of the processible LLW being compacted with a volume reduction factor of 4:1. The non-processible portion of the waste is packaged and stored, with a net volume increase of 0.75:1.
- (iii) Incineration of oils started in 2003, with a net volume reduction factor of 100:1. The limit for oil incineration is included in the overall incinerator licensed limit of 2,272 kg/day. (The average processing rate for oils is assumed to be 80 m<sup>3</sup>/yr.)

## Report

OPG Proprietary		
Document Number:	00216-REP-03902-00003	Usage Classification: <b>INFORMATION</b>
Sheet Number:	Revision Number: <b>R003</b>	Page: <b>51 of 136</b>

Title:

### REFERENCE LOW- AND INTERMEDIATE-LEVEL WASTE INVENTORY FOR THE DEEP GEOLOGIC REPOSITORY

- (iv) The effects of possible future installation of advanced waste processing equipment that may further reduce stored and disposed volumes are not considered.
- (v) During the 2001-2002 WVRB incinerator replacement outage, compactable and incinerable wastes were backlogged without processing (approx 5,500 m<sup>3</sup>). During 2004, much of this waste was processed by compaction. It is assumed that any remaining backlogged wastes will also be processed. Other processible wastes previously backlogged (e.g., baled waste ~5,000 m<sup>3</sup> and oil ~600 m<sup>3</sup>) will also be recovered and incinerated in the future when available incineration capacity permits.
- (vi) All ash containers, low level resin boxes, and ALW sludge boxes, and 10% of all drum racks will be packaged in LLW container overpacks.
- (vii) The Bruce irradiated component waste from retube will be packaged in "L&ILW DGR-Ready" shielded containers, and stored in an above-ground warehouse building(s) at the WWMF site. The boxes for volume reduced components (pressure tubes, calandria tubes, etc.) are approx 1.85 m x 1.85 m x 2.25 m high external dimension, with a steel-concrete-steel construction. The walls contain approx 0.5 m of heavy concrete and the loaded weight is approx 30 tonnes. The containers for un-cut end fittings are of similar construction and loaded weight, with external dimensions of 1.70 m x 3.35 m x 1.92 m high and holding 16 to 20 end fittings. Approx 30 of the pressure tube style boxes and 60 of the end fitting style boxes are required per reactor unit.
- (viii) Similar to the Bruce retubing waste, Pickering B and Darlington retubing waste is assumed to be packaged in "disposal ready" concrete boxes, stored in an above-ground warehouse building(s) at the PWMF and DWMF sites, respectively.
- (ix) Other wastes generated during reactor refurbishment, such as feeder pipes, insulation, miscellaneous hardware, etc., are packaged and handled similar to routine operational wastes.
- (x) No extra processing/packaging is required with the exception of shielding of most of the ILW and overpacking of a small portion of the LLW such as incinerator ash. The estimates of the number of containers that will require overpacking is considered conservative.

#### A.4.0 WASTE CHARACTERISATION DATA

The waste radionuclide inventory, chemical and physical characterisation data, and scaling factors for "difficult to measure" radionuclides have been developed by Kinectrics Inc. and other groups (such as the CANDU Owners Group Working Party 49) over a period of many years [Husain, 2005a, 2005b], using internationally accepted approaches [ISO 2007, IAEA 2009].

## Report

OPG Proprietary		
Document Number:	00216-REP-03902-00003	Usage Classification: <b>INFORMATION</b>
Sheet Number:	Revision Number:	Page:
N/A	R003	52 of 136

Title:

### **REFERENCE LOW- AND INTERMEDIATE-LEVEL WASTE INVENTORY FOR THE DEEP GEOLOGIC REPOSITORY**

Four types of radionuclide characterisation data have been developed:

- (a) Average measured values – This data applies mostly for “easy to measure” gamma emitting radionuclides such as Co-60 and Cs-137. They are based on direct analysis of samples of different categories of wastes, or are inferred from measured gamma dose rates.
- (b) Scaling factors – This data applies for important but “difficult to measure” radionuclides (mostly for beta emitters such as C-14, Sr-90 and some alpha emitters such as Pu-238 and Pu-239/240). They are based on values obtained from detailed radiochemical analyses of waste samples for the radionuclide of interest and comparing it to “easy to measure” radionuclides. The ratio of the “difficult to measure” to the “easy to measure” radionuclide is used for estimating the “difficult to measure” radionuclide in wastes of a similar type, once the “easy to measure” radionuclide has been measured. In some instances, approaches based on theoretical modeling have been developed (e.g., I-129/Cs-137) to support the data obtained by experimental analysis; and
- (c) Fuel inventory ratios – This applies for radionuclides that are potentially of interest (e.g., very long-lived) but are only present at low concentrations. Fuel inventory ratios are used where waste-specific scaling factors have not been developed. They are based on the calculated abundance ratio of these nuclides compared with an easier to measure radionuclide in the used fuel. Reasonable agreement has been achieved between measured scaling factors and estimates from fuel inventory ratios for common radionuclide pairs (e.g., Pu-239/Cs-137) used in scaling factors.
- (d) Activation calculations – This applies to refurbishment and other irradiated metals where the important radionuclides tend to be generated from neutron activation. The radionuclide inventories are calculated using ORIGEN-S or similar codes.

The radionuclide inventories in this report have been calculated based on the latest recommended specific activities, scaling factors, and radionuclide ratios in used fuel for individual radionuclides and waste categories.



Report

<b>OPG Proprietary</b>		
Document Number: <b>00216-REP-03902-00003</b>	Usage Classification: <b>INFORMATION</b>	
Sheet Number: <b>N/A</b>	Revision Number: <b>R003</b>	Page: <b>53 of 136</b>

Title:  
**REFERENCE LOW- AND INTERMEDIATE-LEVEL WASTE INVENTORY FOR THE DEEP GEOLOGIC REPOSITORY**

**Appendix B: Specific Activities of Operational and Refurbishment Low- and Intermediate-Level Waste**

**Table B.1: Summary of Specific Activities of Operational Low-Level Waste (As-Received)**

Nuclide	Half Life (yrs)	Estimated Specific Activity of net waste volume (Bq/m <sup>3</sup> )											
		Bottom Ash (Old)	Baghouse Ash (Old)	Bottom Ash(New)	Baghouse Ash(New)	Compact Bales	Box Compacted	Non-pro	Feeder Pipes*	Non-pro Other	Non-pro Drummed	LL/ALW Resin	ALW Sludge
Ag-108m	1.3E+02	6.4E+02	4.9E+03	3.0E+02	2.6E+02	3.3E+02	4.0E+02	4.7E+02	1.3E+03	4.7E+02	4.7E+02	1.1E+02	7.8E+01
Am-241	4.3E+02	1.7E+05	1.6E+05	3.0E+06	2.3E+04	2.4E+05	3.0E+05	4.4E+05	9.6E+06	2.6E+04	2.4E+01	1.4E+04	5.6E+03
Am-242m	1.5E+02								1.6E+04				
Am-243	7.4E+03	3.2E+02	2.4E+02	2.3E+03	2.2E+01	3.3E+02	4.0E+02	3.3E+01	1.8E+04	3.3E+01	3.8E-02	1.9E+01	8.3E+00
Ba-133	1.1E+01							2.1E+05					
C-14	5.7E+03	8.1E+06	3.0E+06	5.6E+07	8.4E+03	5.5E+06	6.7E+06	7.3E+05	3.3E+08	7.3E+05	1.5E+07	6.3E+06	2.2E+06
Ce-144	7.8E-01								2.9E+09				
Cf-252	2.6E+00							1.1E+04					
Cl-36	3.0E+05	1.6E+02	4.1E+01	2.5E+02	1.6E+00	6.8E+01	8.3E+01	3.7E+01	1.7E+05	2.0E+01	4.4E+01	1.1E+01	5.3E+00
Cm-244	1.8E+01	4.9E+04	3.4E+04	3.8E+05	6.1E+03	1.1E+05	1.3E+05	7.9E+03	3.8E+06	7.9E+03	3.5E+00	4.1E+03	2.0E+03
Co-60	5.3E+00	1.6E+08	4.1E+07	2.5E+08	1.6E+06	6.8E+07	8.3E+07	2.0E+07	1.4E+10	2.0E+07	4.4E+07	1.1E+07	5.3E+06
Cs-134	2.1E+00	7.6E+06	5.1E+07	7.0E+05	6.7E+05	5.6E+06	6.8E+06	3.0E+05	3.4E+07	3.0E+05	2.8E+06	7.4E+04	4.5E+06
Cs-135	2.3E+06	6.3E+01	4.8E+02	2.9E+01	2.5E+01	3.2E+01	3.9E+01	4.6E+01	1.3E+02	4.6E+01	4.6E+01	1.0E+01	7.7E+00
Cs-137+ Ba-137m	3.0E+01	1.2E+08	9.4E+08	5.6E+07	5.0E+07	6.2E+07	7.6E+07	7.8E+08	2.6E+08	9.0E+07	8.8E+07	2.0E+07	1.5E+07
Eu-152	1.3E+01										4.4E+04		
Eu-154	8.8E+00	2.8E+06	2.6E+06	1.0E+06		1.9E+06	2.3E+06		5.8E+07		4.8E+04		
Eu-155	5.0E+00	6.3E+05				4.0E+05	4.9E+05						
Fe-55	2.7E+00	1.0E+09	3.0E+08	1.3E+10	9.9E+06	2.6E+06	3.2E+05	9.6E+07	4.0E+10	9.6E+07	8.4E+07	5.0E+07	1.8E+07
Fe-59	1.2E-01				5.3E+06								
Gd-153	6.6E-01				3.0E+06								
H-3	1.2E+01	2.5E+07		2.5E+07		2.3E+11	2.8E+11	3.0E+10		3.0E+10	6.1E+11	1.3E+08	3.0E+09
I-129	1.6E+07	2.1E+01	1.6E+02	9.9E+00	8.6E+00	1.1E+01	1.3E+01	1.6E+01	3.7E+01	1.6E+01	1.6E+01	3.5E+00	2.7E-02
La-140	4.6E-03	2.6E+08											
Nb-94	2.0E+04	1.4E+06		3.7E+06	4.0E+04	8.6E+05	1.0E+06				1.1E+05		4.2E+04
Nb-95	9.5E-02		1.2E+07						2.7E+09				
Ni-59	7.5E+04	1.1E+06	2.1E+04	9.7E+04	6.7E+02	5.3E+03	6.5E+03	7.5E+03	3.9E+05	7.5E+03	5.7E+03	1.8E+03	9.0E+02
Ni-63	9.6E+01	1.5E+08	3.0E+06	1.4E+07	9.4E+04	7.5E+05	9.1E+05	1.8E+06	5.5E+07	1.1E+06	8.0E+05	2.6E+05	1.3E+05
Np-237	2.1E+06	1.5E+01	1.2E+01	1.1E+02	1.0E+00	1.6E+01	1.9E+01	1.6E+00	8.8E+02	1.6E+00	1.8E-03	9.3E-01	4.0E-01
Pb-210	2.2E+01							3.0E+06					

Report

<b>OPG Proprietary</b>		
Document Number: <b>00216-REP-03902-00003</b>		Usage Classification: <b>INFORMATION</b>
Sheet Number: <b>N/A</b>	Revision Number: <b>R003</b>	Page: <b>54 of 136</b>

Title:  
**REFERENCE LOW- AND INTERMEDIATE-LEVEL WASTE INVENTORY FOR THE DEEP GEOLOGIC REPOSITORY**

Nuclide	Half Life (yrs)	Estimated Specific Activity of net waste volume (Bq/m <sup>3</sup> )											
		Bottom Ash (Old)	Baghouse Ash (Old)	Bottom Ash(New)	Baghouse Ash(New)	Compact Bales	Box Compacted	Non-pro	Feeder Pipes*	Non-pro Other	Non-pro Drummed	LL/ALW Resin	ALW Sludge
Pu-238	8.8E+01	6.4E+04	6.2E+04	7.7E+05	5.3E+03	5.0E+04	6.1E+04	5.4E+03	3.1E+06	5.4E+03	3.8E+00	3.1E+03	1.3E+03
Pu-239	2.4E+04	1.0E+05	7.7E+04	7.3E+05	6.8E+03	1.0E+05	1.3E+05	1.0E+04	5.8E+06	1.0E+04	1.2E+01	6.1E+03	2.6E+03
Pu-240	6.5E+03	1.5E+05	1.1E+05	1.0E+06	9.7E+03	1.5E+05	1.8E+05	1.5E+04	8.0E+06	1.5E+04	1.7E+01	8.7E+03	3.7E+03
Pu-241	1.4E+01	2.6E+06	4.1E+06	4.0E+07	2.9E+05	4.0E+06	4.9E+06	5.4E+05	1.3E+08	5.4E+05	5.2E+02	2.7E+05	1.2E+05
Pu-242	3.8E+05	1.5E+02	1.1E+02	1.1E+03	9.8E+00	1.5E+02	1.8E+02	1.5E+01	8.8E+03	1.5E+01	1.7E-02	8.8E+00	3.8E+00
Ra-226	1.6E+03							8.2E+04					
Ru-106	1.0E+00	3.7E+07	1.7E+07	1.6E+06	1.0E+05	5.0E+07	6.1E+07	1.0E+06	1.3E+09	1.0E+06	7.0E+05		
Sb-124	1.7E-01		2.5E+07		1.4E+06								
Sb-125	2.8E+00	1.6E+07	4.2E+07	1.1E+07	1.3E+06	1.2E+07	1.4E+07	7.8E+05	1.0E+08	7.8E+05	1.3E+06		3.0E+06
Se-79	3.8E+05	2.2E+00	1.7E+01	1.0E+00	8.9E-01	1.1E+00	1.4E+00	1.6E+00	4.4E+02	1.6E+00	1.6E+00	3.6E-01	2.7E-01
Sm-151	9.0E+01	2.1E+02	1.6E+03	9.9E+01	8.6E+01	1.1E+02	1.3E+02	1.6E+02	4.4E+02	1.6E+02	1.6E+02	3.5E+01	2.6E+01
Sn-126	2.1E+05	3.3E+02	2.5E+03	1.5E+02	1.3E+02	1.7E+02	2.1E+02	2.4E+02	6.8E+02	2.4E+02	2.4E+02	5.5E+01	4.0E+01
Sr-90+Y-90	2.9E+01	8.2E+07	8.0E+06	3.0E+07	4.2E+05	3.0E+06	3.6E+06	1.5E+07	2.4E+09	9.0E+05	1.7E+07	1.4E+06	3.8E+05
Tc-99	2.1E+05	3.3E+01	8.3E+00	5.1E+01	3.2E-01	1.4E+01	1.7E+01	5.9E+00	1.6E+04	3.9E+00	8.9E+00	2.2E+00	1.1E+00
U-232	7.2E+01								1.5E+03				
U-233	1.6E+05								2.1E+03				
U-234	2.5E+05	1.6E+02	1.2E+02	1.2E+03	1.1E+01	1.7E+02	2.0E+02	1.7E+01	9.6E+03	1.7E+01	1.9E-02	9.9E+00	4.2E+00
U-235	7.0E+08	2.7E+00	2.0E+00	1.9E+01	1.8E-01	2.7E+00	3.3E+00	2.8E-01	1.5E+02	2.8E-01	3.1E-04	1.6E-01	6.9E-02
U-236	2.3E+07	3.1E+01	2.3E+01	2.2E+02	2.0E+00	3.1E+01	3.8E+01	3.2E+00	1.8E+03	3.2E+00	3.6E-03	1.8E+00	7.8E-01
U-238	4.5E+09	2.0E+02	1.5E+02	1.5E+03	1.4E+01	2.1E+02	2.5E+02	7.8E+04	1.2E+04	2.1E+01	2.4E-02	1.2E+01	5.2E+00
Zr-93	1.5E+06	1.0E+01	1.3E+00	2.7E+01	1.1E-01	3.5E+00	4.2E+00	2.2E+00	4.4E+02	2.2E+00	7.3E-01		3.8E-01
Zr-95	1.8E-01								1.5E+09				
<b>Totals as listed</b>		<b>1.9E+09</b>	<b>1.4E+09</b>	<b>1.3E+10</b>	<b>7.4E+07</b>	<b>2.3E+11</b>	<b>2.8E+11</b>	<b>3.0E+10</b>	<b>6.6E+10</b>	<b>3.0E+10</b>	<b>6.1E+11</b>	<b>2.2E+08</b>	<b>3.0E+09</b>
<b>Totals with other short lived</b>		<b>2.1E+09</b>	<b>1.5E+09</b>	<b>1.3E+10</b>	<b>7.6E+07</b>	<b>2.3E+11</b>	<b>2.8E+11</b>	<b>3.0E+10</b>	<b>6.9E+10</b>	<b>3.0E+10</b>	<b>6.3E+11</b>	<b>2.2E+08</b>	<b>3.0E+09</b>

**Note:** Data in black based on direct measurement. Data in blue and red based on scaling factors and used fuel ratios respectively. Nuclides are listed if their half lives are greater than 1 yr.and/or there is significant inventory as-received. The total activity including all other short-lived nuclides is also shown. Sr-90 and Cs-137 have secular equilibrium daughters of potential significance due to contribution to total activity and/or gamma activity. Listed activity is that of parent plus daughter.

\* Feeder pipe activities are at feeder removal date. Other short lived are predominantly Fe-59, Ru-103, and Sb-124.

Report

OPG Proprietary		
Document Number:	00216-REP-03902-00003	Usage Classification: <b>INFORMATION</b>
Sheet Number:	N/A	Revision Number: R003
		Page: <b>55 of 136</b>

Title:

**REFERENCE LOW- AND INTERMEDIATE-LEVEL WASTE INVENTORY FOR THE DEEP GEOLOGIC REPOSITORY**

**Table B.2: Summary of Specific Activities of Operation Intermediate-Level Waste (As-Received)**

Nuclide	Half Life (yrs)	Estimated Specific Activity of Net Waste Volume (Bq/m <sup>3</sup> )						
		Moderator IX Resin*	PHT IX Resin*	Misc. IX Resin*	CANDECON Resin	IX Columns <sup>~</sup>	Irradiated Core Comp.	Filters and Filter Elements <sup>^</sup>
Ag-108m	1.3E+02		5.6E+05	1.4E+05	1.2E+04	5.6E+05		1.6E+03
Am-241	4.3E+02		1.0E+05	2.8E+07	6.8E+07	1.0E+05		2.9E+07
Am-242m	1.5E+02							
Am-243	7.4E+03		1.2E+03	3.4E+04	5.2E+04	1.2E+03		4.2E+04
C-14	5.7E+03	2.7E+12	8.8E+10	1.5E+10	1.0E+08	8.8E+10	7.9E+10	7.7E+09
Ce-141	8.9E-02	1.2E+09	3.3E+08	2.2E+10	5.1E+09	3.3E+08		
Ce-144	7.8E-01	5.3E+08	5.4E+09	6.3E+06	1.5E+10	5.4E+09		8.8E+07
Cl-36	3.0E+05	3.4E+05	3.0E+03	2.7E+04	6.8E+03	3.0E+03		4.5E+03
Cm-244	1.8E+01		4.5E+06	4.8E+06	2.9E+07	4.5E+06		2.2E+08
Co-60	5.3E+00	5.1E+10	3.0E+09	2.7E+10	4.9E+10	3.0E+09	2.7E+12	4.5E+09
Cs-134	2.1E+00	4.1E+08	2.7E+10	4.0E+09	3.9E+08	2.7E+10		0.0E+00
Cs-135	2.3E+06		5.5E+04	1.4E+04	1.2E+03	5.5E+04		1.6E+02
Cs-137+ Ba-137m	3.0E+01	3.6E+08	1.1E+11	2.6E+10	2.4E+09	1.1E+11		3.0E+08
Eu-152	1.3E+01	1.2E+09	4.9E+09	1.0E+06	1.3E+07	4.9E+09		
Eu-154	8.8E+00	6.4E+08		1.0E+06	7.3E+08			
Eu-155	5.0E+00	4.8E+07		1.1E+07	2.4E+07			
Fe-55	2.7E+00	1.4E+10	3.5E+08	3.4E+10	2.0E+11	3.5E+08	1.4E+13	1.5E+10
Gd-153	6.6E-01	5.8E+11						
H-3	1.2E+01	1.4E+11	1.1E+11	4.0E+11	7.5E+10	1.1E+11	4.7E+08	
I-129	1.6E+07	2.2E+02	6.5E+04	4.7E+03	4.5E+01	6.5E+04		5.4E+01
Ir-192m	2.4E+02						2.2E+06	
Mo-93	3.5E+03						1.7E+07	
Mn-54	8.6E-01		1.1E+10			1.1E+10		
Nb-93m	1.4E+01						1.7E+10	
Nb-94	2.0E+04		1.1E+07	1.5E+05	1.7E+06	1.1E+07	2.1E+05	6.7E+07
Nb-95	9.5E-02	8.5E+08	6.8E+09	2.7E+10	7.7E+09	6.8E+09		1.3E+10
Ni-59	7.5E+04	1.4E+07	5.9E+04	1.6E+07	1.5E+07	5.9E+04	1.0E+10	1.8E+06
Ni-63	9.6E+01	2.0E+09	8.2E+06	2.5E+09	2.2E+09	8.2E+06	1.7E+12	2.6E+08
Np-237	2.1E+06		5.9E+01	1.6E+03	2.9E+03	5.9E+01		2.0E+03
Pt-193	5.0E+01						2.7E+08	
Pu-238	8.8E+01	9.5E+02	2.8E+05	6.9E+06	7.0E+06	2.8E+05		9.7E+06
Pu-239	2.4E+04	1.3E+03	3.8E+05	1.5E+07	1.6E+07	3.8E+05		1.3E+07
Pu-240	6.5E+03	1.9E+03	5.5E+05	2.2E+07	2.3E+07	5.5E+05		1.9E+07
Pu-241	1.4E+01	3.7E+03	1.1E+06	3.8E+09	2.1E+09	1.1E+06		2.5E+07
Pu-242	3.8E+05	1.9E+00	5.6E+02	1.6E+04	2.4E+04	5.6E+02		1.9E+04
Ru-106	1.0E+00	1.4E+09	1.3E+10	2.9E+06	8.1E+09	1.3E+10		
Sb-124	1.7E-01	3.1E+08	1.0E+09	5.8E+09	3.3E+09	1.0E+09		7.8E+09
Sb-125	2.8E+00	9.9E+08	9.2E+08	1.9E+09	2.2E+09	9.2E+08	1.3E+13	2.2E+09
Se-79	3.8E+05	1.1E+01	1.9E+03	4.9E+02	4.6E+00	1.9E+03		5.6E+00

Report

OPG Proprietary		
Document Number:	00216-REP-03902-00003	Usage Classification: <b>INFORMATION</b>
Sheet Number:	Revision Number: R003	Page: 56 of 136

Title:

**REFERENCE LOW- AND INTERMEDIATE-LEVEL WASTE INVENTORY FOR THE DEEP GEOLOGIC REPOSITORY**

Nuclide	Half Life (yrs)	Estimated Specific Activity of Net Waste Volume (Bq/m <sup>3</sup> )						
		Moderator IX Resin*	PHT IX Resin*	Misc. IX Resin*	CANDECON Resin	IX Columns <sup>~</sup>	Irradiated Core Comp.	Filters and Filter Elements <sup>^</sup>
Sm-151	9.0E+01		1.9E+05	4.7E+04	4.0E+03	1.9E+05		5.4E+02
Sn-121m	5.5E+01						4.7E+10	
Sn-126	2.1E+05		2.9E+05	7.3E+04	6.2E+03	2.9E+05		8.3E+02
Sr-90+Y-90	2.9E+01	2.8E+07	5.8E+08	2.2E+09	5.0E+10	5.8E+08	4.0E+08	2.0E+08
Tc-99	2.1E+05		2.1E+05	5.4E+03	1.4E+03	2.1E+05	1.6E+07	9.0E+02
U-233	1.6E+05							
U-234	2.5E+05		6.3E+02	1.7E+04	2.7E+04	6.3E+02		2.1E+04
U-235	7.0E+08		1.0E+01	2.9E+02	4.3E+02	1.0E+01		3.5E+02
U-236	2.3E+07		1.2E+02	3.2E+03	4.9E+03	1.2E+02		4.0E+03
U-238	4.5E+09	2.7E+00	7.8E+02	2.2E+04	3.3E+04	7.8E+02		2.6E+04
Zr-93	1.5E+06	4.5E+02	1.9E+03	6.7E+01	4.5E+03	1.9E+03	2.5E+10	1.4E+03
Zr-95	1.8E-01				1.6E+10			4.7E+09
<b>Totals as listed</b>		<b>3.5E+12</b>	<b>3.8E+11</b>	<b>5.7E+11</b>	<b>4.4E+11</b>	<b>3.8E+11</b>	<b>3.2E+13</b>	<b>5.6E+10</b>
<b>Totals with other short lived</b>		<b>3.6E+12</b>	<b>4.0E+11</b>	<b>5.7E+11</b>	<b>4.7E+11</b>	<b>4.0E+11</b>	<b>3.2E+13</b>	<b>6.0E+10</b>

**Note:** Data in black based on direct measurement. Data in blue, red, and purple based on scaling factors, used fuel ratios, and neutron activation calculations respectively.

Nuclides are listed if their half lives are greater than 1 yr. and/or there is significant inventory as-received. The total activity including all other short-lived nuclides is also shown.

Sr-90 and Cs-137 have secular equilibrium daughters of potential significance. Listed activity is that of parent plus daughter.

\* Resin activities decay corrected back to the time resin was assumed to have been emptied into the station resin storage tanks.

~ IX Columns are Pickering PHT IX resin waste form.

+ Based on 6 flux detectors per core component liner.

^ Other short lived is mostly Cr-51.

Report

OPG Proprietary		
Document Number:	00216-REP-03902-00003	Usage Classification: <b>INFORMATION</b>
Sheet Number:	Revision Number: R003	Page: 57 of 136

Title:

**REFERENCE LOW- AND INTERMEDIATE-LEVEL WASTE INVENTORY FOR THE DEEP GEOLOGIC REPOSITORY**

Table B.3: Summary of Specific Activities of Reactor Refurbishment Wastes

Nuclide	Half Life (yrs)	Estimated Specific Activity of Net Waste Volume (Bq/m <sup>3</sup> )				
		Re-tube Waste Pressure Tubes*	Re-tube Waste End Fittings*	Re-tube Waste Calandria Tubes*	Re-tube Waste Calandria Tube Inserts*	Steam Generators <sup>®</sup>
Ag-108m	1.3E+02	7.8E+10	4.5E+08	6.5E+10	1.1E+09	2.2E+02
Ag-110m	6.8E-01	7.7E+07	2.2E+07	6.3E+07	3.6E+07	1.1E+07
Am-241	4.3E+02	7.1E+07				2.7E+08
Am-242m	1.5E+02	1.2E+05				2.7E+05
Am-243	7.4E+03					3.1E+05
C-14	5.7E+03	2.6E+12		2.4E+11	9.5E+10	1.2E+08
Ce-144	7.8E-01	2.1E+02		8.6E+01	4.9E+00	5.3E+08
Cl-36	3.0E+05	7.3E+09		8.6E+08	8.4E+06	6.8E+03
Cm-244	1.8E+01					1.4E+08
Co-60	5.3E+00	7.7E+12	4.7E+13	6.3E+12	1.2E+14	6.8E+09
Cr-51	7.6E-02	3.6E-07	1.2E-05	1.5E-06	3.1E-05	1.2E+08
Cs-134	2.1E+00	5.5E+09	2.3E+08	9.6E+07	5.7E+08	1.7E+06
Cs-135	2.3E+06	1.4E+06	7.9E+02	2.5E+04	2.2E+03	2.0E+01
Cs-137+Ba-137m	3.0E+01	7.6E+07	4.3E+02	1.5E+06	1.2E+03	4.0E+07
Eu-152	1.3E+01	4.0E-01	1.1E-04	1.6E-01	3.2E-04	1.7E+06
Eu-154	8.8E+00	6.2E+03	2.6E-02	2.6E+03	7.3E-02	1.5E+07
Eu-155	5.0E+00	3.0E+03	8.3E-03	1.3E+03	2.4E-02	2.7E+07
Fe-55	2.7E+00	3.7E+13	6.0E+14	2.5E+13	1.5E+15	1.8E+10
Fe-59	1.2E-01	1.3E+01	3.0E+01	9.6E+00	7.9E+01	1.6E+08
H-3	1.2E+01	1.1E+10	1.1E+10	3.3E+09	2.4E+10	8.0E+08
I-129	1.6E+07	1.8E+03	2.6E+01	3.7E+02	6.8E+01	7.1E+00
Ir-192m	2.4E+02	5.5E+07	2.1E+04	2.5E+06	6.0E+04	
Mn-54	8.6E-01	1.5E+10	5.0E+11	7.6E+09	1.3E+12	2.0E+08
Mo-93	3.5E+03	1.5E+08	4.7E+08	1.3E+08	1.2E+09	
Nb-93m	1.4E+01	3.6E+11	2.0E+08	2.1E+11	5.1E+08	
Nb-94	2.0E+04	2.3E+13	3.6E+08	2.0E+09	9.1E+08	2.7E+05
Nb-95	9.5E-02	1.0E+08	1.6E+01	5.8E+07	4.3E+01	2.4E+09
Ni-59	7.5E+04	1.4E+09	1.5E+10	2.0E+10	3.8E+10	5.8E+06
Ni-63	9.6E+01	5.3E+11	2.1E+12	7.2E+12	5.3E+12	8.1E+08
Np-237	2.1E+06					1.5E+04
Pt-193	5.0E+01	8.1E+10	6.8E+07	4.0E+09	1.8E+08	
Pu-238	8.8E+01	2.4E+07				7.9E+07
Pu-239	2.4E+04	4.3E+07				9.7E+07
Pu-240	6.5E+03	5.9E+07				1.4E+08
Pu-241	1.4E+01	9.6E+08				3.5E+09
Pu-242	3.8E+05	6.5E+04				1.4E+05
Ru-106	1.0E+00	8.5E-06	2.9E-09	7.6E-06	8.2E-09	7.7E+08
Sb-124	1.7E-01	1.7E+03	6.7E+02	2.9E+04	1.7E+03	6.8E+08
Sb-125	2.8E+00	1.1E+11	6.0E+10	5.0E+13	1.6E+11	1.8E+07
Se-79	3.8E+05	1.6E+07	5.3E+05	5.4E+07	1.5E+06	7.3E-01

Report

OPG Proprietary		
Document Number:	00216-REP-03902-00003	Usage Classification: <b>INFORMATION</b>
Sheet Number:	Revision Number: R003	Page: 58 of 136

Title:

**REFERENCE LOW- AND INTERMEDIATE-LEVEL WASTE INVENTORY FOR THE DEEP GEOLOGIC REPOSITORY**

Nuclide	Half Life (yrs)	Estimated Specific Activity of Net Waste Volume (Bq/m <sup>3</sup> )				
		Re-tube Waste Pressure Tubes*	Re-tube Waste End Fittings*	Re-tube Waste Calandria Tubes*	Re-tube Waste Calandria Tube Inserts*	Steam Generators <sup>®</sup>
Sm-151	9.0E+01	1.1E+02	3.6E-03	4.4E+01	1.0E-02	7.1E+01
2Sn-113+In113m	3.2E-01	9.0E+06	5.2E+06	4.6E+09	1.3E+07	7.0E+07
Sn-119m	8.0E-01	2.9E+10	1.2E+10	9.0E+12	3.1E+10	
Sn-121m	5.5E+01	1.7E+09	6.3E+08	8.5E+11	1.6E+09	
Sn-126	2.1E+05					1.1E+02
Sr-90+Y-90	2.9E+01	2.6E+10	6.2E+02	1.2E+10	1.7E+03	2.2E+09
Tc-99	2.1E+05	9.6E+07	1.2E+07	5.2E+07	2.9E+07	1.4E+03
Te-123m	3.3E-01	2.7E+07	1.9E+06	1.0E+09	5.3E+06	
Te-125m	1.6E-01	2.6E+10	1.5E+10	1.2E+13	3.8E+10	
U-232	7.2E+01	1.1E+04				2.6E+04
U-233	1.6E+05	1.5E+04				3.5E+04
U-234	2.5E+05	7.1E+04				1.6E+05
U-235	7.0E+08	1.1E+03				2.6E+03
U-236	2.3E+07	1.3E+04				2.9E+04
U-238	4.5E+09	8.9E+04				2.0E+05
Zr-93	1.5E+06	6.9E+11	9.7E+04	4.0E+11	2.5E+05	3.5E+02
Zr-95	1.8E-01	4.6E+07	7.5E+00	2.7E+07	1.9E+01	1.2E+09
<b>Totals as listed</b>		<b>7.2E+13</b>	<b>6.4E+14</b>	<b>1.1E+14</b>	<b>1.6E+15</b>	<b>3.9E+10</b>
<b>Totals with other short lived</b>		<b>7.3E+13</b>	<b>6.4E+14</b>	<b>1.1E+14</b>	<b>1.7E+15</b>	<b>4.0E+10</b>

**Note:** Data in black based on direct measurement. Data in blue, red, and purple based on scaling factors, used fuel ratios, and neutron activation calculations respectively.  
 Sr-90, Sn-113, and Cs-137 have secular eq'm daughters of potential significance due to contribution to total activity and/or gamma activity. Listed activity is that of parent plus daughter.

\* Activated metal based on PB retube components, decayed 5 years to account for cooling period before transfer to DGR.

<sup>®</sup> Activities based on Bruce A tube sections decay corrected back to reactor shutdown.

Report

OPG Proprietary		
Document Number:	00216-REP-03902-00003	Usage Classification: <b>INFORMATION</b>
Sheet Number:	N/A	Revision Number: R003
		Page: 59 of 136

Title:  
**REFERENCE LOW- AND INTERMEDIATE-LEVEL WASTE INVENTORY FOR THE DEEP GEOLOGIC REPOSITORY**

**Appendix C: Chemical and Physical Characteristics of Operational and Refurbishment Low- and Intermediate-Level Waste**

**Table C.1: Chemical Composition of Low- and Intermediate-Level Waste**

Contaminant	Bottom Ash Old (µg/g)	Baghouse Ash Old (µg/g)	Bottom Ash New (µg/g)	Baghouse Ash New (µg/g)	Bales/Box Compacted (µg/g)	Non-pro^ (µg/g)	Heat Exchangers (kg/HX)	CANDECON Resin (µg/g)	Misc. IX Resin (µg/g)	LL/ALW Resin (µg/g)	ALW Sludge (µg/g)	PHT IX Resin/IX Columns (µg/g)	Moderat or IX Resin (µg/g)	Filters and Filter Elements (µg/g)	Core Components# (µg/g)
Aluminum	3.3E+04		4.2E+04	1.4E+03	2.50E+03	1.1E+04		1.2E+01	1.3E+02	1.2E+01	2.4E+01	7.3E+01	5.9E+00	2.9E+03	
Antimony	1.0E+03		1.3E+03	9.9E+02	7.4E+01	2.7E+01		5.9E-02	2.7E-01	3.4E-02	7.9E-02	4.9E-01	4.3E-01		
Arsenic	1.2E+02		8.6E+00	4.4E+00	9.0E+00	3.4E+00		6.5E-01	1.7E+00	1.4E-01	2.0E-02	5.2E+00	2.8E-01		
Barium	3.0E+03		3.6E+03	5.0E+01	2.3E+02	8.4E+01		2.7E-01	1.4E+01	2.6E+01	1.3E+01	7.9E+01	5.9E+00		
Beryllium			1.3E+00	8.6E-01		6.5E+00		3.6E-01	3.8E-01	1.2E-01	2.0E-02	1.2E+01	5.0E-01		
Bismuth			6.8E+00	5.9E+00				1.7E+00	2.1E-01	1.9E-02	2.0E-02	5.1E-01	5.0E-01		
Boron	5.5E+02		3.5E+02	3.5E+01	4.1E+01	1.5E+01	8.3E-02	4.1E+01	1.8E+02	5.0E-01	8.9E+00	2.5E+01	4.2E+02	3.5E+03	
Bromine								1.0E-01	1.6E-01	5.0E+01					
Cadmium	6.2E+00		1.3E+01	2.0E+01	4.9E+02	1.8E+02		2.1E+00	2.0E+00	2.3E-01	3.8E-02	7.1E-02	7.1E+00		
Calcium	5.5E+04	4.0E+03	1.5E+05	3.1E+05	4.1E+03	3.3E+03	8.3E-02	1.1E+01	2.8E+03	2.1E+04	2.9E+02	9.1E+01	6.8E+01		
Cerium										5.0E-02			5.0E-02		
Carbon	1.1E+05	4.8E+05	1.9E+04	2.4E+05	3.0E+05	1.3E+04	2.0E+01	3.0E+05	3.6E+05	3.6E+05		3.6E+05	3.6E+05	9.4E+04	
Cesium			5.7E-01	4.7E-01				1.0E-02	7.7E-02	1.1E-02	2.0E-02	5.6E-02			
Chlorine	4.0E+03	1.1E+05	7.1E+03	3.9E+04	5.3E+02	3.1E+03		6.7E-01	6.6E+01	1.7E+03		2.3E+02	6.2E+02	2.9E+03	
Chromium	7.0E+03		3.7E+03	1.0E+02	5.2E+02	2.2E+04	2.9E+00	8.8E+00	7.9E+00	1.1E+00	2.8E-01	1.6E+01	1.3E+01	2.6E+04	2.00E+05
Cobalt	1.2E+02		9.8E+01	4.4E+00	9.0E+00	3.3E+00		9.1E+00	2.3E+00	7.1E-01	3.2E-02	1.5E-01	6.1E-01		
Copper	2.3E+04		7.7E+03	2.0E+02	1.7E+03	1.1E+05	1.4E+04	6.9E+01	2.3E+03	6.4E+01	1.2E+00	1.4E+01	4.5E+02		
Fluorine													8.2E+01		
Gadolinium								6.7E-02	6.1E+00			6.2E+02	2.7E+03		
Hydrogen								7.9E+04	8.7E+04	8.7E+04		8.7E+04	8.7E+04	1.7E+04	
Iodine								2.5E-02	4.6E-02	2.6E+01					
Iron	4.5E+04	4.0E+03	7.4E+04	2.6E+03	2.6E+05	1.8E+05	3.1E+03	1.8E+04	1.4E+03	8.9E+01	2.7E+01	3.5E+02	4.8E+02	7.3E+05	1.00E+05
Lead	1.3E+04		8.9E+02	5.0E+02	9.6E+02	8.6E+04	4.1E+00	4.3E+01	7.1E+01	3.1E+00	7.5E-01	6.8E+00	5.6E+01		
Lithium			6.0E+01	7.8E+00				6.6E+00	1.4E+02	8.0E-01	1.9E-01	3.3E+03	2.4E+02		
Magnesium	8.0E+03		3.0E+04	3.8E+03	5.9E+02	5.3E+02	2.3E+02	5.3E+00	6.3E+02	2.2E+03	7.3E+01	2.1E+01	8.3E+00		
Manganese	4.0E+03		1.4E+03	9.1E+01	2.7E+03	1.4E+03	6.2E+03	2.7E+02	5.6E+01	1.6E+01	2.6E+00	5.6E+01	1.5E+01	4.7E+03	
Mercury	2.0E+01		1.3E+00	4.3E-01	2.1E+00	1.3E+00		4.2E-02	2.4E-02	1.2E-01	2.0E-02	6.8E-02	3.8E-02		
Molybdenum			3.1E+02	2.5E+01				1.5E+00	2.8E+00	8.7E-01	2.7E-02	2.4E+01	1.6E+00		
Nickel	2.0E+03		1.4E+03	8.4E+01	1.5E+02	1.4E+03	8.0E+00	2.2E+03	2.4E+02	1.5E+01	2.4E+00	6.6E+00	2.8E+03	1.6E+04	7.00E+05
Niobium	4.0E+01				3.5E+00	1.3E+00									

Report

<b>OPG Proprietary</b>		
Document Number: <b>00216-REP-03902-00003</b>	Usage Classification: <b>INFORMATION</b>	
Sheet Number: <b>N/A</b>	Revision Number: <b>R003</b>	Page: <b>60 of 136</b>

Title:  
**REFERENCE LOW- AND INTERMEDIATE-LEVEL WASTE INVENTORY FOR THE DEEP GEOLOGIC REPOSITORY**

Contaminant	Bottom Ash Old (µg/g)	Baghouse Ash Old (µg/g)	Bottom Ash New (µg/g)	Baghouse Ash New (µg/g)	Bales/Box Compacted (µg/g)	Non-pro^ (µg/g)	Heat Exchangers (kg/HX)	CANDECON Resin (µg/g)	Misc. IX Resin (µg/g)	LL/ALW Resin (µg/g)	ALW Sludge (µg/g)	PHT IX Resin/IX Columns (µg/g)	Moderat or IX Resin (µg/g)	Filters and Filter Elements (µg/g)	Core Components# (µg/g)
Nitrate ion	5.3E+04				3.9E+03	1.4E+03		5.2E-01	2.4E+01				3.8E+02		
Nitrogen								6.1E+03	2.0E+04	2.2E+04		2.0E+04	2.0E+04	2.0E+02	
Oxygen								5.2E+05	4.8E+05	4.8E+05		4.8E+05	4.8E+05	1.2E+04	
Phosphorus	3.0E+03	4.6E+04	1.6E+04	1.9E+03	1.3E+03	4.3E+03		7.8E+01	2.1E+02	3.3E+01	6.1E+00	1.0E+02	1.6E+02	2.0E+03	
Potassium	3.0E+03		5.0E+03	1.4E+03	2.2E+02	9.5E+01		1.3E+02	8.0E+02	8.2E+01	6.5E+01	1.0E+02	2.2E+01		
Rubidium										9.6E-02					
Scandium	4.0E+01		1.3E+00										3.4E-02		
Selenium					3.5E+00	1.3E+00		3.4E-01	1.9E+00	3.1E-01	1.4E-01	5.0E-01	5.0E-01		
Silicon	3.6E+04	9.0E+03	8.3E+04	8.4E+03	2.6E+04	1.5E+05	4.0E+00	1.7E+01	7.9E+01	2.5E+01	6.3E+01	1.1E+02	1.5E+01	8.0E+04	
Silver			5.6E+00	2.4E+00				5.8E-02	1.6E-01	3.7E-01	2.5E-02	1.1E-01	2.8E-01		
Sodium	6.0E+03	4.8E+04	1.2E+04	1.0E+04	5.5E+02	9.1E+03		8.9E+01	2.0E+03	5.3E+02	6.1E+03	2.0E+02	8.2E+01	7.1E+03	
Strontium	1.0E+03		4.4E+02	1.5E+02	7.4E+01	3.4E+01		8.7E-02	2.3E+01	2.2E+02	3.2E+00	1.0E+00	3.3E-01		
Sulphur	2.0E+03	7.6E+04	1.0E+04	1.3E+04	3.5E+02	2.2E+03	1.5E+01	8.0E+04	3.1E+04	5.4E+04		3.3E+04	3.1E+04	2.0E+03	
Tellurium	9.0E+01				6.9E+00	2.5E+00									
Thallium			1.5E-01	1.9E-01				4.7E-02	2.2E-02	1.5E-02	2.0E-02	5.0E-02	5.0E-02		
Thorium			8.0E+00	3.1E-01				7.7E-01	7.3E-02	1.5E-02	1.7E-02	5.0E-02	5.0E-02		
Tin			1.9E+02	5.1E+01				3.9E+00	1.0E+00	2.4E-01	6.6E-02	3.3E+00	1.0E+00		
Titanium	1.6E+04		6.8E+04	3.8E+02	1.2E+03	4.0E+03	1.7E+00	1.1E+00	2.2E+01	4.3E-02	5.1E-01	4.3E-01	1.1E-01		
Tungsten								7.4E-02	1.3E+00	4.3E-01	2.0E-02	5.0E+00	9.7E-02		
Uranium			4.6E+00	1.9E+00		1.9E+01		1.1E+01	1.2E+00	1.1E-01	2.0E-02	1.1E+00	5.6E-02		
Vanadium			1.2E+02	6.9E+01				2.9E-02	1.4E+00	1.1E-01	2.0E-02	1.4E+00	5.0E-02		
Zinc	4.1E+04	5.1E+04	1.8E+04	3.4E+03	3.1E+03	2.5E+03	1.6E+02	3.5E+01	1.1E+03	5.0E+01	3.0E+01	3.8E+01	2.5E+02		
Zirconium	2.8E+02		1.8E+02	7.1E+00	2.0E+01	7.7E+00		3.3E-02	5.5E-01	1.6E-01	9.5E-02	1.1E-01	1.4E-01		
Asbestos						1.8E+04									
EDTA								2.6E+04							
PAH	2.3E+00	1.0E-01	1.9E-01	1.7E+01											
Cl-Benzenes & Cl-Phenols	3.3E+00	2.6E+01	4.7E-01	1.3E+00											
Dioxins & Furans	7.6E-02	7.9E-02	4.6E-02	1.5E-01											
PCB	2.0E-01	1.0E-01	2.4E-02	2.7E-02											
Balance *	5.3E+05	1.7E+05	4.4E+05	3.6E+05	3.9E+05	3.7E+05	0.0E+00	0.0E+00	0.0E+00	0.0E+00	9.9E+05	0.0E+00	0.0E+00	0.0E+00	0.0E+00
<b>Total</b>	<b>1.0E+06</b>	<b>1.0E+06</b>	<b>1.0E+06</b>	<b>1.0E+06</b>	<b>1.0E+06</b>	<b>1.0E+06</b>	<b>2.4E+04</b>	<b>1.0E+06</b>	<b>1.0E+06</b>	<b>1.0E+06</b>	<b>1.0E+06</b>	<b>1.0E+06</b>	<b>1.0E+06</b>	<b>1.0E+06</b>	<b>1.0E+06</b>

\* C, H, O, N not necessarily tracked in mass balance measurements and generally accounts for most of the mass balance, except for ALW sludge where the clay component is significant.

^ Includes feeder pipes, ETHs, and drummed non-pro waste.

# Based on Pickering flux detectors.



Report

OPG Proprietary		
Document Number:	00216-REP-03902-00003	Usage Classification: <b>INFORMATION</b>
Sheet Number:	N/A	Revision Number: <b>R003</b>
		Page: <b>61 of 136</b>

Title:

**REFERENCE LOW- AND INTERMEDIATE-LEVEL WASTE INVENTORY FOR THE DEEP GEOLOGIC REPOSITORY**

Table C.2: Pressure Tube Elemental Composition

Element	PPM	wt%	Partial density (g/cm <sup>3</sup> )	Atomic Mass (mol)	Atomic Number	ORIGEN-S Input for 1Kg of material
Li	2.00E-03	2.00E-07	1.31E-08	6.94E+00	3	2.00E-06
Be	1.00E-03	1.00E-07	6.55E-09	9.01E+00	4	1.00E-06
B	7.00E-02	7.00E-06	4.58E-07	1.08E+01	5	7.00E-05
C	8.80E+01	8.80E-03	5.76E-04	1.20E+01	6	8.80E-02
N	5.40E+01	5.40E-03	3.54E-04	1.40E+01	7	5.40E-02
O	3.06E+03	3.06E-01	2.00E-02	1.60E+01	8	3.06E+00
F	1.70E-01	1.70E-05	1.11E-06	1.90E+01	9	1.70E-04
Na	4.50E-02	4.50E-06	2.95E-07	2.30E+01	11	4.50E-05
Mg	1.20E-01	1.20E-05	7.86E-07	2.43E+01	12	1.20E-04
Al	4.50E+01	4.50E-03	2.95E-04	2.70E+01	13	4.50E-02
Si	3.60E+01	3.60E-03	2.36E-04	2.81E+01	14	3.60E-02
P	9.00E+00	9.00E-04	5.89E-05	3.10E+01	15	9.00E-03
S	7.00E+00	7.00E-04	4.58E-05	3.21E+01	16	7.00E-03
Cl	6.00E+00	6.00E-04	3.93E-05	3.91E+01	17	6.00E-03
K	4.00E-02	4.00E-06	2.62E-07	3.91E+01	19	4.00E-05
Ca	3.00E-02	3.00E-06	1.96E-07	4.01E+01	20	3.00E-05
Sc	1.00E+00	1.00E-04	6.55E-06	4.50E+01	21	1.00E-03
Ti	9.00E+00	9.00E-04	5.89E-05	4.79E+01	22	9.00E-03
V	5.00E-01	5.00E-05	3.27E-06	5.09E+01	23	5.00E-04
Cr	4.70E+01	4.70E-03	3.08E-04	5.20E+01	24	4.70E-02
Mn	3.00E+00	3.00E-04	1.96E-05	5.49E+01	25	3.00E-03
Fe	4.94E+02	4.94E-02	3.23E-03	5.58E+01	26	4.94E-01
Co	3.00E-01	3.00E-05	1.96E-06	5.89E+01	27	3.00E-04
Ni	1.00E+01	1.00E-03	6.55E-05	5.87E+01	28	1.00E-02
Cu	7.00E+00	7.00E-04	4.58E-05	6.35E+01	29	7.00E-03
Zn	7.00E-02	7.00E-06	4.58E-07	6.54E+01	30	7.00E-05
Ga	1.00E-01	1.00E-05	6.55E-07	6.97E+01	31	1.00E-04
Ge	1.00E-02	1.00E-06	6.55E-08	7.26E+01	32	1.00E-05
As	4.00E-02	4.00E-06	2.62E-07	7.49E+01	33	4.00E-05
Se	4.00E-02	4.00E-06	2.62E-07	7.90E+01	34	4.00E-05
Br	4.00E-02	4.00E-06	2.62E-07	7.99E+01	35	4.00E-05
Rb	2.00E-01	2.00E-05	1.31E-06	8.55E+01	37	2.00E-04
Sr	6.00E-02	6.00E-06	3.93E-07	8.76E+01	38	6.00E-05
Y	2.00E-01	2.00E-05	1.31E-06	8.89E+01	39	2.00E-04
Zr	9.71E+05	9.71E+01	6.36E+00	9.12E+01	40	9.71E+02
Nb	2.50E+04	2.50E+00	1.64E-01	9.29E+01	41	2.50E+01
Mo	2.00E+00	2.00E-04	1.31E-05	9.59E+01	42	2.00E-03
Ag	1.00E+00	1.00E-04	6.55E-06	1.08E+02	47	1.00E-03
Cd	1.00E+00	1.00E-04	6.55E-06	1.12E+02	48	1.00E-03
In	3.00E+02	3.00E-02	1.96E-03	1.15E+02	49	3.00E-01
Sn	1.10E+01	1.10E-03	7.20E-05	1.19E+02	50	1.10E-02
Sb	1.00E+00	1.00E-04	6.55E-06	1.22E+02	51	1.00E-03
Te	4.00E-02	4.00E-06	2.62E-07	1.28E+02	52	4.00E-05
I	3.00E-03	3.00E-07	1.96E-08	1.27E+02	53	3.00E-06
Cs	4.00E-02	4.00E-06	2.62E-07	1.33E+02	55	4.00E-05
Ba	3.00E-03	3.00E-07	1.96E-08	1.37E+02	56	3.00E-06
La	2.00E-03	2.00E-07	1.31E-08	1.39E+02	57	2.00E-06
Ce	2.00E-03	2.00E-07	1.31E-08	1.40E+02	58	2.00E-06
Hf	3.80E+01	3.80E-03	2.49E-04	1.78E+02	72	3.80E-02
Ta	3.50E+01	3.50E-03	2.29E-04	1.81E+02	73	3.50E-02
W	7.00E+00	7.00E-04	4.58E-05	1.84E+02	74	7.00E-03
Pt	4.00E-02	4.00E-06	2.62E-07	1.95E+02	78	4.00E-05
Au	7.00E-03	7.00E-07	4.58E-08	1.97E+02	79	7.00E-06
Hg	3.00E-02	3.00E-06	1.96E-07	2.01E+02	80	3.00E-05
Tl	7.00E-03	7.00E-07	4.58E-08	2.04E+02	81	7.00E-06
Pb	2.00E+00	2.00E-04	1.31E-05	2.07E+02	82	2.00E-03
Bi	1.00E-02	1.00E-06	6.55E-08	2.09E+02	83	1.00E-05
Th	1.90E-01	1.90E-05	1.24E-06	2.32E+02	90	1.90E-04
U	3.00E-01	3.00E-05	1.96E-06	2.38E+02	92	3.00E-04
Sum	1.00E+06	1.00E+02	6.55E+00	-	-	1.00E+03

Report

OPG Proprietary		
Document Number:	00216-REP-03902-00003	Usage Classification: <b>INFORMATION</b>
Sheet Number:	N/A	Revision Number: <b>R003</b>
		Page: <b>62 of 136</b>

Title:

**REFERENCE LOW- AND INTERMEDIATE-LEVEL WASTE INVENTORY FOR THE DEEP GEOLOGIC REPOSITORY**

**Table C.3: Calandria Tube Elemental Composition**

Element	PPM	wt%	Partial density (g/cm <sup>3</sup> )	Atomic Mass (mol)	Atomic Number	ORIGEN-S Input for 1Kg of material
Li	1.13E-03	1.13E-07	7.40E-09	6.94E+00	3	1.13E-06
Be	6.67E-04	6.67E-08	4.37E-09	9.01E+00	4	6.67E-07
B	4.00E-02	4.00E-06	2.62E-07	1.08E+01	5	4.00E-05
C	5.78E+01	5.78E-03	3.78E-04	1.20E+01	6	5.78E-02
N	8.50E+00	8.50E-04	5.57E-05	1.40E+01	7	8.50E-03
O	1.00E+03	1.00E-01	6.55E-03	1.60E+01	8	1.00E+00
F	7.83E-02	7.83E-06	5.13E-07	1.90E+01	9	7.83E-05
Na	2.00E-02	2.00E-06	1.31E-07	2.30E+01	11	2.00E-05
Mg	5.50E-02	5.50E-06	3.60E-07	2.43E+01	12	5.50E-05
Al	4.08E+01	4.08E-03	2.67E-04	2.70E+01	13	4.08E-02
Si	1.80E+01	1.80E-03	1.18E-04	2.81E+01	14	1.80E-02
P	4.67E+00	4.67E-04	3.06E-05	3.10E+01	15	4.67E-03
S	1.72E+00	1.72E-04	1.13E-05	3.21E+01	16	1.72E-03
Cl	1.32E+00	1.32E-04	8.64E-06	3.91E+01	17	1.32E-03
K	2.67E-02	2.67E-06	1.75E-07	3.91E+01	19	2.67E-05
Ca	2.33E-02	2.33E-06	1.53E-07	4.01E+01	20	2.33E-05
Sc	4.33E-01	4.33E-05	2.83E-06	4.50E+01	21	4.33E-04
Ti	4.83E+00	4.83E-04	3.16E-05	4.79E+01	22	4.83E-03
V	4.00E-01	4.00E-05	2.62E-06	5.09E+01	23	4.00E-04
Cr	3.62E+02	3.62E-02	2.37E-03	5.20E+01	24	3.62E-01
Mn	1.37E+00	1.37E-04	8.97E-06	5.49E+01	25	1.37E-03
Fe	5.83E+02	5.83E-02	3.82E-03	5.58E+01	26	5.83E-01
Co	3.00E-01	3.00E-05	1.96E-06	5.89E+01	27	3.00E-04
Ni	2.50E+02	2.50E-02	1.64E-03	5.87E+01	28	2.50E-01
Cu	3.50E+00	3.50E-04	2.29E-05	6.35E+01	29	3.50E-03
Zn	2.03E-01	2.03E-05	1.33E-06	6.54E+01	30	2.03E-04
Ga	8.17E-01	8.17E-05	5.35E-06	6.97E+01	31	8.17E-04
Ge	2.00E-02	2.00E-06	1.31E-07	7.26E+01	32	2.00E-05
As	8.50E-01	8.50E-05	5.57E-06	7.49E+01	33	8.50E-04
Se	2.50E-02	2.50E-06	1.64E-07	7.90E+01	34	2.50E-05
Br	9.00E-03	9.00E-07	5.89E-08	7.99E+01	35	9.00E-06
Rb	2.00E-02	2.00E-06	1.31E-07	8.55E+01	37	2.00E-05
Sr	1.67E-02	1.67E-06	1.09E-07	8.76E+01	38	1.67E-05
Y	5.33E-02	5.33E-06	3.49E-07	8.89E+01	39	5.33E-05
Zr	9.88E+05	9.88E+01	6.47E+00	9.12E+01	40	9.88E+02
Nb	3.83E+00	3.83E-04	2.51E-05	9.29E+01	41	3.83E-03
Mo	2.98E+00	2.98E-04	1.95E-05	9.59E+01	42	2.98E-03
Ag	1.50E+00	1.50E-04	9.82E-06	1.08E+02	47	1.50E-03
Cd	6.67E-01	6.67E-05	4.37E-06	1.12E+02	48	6.67E-04
In	1.33E+00	1.33E-04	8.71E-06	1.15E+02	49	1.33E-03
Sn	1.00E+04	1.00E+00	6.55E-02	1.19E+02	50	1.00E+01
Sb	1.33E+00	1.33E-04	8.71E-06	1.22E+02	51	1.33E-03
Te	1.33E-02	1.33E-06	8.71E-08	1.28E+02	52	1.33E-05
I	3.00E-03	3.00E-07	1.96E-08	1.27E+02	53	3.00E-06
Cs	1.33E-03	1.33E-07	8.71E-09	1.33E+02	55	1.33E-06
Ba	4.50E-03	4.50E-07	2.95E-08	1.37E+02	56	4.50E-06
La	1.00E-03	1.00E-07	6.55E-09	1.39E+02	57	1.00E-06
Ce	1.33E-03	1.33E-07	8.71E-09	1.40E+02	58	1.33E-06
Hf	5.58E+01	5.58E-03	3.65E-04	1.78E+02	72	5.58E-02
Ta	0.00E+00	0.00E+00	0.00E+00	1.81E+02	73	0.00E+00
W	5.50E-01	5.50E-05	3.60E-06	1.84E+02	74	5.50E-04
Pt	4.50E-02	4.50E-06	2.95E-07	1.95E+02	78	4.50E-05
Au	4.83E-02	4.83E-06	3.16E-07	1.97E+02	79	4.83E-05
Hg	2.33E-02	2.33E-06	1.53E-07	2.01E+02	80	2.33E-05
Tl	7.17E-03	7.17E-07	4.69E-08	2.04E+02	81	7.17E-06
Pb	3.50E+00	3.50E-04	2.29E-05	2.07E+02	82	3.50E-03
Bi	2.50E-01	2.50E-05	1.64E-06	2.09E+02	83	2.50E-04
Th	1.03E-01	1.03E-05	6.74E-07	2.32E+02	90	1.03E-04
U	1.33E+00	1.33E-04	8.71E-06	2.38E+02	92	1.33E-03
Sum	1.00E+06	1.00E+02	6.55E+00	-	-	1.00E+03

Report

OPG Proprietary		
Document Number:	00216-REP-03902-00003	Usage Classification: <b>INFORMATION</b>
Sheet Number:	N/A	Revision Number: <b>R003</b>
		Page: <b>63 of 136</b>

Title:

**REFERENCE LOW- AND INTERMEDIATE-LEVEL WASTE INVENTORY FOR THE DEEP GEOLOGIC REPOSITORY**

Table C.4: Calandria Tube Inserts Elemental Composition

Element	PPM	wt%	Partial density (g/cm <sup>3</sup> )	Atomic Mass (mol)	Atomic Number	ORIGEN-S Input for 1kg of material
Li	5.00E-03	5.00E-07	3.90E-08	6.94E+00	3	5.00E-06
Be	2.00E-03	2.00E-07	1.56E-08	9.01E+00	4	2.00E-06
B	1.00E+00	1.00E-04	7.80E-06	1.08E+01	5	1.00E-03
C	1.10E+03	1.10E-01	8.58E-03	1.20E+01	6	1.10E+00
N	9.80E+01	9.80E-03	7.64E-04	1.40E+01	7	9.80E-02
O	9.10E+01	9.10E-03	7.10E-04	1.60E+01	8	9.10E-02
F	1.00E+00	1.00E-04	7.80E-06	1.90E+01	9	1.00E-03
Na	3.00E-02	3.00E-06	2.34E-07	2.30E+01	11	3.00E-05
Mg	2.00E+00	2.00E-04	1.56E-05	2.43E+01	12	2.00E-03
Al	1.70E+01	1.70E-03	1.33E-04	2.70E+01	13	1.70E-02
Si	3.30E+03	3.30E-01	2.57E-02	2.81E+01	14	3.30E+00
P	2.60E+02	2.60E-02	2.03E-03	3.10E+01	15	2.60E-01
S	8.90E+01	8.90E-03	6.94E-04	3.21E+01	16	8.90E-02
Cl	7.00E-02	7.00E-06	5.46E-07	3.91E+01	17	7.00E-05
K	3.00E-02	3.00E-06	2.34E-07	3.91E+01	19	3.00E-05
Ca	1.00E+01	1.00E-03	7.80E-05	4.01E+01	20	1.00E-02
Sc	2.00E-02	2.00E-06	1.56E-07	4.50E+01	21	2.00E-05
Ti	3.60E+01	3.60E-03	2.81E-04	4.79E+01	22	3.60E-02
V	4.10E+02	4.10E-02	3.20E-03	5.09E+01	23	4.10E-01
Cr	7.00E+04	7.00E+00	5.46E-01	5.20E+01	24	7.00E+01
Mn	4.70E+03	4.70E-01	3.67E-02	5.49E+01	25	4.70E+00
Fe	9.16E+05	9.16E+01	7.14E+00	5.58E+01	26	9.16E+02
Co	1.20E+02	1.20E-02	9.36E-04	5.89E+01	27	1.20E-01
Ni	1.70E+03	1.70E-01	1.33E-02	5.87E+01	28	1.70E+00
Cu	1.30E+03	1.30E-01	1.01E-02	6.35E+01	29	1.30E+00
Zn	7.00E+00	7.00E-04	5.46E-05	6.54E+01	30	7.00E-03
Ga	2.90E+01	2.90E-03	2.26E-04	6.97E+01	31	2.90E-02
Ge	1.30E+01	1.30E-03	1.01E-04	7.26E+01	32	1.30E-02
As	5.60E+01	5.60E-03	4.37E-04	7.49E+01	33	5.60E-02
Se	7.00E-02	7.00E-06	5.46E-07	7.90E+01	34	7.00E-05
Br	1.00E-02	1.00E-06	7.80E-08	7.99E+01	35	1.00E-05
Rb	2.00E-02	2.00E-06	1.56E-07	8.55E+01	37	2.00E-05
Sr	6.00E-02	6.00E-06	4.68E-07	8.76E+01	38	6.00E-05
Y	2.00E-02	2.00E-06	1.56E-07	8.89E+01	39	2.00E-05
Zr	1.30E+01	1.30E-03	1.01E-04	9.12E+01	40	1.30E-02
Nb	1.50E+01	1.50E-03	1.17E-04	9.29E+01	41	1.50E-02
Mo	4.00E+02	4.00E-02	3.12E-03	9.59E+01	42	4.00E-01
Ag	2.00E-01	2.00E-05	1.56E-06	1.08E+02	47	2.00E-04
Cd	1.00E-01	1.00E-05	7.80E-07	1.12E+02	48	1.00E-04
In	3.00E-01	3.00E-05	2.34E-06	1.15E+02	49	3.00E-04
Sn	2.80E+02	2.80E-02	2.18E-03	1.19E+02	50	2.80E-01
Sb	9.00E+00	9.00E-04	7.02E-05	1.22E+02	51	9.00E-03
Te	2.00E-02	2.00E-06	1.56E-07	1.28E+02	52	2.00E-05
I	3.00E-03	3.00E-07	2.34E-08	1.27E+02	53	3.00E-06
Cs	3.00E-03	3.00E-07	2.34E-08	1.33E+02	55	3.00E-06
Ba	4.00E-03	4.00E-07	3.12E-08	1.37E+02	56	4.00E-06
La	1.00E-02	1.00E-06	7.80E-08	1.39E+02	57	1.00E-05
Ce	3.00E-02	3.00E-06	2.34E-07	1.40E+02	58	3.00E-05
Hf	1.00E+02	1.00E-02	7.80E-04	1.78E+02	72	1.00E-01
Ta	0.00E+00	0.00E+00	0.00E+00	1.81E+02	73	0.00E+00
W	5.80E+01	5.80E-03	4.52E-04	1.84E+02	74	5.80E-02
Pt	2.00E-01	2.00E-05	1.56E-06	1.95E+02	78	2.00E-04
Au	4.00E-02	4.00E-06	3.12E-07	1.97E+02	79	4.00E-05
Hg	3.00E-02	3.00E-06	2.34E-07	2.01E+02	80	3.00E-05
Tl	8.00E-03	8.00E-07	6.24E-08	2.04E+02	81	8.00E-06
Pb	1.00E+00	1.00E-04	7.80E-06	2.07E+02	82	1.00E-03
Bi	4.00E-03	4.00E-07	3.12E-08	2.09E+02	83	4.00E-06
Th	5.00E-03	5.00E-07	3.90E-08	2.32E+02	90	5.00E-06
U	3.00E-03	3.00E-07	2.34E-08	2.38E+02	92	3.00E-06
Sum	1.00E+06	1.00E+02	7.80E+00	-	-	1.00E+03

Report

OPG Proprietary		
Document Number:	00216-REP-03902-00003	Usage Classification: <b>INFORMATION</b>
Sheet Number:	N/A	Revision Number: <b>R003</b>
		Page: <b>64 of 136</b>

Title:

**REFERENCE LOW- AND INTERMEDIATE-LEVEL WASTE INVENTORY FOR THE DEEP GEOLOGIC REPOSITORY**

Table C 5: End Fittings Elemental Composition

Element	PPM	wt%	Partial density (g/cm <sup>3</sup> )	Atomic Mass (mol)	Atomic Number	ORIGEN-S Input for 1kg of material
Li	5.00E-03	5.00E-07	3.90E-08	6.94E+00	3	5.00E-06
Be	2.00E-03	2.00E-07	1.56E-08	9.01E+00	4	2.00E-06
B	1.00E+00	1.00E-04	7.80E-06	1.08E+01	5	1.00E-03
C	1.10E+03	1.10E-01	8.58E-03	1.20E+01	6	1.10E+00
N	9.80E+01	9.80E-03	7.64E-04	1.40E+01	7	9.80E-02
O	9.10E+01	9.10E-03	7.10E-04	1.60E+01	8	9.10E-02
F	1.00E+00	1.00E-04	7.80E-06	1.90E+01	9	1.00E-03
Na	3.00E-02	3.00E-06	2.34E-07	2.30E+01	11	3.00E-05
Mg	2.00E+00	2.00E-04	1.56E-05	2.43E+01	12	2.00E-03
Al	1.70E+01	1.70E-03	1.33E-04	2.70E+01	13	1.70E-02
Si	3.30E+03	3.30E-01	2.57E-02	2.81E+01	14	3.30E+00
P	2.60E+02	2.60E-02	2.03E-03	3.10E+01	15	2.60E-01
S	8.90E+01	8.90E-03	6.94E-04	3.21E+01	16	8.90E-02
Cl	7.00E-02	7.00E-06	5.46E-07	3.91E+01	17	7.00E-05
K	3.00E-02	3.00E-06	2.34E-07	3.91E+01	19	3.00E-05
Ca	1.00E+01	1.00E-03	7.80E-05	4.01E+01	20	1.00E-02
Sc	2.00E-02	2.00E-06	1.56E-07	4.50E+01	21	2.00E-05
Ti	3.60E+01	3.60E-03	2.81E-04	4.79E+01	22	3.60E-02
V	4.10E+02	4.10E-02	3.20E-03	5.09E+01	23	4.10E-01
Cr	7.00E+04	7.00E+00	5.46E-01	5.20E+01	24	7.00E+01
Mn	4.70E+03	4.70E-01	3.67E-02	5.49E+01	25	4.70E+00
Fe	9.16E+05	9.16E+01	7.14E+00	5.58E+01	26	9.16E+02
Co	1.20E+02	1.20E-02	9.36E-04	5.89E+01	27	1.20E-01
Ni	1.70E+03	1.70E-01	1.33E-02	5.87E+01	28	1.70E+00
Cu	1.30E+03	1.30E-01	1.01E-02	6.35E+01	29	1.30E+00
Zn	7.00E+00	7.00E-04	5.46E-05	6.54E+01	30	7.00E-03
Ga	2.90E+01	2.90E-03	2.26E-04	6.97E+01	31	2.90E-02
Ge	1.30E+01	1.30E-03	1.01E-04	7.26E+01	32	1.30E-02
As	5.60E+01	5.60E-03	4.37E-04	7.49E+01	33	5.60E-02
Se	7.00E-02	7.00E-06	5.46E-07	7.90E+01	34	7.00E-05
Br	1.00E-02	1.00E-06	7.80E-08	7.99E+01	35	1.00E-05
Rb	2.00E-02	2.00E-06	1.56E-07	8.55E+01	37	2.00E-05
Sr	6.00E-02	6.00E-06	4.68E-07	8.76E+01	38	6.00E-05
Y	2.00E-02	2.00E-06	1.56E-07	8.89E+01	39	2.00E-05
Zr	1.30E+01	1.30E-03	1.01E-04	9.12E+01	40	1.30E-02
Nb	1.50E+01	1.50E-03	1.17E-04	9.29E+01	41	1.50E-02
Mo	4.00E+02	4.00E-02	3.12E-03	9.59E+01	42	4.00E-01
Ag	2.00E-01	2.00E-05	1.56E-06	1.08E+02	47	2.00E-04
Cd	1.00E-01	1.00E-05	7.80E-07	1.12E+02	48	1.00E-04
In	3.00E-01	3.00E-05	2.34E-06	1.15E+02	49	3.00E-04
Sn	2.80E+02	2.80E-02	2.18E-03	1.19E+02	50	2.80E-01
Sb	9.00E+00	9.00E-04	7.02E-05	1.22E+02	51	9.00E-03
Te	2.00E-02	2.00E-06	1.56E-07	1.28E+02	52	2.00E-05
I	3.00E-03	3.00E-07	2.34E-08	1.27E+02	53	3.00E-06
Cs	3.00E-03	3.00E-07	2.34E-08	1.33E+02	55	3.00E-06
Ba	4.00E-03	4.00E-07	3.12E-08	1.37E+02	56	4.00E-06
La	1.00E-02	1.00E-06	7.80E-08	1.39E+02	57	1.00E-05
Ce	3.00E-02	3.00E-06	2.34E-07	1.40E+02	58	3.00E-05
Hf	1.00E+02	1.00E-02	7.80E-04	1.78E+02	72	1.00E-01
Ta	0.00E+00	0.00E+00	0.00E+00	1.81E+02	73	0.00E+00
W	5.80E+01	5.80E-03	4.52E-04	1.84E+02	74	5.80E-02
Pt	2.00E-01	2.00E-05	1.56E-06	1.95E+02	78	2.00E-04
Au	4.00E-02	4.00E-06	3.12E-07	1.97E+02	79	4.00E-05
Hg	3.00E-02	3.00E-06	2.34E-07	2.01E+02	80	3.00E-05
Tl	8.00E-03	8.00E-07	6.24E-08	2.04E+02	81	8.00E-06
Pb	1.00E+00	1.00E-04	7.80E-06	2.07E+02	82	1.00E-03
Bi	4.00E-03	4.00E-07	3.12E-08	2.09E+02	83	4.00E-06
Th	5.00E-03	5.00E-07	3.90E-08	2.32E+02	90	5.00E-06
U	3.00E-03	3.00E-07	2.34E-08	2.38E+02	92	3.00E-06
Sum	1.00E+06	1.00E+02	7.80E+00	-	-	1.00E+03

Report

OPG Proprietary		
Document Number:	00216-REP-03902-00003	Usage Classification: <b>INFORMATION</b>
Sheet Number:	Revision Number: R003	Page: 65 of 136

Title:

**REFERENCE LOW- AND INTERMEDIATE-LEVEL WASTE INVENTORY FOR THE DEEP GEOLOGIC REPOSITORY**

**Table C.6: Low- and Intermediate-Level Waste for the Deep Geological Repository**

Waste Type	Material Characteristics
Old Bottom Ash	Coarse ash, heterogeneous (54 wt% > 9.5 mm).
Old Baghouse Ash	Fine ash, homogeneous (90 wt% < 0.8 mm).
New Bottom Ash	Light brown powder containing coarse materials. pH increasing < 9 in 1% ash in water to 11 in 29% ash in water.
New Baghouse Ash	Fine grey powder, with pH ranging from 12.1 -12.6 in ash-water mixtures.
Compacted Wastes (Baled and Boxed)	Paper 24%, Plastic 37%, Rubber 7%, Cotton 4%, Metal 15%, other organics 3%, other inorganics 10% (all % by volume).
Non-pro/Non-pro Drummed	Metal 33%, Inorganic and Organic Absorbent 14%, Paper 8%, Plastic 5%, Wood 7%, Cotton 3%, Rubber 2%, Glass 2%, Concrete 6%, Bitumen 1%, other inorganic materials 19% (all % by volume).
CANDECON Resin	Polystyrenedivinyl benzene (plus functional groups) copolymer IX resin, approximately 0.5 mm in diameter, containing EDTA and other chelating agents as well as corrosion inhibitor.
LL Resin/ALW Resin	Polystyrenedivinyl benzene (plus functional groups) copolymer IX resin.
ALW Sludge	Sludge containing a clay-based flocculant, comprised of a blend of clay minerals, polymers and pH adjusting agents. The sludge is mostly clay with a small (<10 wt%) polymer element
Moderator IX Resin	Polystyrenedivinyl benzene resin with sulfonic acid groups on the cation and quaternary ammonium groups on the anion. Generally the anion portion contains nitrate (37 g/L), carbonate and borate, while cation portions can contain up to 30 g/L of gadolinium. Resin contains approximately 40-50 wt% bound water.
PHT IX Resin/IX Columns	Polystyrenedivinyl benzene resin with sulfonic acid groups on the cation and quaternary ammonium groups on the anion. Generally the cation portion contains mostly iron and lithium, while the anion portion is mostly carbonate. Resin contains approximately 40-50 wt% bound water.
Miscellaneous IX Resin	Polystyrenedivinyl benzene (plus functional groups) copolymer IX resin, approximately 0.5 mm in diameter, sometimes containing granulated activated carbon and MACRONET polymer beads. Resin contains approximately 40-50 wt% bound water.
Core Components	Typically Inconel-600 or stainless steel (SS) 304L. PNGS SIR flux detector (cable and emitter) is 0.17 kg. PNGS "B" Vertical Flux Detector is 4.36 kg. PNGS "B" Horizontal Flux Detector is 5.85 kg.
Filters and Filter Elements	Stainless steel and carbon steel permanent vessels containing resin impregnated pleated paper, honeycomb-wound viscose elements, or epoxy impregnated fibreglass; also disposable filters containing sintered stainless steel woven wire mesh.
Pressure Tubes	Zr-2.5%Nb alloy. Approx weight of each is 61 kg.
End Fittings	Stainless steel (SS-403). Approx weight of each is 163 kg.
Calandria Tubes	Zircaloy-2. Approx. weight of each is 23 kg.
Calandria Tube Inserts	Stainless steel (SS-410). Approx weight of each is 1.2 kg.
Feeder Pipes	Carbon steel.
Heat Exchangers	Carbon steel shell, copper alloy tubes.
Steam Generators	Inconel 600 tubes, carbon steel shell and shroud, and head and tubesheet.

**Report**

<b>OPG Proprietary</b>		
Document Number:	<b>00216-REP-03902-00003</b>	Usage Classification:
		<b>INFORMATION</b>
Sheet Number:	Revision Number:	Page:
<b>N/A</b>	<b>R003</b>	<b>66 of 136</b>

Title:

**REFERENCE LOW- AND INTERMEDIATE-LEVEL WASTE INVENTORY FOR THE DEEP GEOLOGIC REPOSITORY**

**Table C.7: Physical Properties of Wastes**

Parameter	Bulk density (kg/m <sup>3</sup> )	Total porosity/void fraction (-)	Initial moisture content (kg water/kg waste)
Old Bottom Ash	680	na	0.01 (12)
Old Baghouse Ash	340	na	0.001
New Bottom Ash	550 (1)	0.3	0.01 (12)
New Baghouse Ash	390 (2)	0.3 (8)	0.001
Compacted Wastes - Boxes	1,000	0.5	0.001
Compacted Wastes - Bales	770	0.5	0.001
Non-processible – Drums	500	0.4 (9)	0.001 (10)
Non-processible – Boxes	227	0.9	0.001
Non-processible – Other	670(3) 3,290 (4)	0.9 (3) 0.2 (4)	0.001
LLW Resin	750(15)	0.42	0.44 - 0.48 (14)
ALW Sludge	1120	0.3	0.01 (11)
Steam Generators	1,250 – 1,740(5)	0.9 (5)	0.001
CANDECON Resin	850(15)	0.42	0.44 - 0.48 (14)
Moderator Resin	850(15)	0.42	0.44 - 0.48 (14)
PHT Resin	850(15)	0.42	0.44 - 0.48 (14)
Misc. Resin	850(15)	0.42	0.44 - 0.48 (14)
Irradiated Core Hardware	880 (6)	0.9	0.001
Filters and Elements	880 (6)	0.9	0.1 (13)
Retube Waste	970 (7)	0.9	0.001

**Notes:**

- (1) Based on 700 kg tare weight and 1.8 m<sup>3</sup> bin volume.
- (2) Based on 1000 kg tare weight and 1.8 m<sup>3</sup> bin volume.
- (3) Heat exchangers.
- (4) Encapsulated tile hole (included cement grout). Void space less due to grouting.
- (5) Steam generators to be segmented into pieces; shell side to be grouted prior to cutting; residual liquid to be drained from the tube side; exposed surfaces of segments covered with shield plates. Density and void space data exclude grout.
- (6) Based on containment in tile hole equivalent liners and tile hole liners.
- (7) Based on 160 kg per end fitting and 16 end fittings per box.
- (8) Finer constituents than bottom ash. Porosity of sand ranges from 0.2 to 0.4.
- (9) Contains granular fills and less void space.
- (10) Expect to be dry, but wet wastes are drummed.
- (11) Expect to be dry, since it is immobilised with polymer gel.
- (12) May contain some moisture as ash is doused (for cooling) during loading of bins. Some of the moisture may evaporate during storage.
- (13) Expect some moisture. Varies (>1% but <50%).
- (14) Bound (bead) water. Most free/interstitial water is drained from the resins during transfer to the resin liners at the stations.
- (15) Includes bound water.

OPG Proprietary		
Document Number:	00216-REP-03902-00003	Usage Classification: <b>INFORMATION</b>
Sheet Number:	Revision Number: R003	Page: 67 of 136

Title:

## REFERENCE LOW- AND INTERMEDIATE-LEVEL WASTE INVENTORY FOR THE DEEP GEOLOGIC REPOSITORY

### Appendix D: Uncertainties Associated with Concentrations of Radionuclides and Chemicals in Low- and Intermediate-Level Waste

A semi-quantitative assessment of the uncertainties associated with the radionuclide and chemical characteristics of various waste types is presented in this Appendix. The assessments in many instances refer to Log Dispersion (LD), which is defined as the Antilog of the standard deviation of the Log of the data. The dispersion serves as a measure of variability as it relates to the Log Mean (LM) value (also referred to as Geometric Mean). The LM is calculated as the Antilog of the average Log value. The assessments for gamma activity, scaling factors, reactor retube wastes, and chemical composition are detailed in Tables D.1 to D.4 respectively.

The significant findings are summarized below:

#### D.1.0 UNCERTAINTIES IN GAMMA ACTIVITY MEASUREMENTS

- Calculated container contact dose rates based on the specific activity data in Appendix B are consistent with or greater than the bulk of the measured dose rates on as-received packages (Table 4.3), indicating that the Appendix B values are representative of the waste with respect to gamma active nuclides. This includes the nuclides typically used as basis for the scaling factors.
- The gamma activity of the new baghouse ash is significantly lower than that of the old baghouse ash. Limited additional characterization is warranted.
- Data for baled waste are the underlying basis for deriving the gamma activity of compacted waste. Because box compaction employs higher forces than were employed during past baling operations, contents of box compacted waste differ somewhat from those of the bales.
- There is some uncertainty associated with gamma activity measurements of both boxed and drummed non-processible (NP) wastes. While gamma dose measurements are available for all packages, there are only a limited number of gamma spectroscopy measurements.
- In general, resin and sludge wastes are homogeneous compared to non-processible wastes. As such, their characterization needs are lower. However,
  - PHT and moderator resin data are based on Darlington's wastes. Pickering chemistry is controlled in much the same way as Darlington, so the characterization data is not expected to be significantly different. Absence of equivalent data for Bruce stations is a source of uncertainty, although CANDU reactors are generally operated with similar water chemistry.
  - Heavy water upgrader resins are exposed to both moderator and PHT heavy waters. This explains the significant dispersion (LD values) associated with Co-60 and Cs-137 activities for these "Misc." resins.

## Report

OPG Proprietary		
Document Number:	00216-REP-03902-00003	Usage Classification: <b>INFORMATION</b>
Sheet Number:	Revision Number: R003	Page: 68 of 136

Title:

### REFERENCE LOW- AND INTERMEDIATE-LEVEL WASTE INVENTORY FOR THE DEEP GEOLOGIC REPOSITORY

#### D.2.0 UNCERTAINTIES IN SCALING FACTOR MEASUREMENTS

- The gamma activity of the new baghouse ash is significantly lower than that of the old baghouse ash. Because of the different characteristics of baghouse ash from the new incinerator, additional characterization of DTM radionuclides is recommended.
- Scaling factors for NP wastes are largely based on characteristics of boxed wastes. Their applicability to the wide variety of drummed wastes is uncertain.
- The C-14/H-3 ratio for incinerable waste is used as the basis for estimating tritium inventories in various bulk LLW. While this approach is basically sound, its validity has not been directly confirmed.
- In general, scaling factor data for all resins and sludge are limited. Even though up to 30 PHT and 28 moderator resin samples have been analysed, most of the DTM radionuclide results are restricted to C-14.
- Data for Pu-241 in all waste types are limited. There are limited data for I-129, Cl-36 and Tc-99 in PHT, heavy water upgrader and moderator resins, but these are supplemented by model-based estimates. Their concentrations in other wastes are expected to be insignificant.

#### D.3.0 UNCERTAINTIES ASSOCIATED WITH REACTOR REFURBISHMENT WASTE ACTIVITIES

- Activities from retube wastes are based on ORIGEN-S calculations. ORIGEN calculates radionuclides to within a factor of 3 in general, with actinides much more accurately and Zr and Nb within 30% for a specific irradiation history. There is also indications that the ORIGEN results are generally higher than actual retube inventories (Aydogdu et al 1989).
- ORIGEN results for activated impurities are sensitive to assumed impurity levels. For example, Co-60 will be related to the amount of Co impurity in the pressure tube. The Pickering B ORIGEN calculations assume 0.3 ppm impurity, while measurements of Co in 6 Zr-Nb samples indicated < 5 ppm. Inventory calculations for impurity-based species such as Co-60 will therefore be less accurate. The results for the important Zr and Nb radionuclides, however, depend on the base alloy content and are therefore not sensitive to impurities.
- This report uses the ORIGEN results for an average channel from Bruce A Units 1 and 2 (assuming 25 years operation at 100% capacity factor), Bruce A Units 3 and 4 (assuming 100% capacity factor from in-service date to 2008, and 92.5% capacity factor from 2008 to planned refurbishment shutdown), Pickering B (assuming 25 years operation at 100% capacity factor), and Darlington (assuming 22 years operation at 90% capacity factor and 100% capacity for the



## Report

OPG Proprietary		
Document Number:	00216-REP-03902-00003	Usage Classification: <b>INFORMATION</b>
Sheet Number:	Revision Number: <b>R003</b>	Page: <b>69 of 136</b>

Title:

### **REFERENCE LOW- AND INTERMEDIATE-LEVEL WASTE INVENTORY FOR THE DEEP GEOLOGIC REPOSITORY**

remaining 3 years). Inventories will likely be less than calculated as the actual irradiation duration will likely be less than assumed.

#### **D.4.0 UNCERTAINTIES IN CHEMICAL COMPOSITIONS**

- The uncertainty in the composition in the old baghouse ash cannot be assessed because of limited data.
- The element compositions of baled and compacted wastes are inferred from the element composition of ash.
- Due to their heterogeneous nature, the composition of non-processible wastes are subject to some uncertainty. The designated hazardous materials of asbestos, lead, mercury, cadmium, uranium, beryllium, arsenic, and PCBs were conservatively estimated based on plausible sources in station waste, information contained in WWMF radioactive waste notification forms, and information obtained from PNGS personnel.
- The composition of filters and filter elements is based on an assumed distribution of disposed filter types.
- In general, composition data for various types of resins are well developed.
- The element compositions do not generally add up to 100% as common elements (especially C, H, O, N) are not routinely measured.

OPG Proprietary		
Document Number:	00216-REP-03902-00003	Usage Classification: <b>INFORMATION</b>
Sheet Number:	Revision Number: <b>R003</b>	Page: <b>70 of 136</b>

Title:

**REFERENCE LOW- AND INTERMEDIATE-LEVEL WASTE INVENTORY FOR THE DEEP GEOLOGIC REPOSITORY**

Table D.1: Uncertainties Associated with Gamma Activity Measurements

Waste Stream	Uncertainty in Measurement Data
Bottom Ash (old)	<ul style="list-style-type: none"> <li>Data based on sampled ash.</li> <li>LD &lt; 5 for most nuclides.</li> </ul>
Bottom Ash (new)	<ul style="list-style-type: none"> <li>Data based on 7 samples.</li> <li>Similar characteristics as old bottom ash.</li> <li>LD &lt; 5 for most nuclides.</li> </ul>
Baghouse Ash (old)	<ul style="list-style-type: none"> <li>Data based mostly on sampled ash; 3 drums assayed also.</li> <li>LD &lt; 5 for most nuclides.</li> </ul>
Baghouse Ash (new)	<ul style="list-style-type: none"> <li>Data based on 7 samples.</li> <li>Characteristics differ significantly from old baghouse ash.</li> <li>LD &lt; 5 for most nuclides.</li> </ul>
Baled Waste	<ul style="list-style-type: none"> <li>Data based on assay of several bales.</li> <li>LD &lt; 5 for most nuclides.</li> </ul>
Compacted Waste	<ul style="list-style-type: none"> <li>Data based on assay results for bales; 7 compactor boxes also assayed.</li> <li>LD &lt; 5 for most nuclides.</li> </ul>
Non-processible (Boxes)	<ul style="list-style-type: none"> <li>Data based on assay results for several bags; 85 boxes also assayed.</li> <li>LD &lt; 5 for most nuclides.</li> </ul>
Non-processible Drummed	<ul style="list-style-type: none"> <li>Data based on assay results for 100 drums and dose rate data for 100 drums.</li> <li>LD &gt; 5 for dessicant, glass, hose, metals, miscellaneous, concrete, core samples, filters, solidified aqueous wastes.</li> <li>LD &lt; 5 for bagged waste, eddy current probes, floor sweeping compound, sludge/aquaset, solidified oil, solidified sludge.</li> </ul>
CANDECON cation resin	<ul style="list-style-type: none"> <li>Data based on several resin samples.</li> <li>LD values for Co-60 and Cs-137 are &lt; 5.</li> </ul>
CANDECON mixed bed resin	<ul style="list-style-type: none"> <li>Data based on several resin samples.</li> <li>LD values for Co-60 and Cs-137 are &lt; 5.</li> </ul>
LLW Resin/ALW Resin	<ul style="list-style-type: none"> <li>Data based on several resin samples.</li> <li>LD values for Co-60 and Cs-137 are &lt; 5.</li> </ul>
ALW Sludge	<ul style="list-style-type: none"> <li>Data based on 4 sludge samples.</li> <li>LD values for Co-60 and Cs-137 are 6 and 23 respectively.</li> </ul>
PHT IX Resin	<ul style="list-style-type: none"> <li>Data based on several resin samples.</li> <li>LD values for Co-60 and Cs-137 are &lt; 5.</li> </ul>
Moderator IX Resin	<ul style="list-style-type: none"> <li>Data based on several resin samples.</li> <li>LD values for Co-60 and Cs-137 are &lt; 5.</li> </ul>
Miscellaneous IX Resin	<ul style="list-style-type: none"> <li>Data based on 7 resin samples.</li> <li>LD values for Co-60 and Cs-137 are 45 and 87 respectively.</li> </ul>
Filters	<ul style="list-style-type: none"> <li>Data based on 4 samples from fuelling machine filters.</li> <li>LD value for Co-60 is &lt; 5.</li> </ul>

OPG Proprietary		
Document Number:	00216-REP-03902-00003	Usage Classification: <b>INFORMATION</b>
Sheet Number: N/A	Revision Number: R003	Page: 71 of 136

Title:

**REFERENCE LOW- AND INTERMEDIATE-LEVEL WASTE INVENTORY FOR THE DEEP GEOLOGIC REPOSITORY**

Table D.2: Uncertainties Associated with Scaling Factor Measurements

Waste Stream	Uncertainty in Scaling Factors (SF)
Bottom Ash (old)	<ul style="list-style-type: none"> <li>SFs based on up to 20 samples.</li> <li>LD values are generally &lt; 5; LD value for Ni-63 ~10.</li> <li>Pu-241 based on 1 measurement.</li> </ul>
Bottom Ash (new)	<ul style="list-style-type: none"> <li>SFs based on 3 samples.</li> <li>LD values are generally &lt; 5.</li> <li>LD for C-14 and Sr-90 exceed 5.</li> </ul>
Baghouse Ash (old)	<ul style="list-style-type: none"> <li>SFs based on up to 10 samples.</li> <li>LD values are generally &lt; 5.</li> <li>Pu-241 based on 1 measurement.</li> </ul>
Baghouse Ash (new)	<ul style="list-style-type: none"> <li>SFs based on 3 samples.</li> <li>LD values generally &lt; 5.</li> <li>LD values for C-14, Fe-55 and Ni-63 exceed 5.</li> </ul>
Compact Bales	See box compacted waste.
Box Compacted	<ul style="list-style-type: none"> <li>SFs based on up to 25 samples.</li> <li>LD values for Pu-239/240, C-14, Ni-63, Sr-90 are 5-10.</li> <li>LD values for other nuclides are &lt; 5.</li> </ul>
Non-processible (Boxes)	<ul style="list-style-type: none"> <li>SFs based on up to 20 samples.</li> <li>LD values for Pu-239/240, C-14 and Sr-90 are 5-10.</li> <li>LD values for other nuclides are &lt; 5.</li> </ul>
Non-processible Drummed	<ul style="list-style-type: none"> <li>SFs based on up to 8 samples.</li> <li>LD values for Pu-239/240 and Fe-55 are 5-10.</li> <li>LD values for other nuclides are &lt; 5.</li> </ul>
CANDECON cation resin	1 sample.
CANDECON mixed bed resin	1 sample.
LL Resin/ALW Resin	<ul style="list-style-type: none"> <li>SF data available only for C-14 (11 samples).</li> <li>LD value for C-14 is 5-10.</li> </ul>
ALW Sludge	SF data available only for C-14 (1 sample).
PHT IX Resin	<ul style="list-style-type: none"> <li>SFs based on 30 samples.</li> <li>LD values are generally &lt; 5.</li> <li>LD values for Fe-55 and Am-241 are 5-10.</li> </ul>
Moderator IX Resin	<ul style="list-style-type: none"> <li>SFs based on up to 28 samples.</li> <li>Insufficient data to estimate LD values for Sr-90.</li> </ul>
Miscellaneous IX Resin	<ul style="list-style-type: none"> <li>SFs based on up to 7 samples.</li> <li>LD values for Pu-239/240, Ni-63 and Sr-90 are 5-10.</li> <li>LD values for other nuclides are &lt; 5.</li> <li>1 measurement for I-129.</li> </ul>
Filters	<ul style="list-style-type: none"> <li>SFs based on 2 samples from fuelling machines.</li> <li>LD values for C-14, Fe-55 and Ni-63 are &lt; 5.</li> </ul>

Report

OPG Proprietary		
Document Number:	00216-REP-03902-00003	Usage Classification: <b>INFORMATION</b>
Sheet Number:	Revision Number: R003	Page: 72 of 136

Title:

**REFERENCE LOW- AND INTERMEDIATE-LEVEL WASTE INVENTORY FOR THE DEEP GEOLOGIC REPOSITORY**

**Table D.3: Uncertainties Associated with Retube and Core Component Wastes**

Waste Stream	Uncertainty
General	<ul style="list-style-type: none"> <li>Inventories based on ORIGEN-S calculations.</li> <li>Actual irradiation duration likely less than assumed for calculations so inventories are likely conservative.</li> <li>5-year decay assumed from reactor shutdown to transfer to DGR.</li> </ul>
Pressure Tubes	<ul style="list-style-type: none"> <li>Comparison of ORIGEN-S calculations with measurements on Pickering Unit 2 PTs indicates agreement with factor of 1.5 for Mn-54, Zr-95, Nb-95, Sn-113, Sb-124, Hf-181; within factor of 3 for Co-60 and Sb-125; and factor of 10 for Ta-182, with calculations always similar to or larger than measured (Aydogdu et al. 1989).</li> <li>Zr-93 and Nb-94 inventory in this report is likely accurate to within factor of 3, and is likely overestimated.</li> <li>Actinide inventory (surface contamination) based on Pickering feeder pipe outlet data.</li> </ul>
End Fittings	Comparison of ORIGEN-S results with measured dose rates for Pickering Unit 2 end fittings showed agreement within factor of 2 at reactor side, and dropping off similar or faster in measurements than calculations (Aydogdu et al. 1989).
Calandria Tubes	See General.
Calandria Tube Inserts	See General.
Irradiated Core Components	Inventory based on ORIGEN calculations used for assessment/design of transport package.

**Table D.4: Uncertainties Associated with Chemical Composition Measurements**

Waste Stream	Uncertainty in Chemical Composition
Bottom Ash (old)	<ul style="list-style-type: none"> <li>Element composition based on more than 5 samples.</li> <li>LD values for all elements are &lt; 5.</li> <li>Data on organics based on 3 samples. Uncertainty for PAH high (LD ~10); uncertainty for other organics low (LD &lt; 5).</li> </ul>
Bottom Ash (new)	<ul style="list-style-type: none"> <li>Element composition based on 8 samples.</li> <li>LD values for most elements are &lt; 5.</li> <li>Organics data based on 3 composite samples.</li> </ul>
Baghouse Ash (old)	<ul style="list-style-type: none"> <li>Element composition based on 1 sample.</li> <li>Organics data based on 1 sample.</li> </ul>
Baghouse Ash (new)	<ul style="list-style-type: none"> <li>Element composition based on 8 samples.</li> <li>LD values for most elements are &lt; 5.</li> <li>Organics data based on 3 composite samples.</li> </ul>
Compact Bales	<ul style="list-style-type: none"> <li>Element composition (Table C.1) assumed same as ash.</li> <li>Physical composition (Table C.6) based on principal materials present in the waste.</li> </ul>
Box Compacted	<ul style="list-style-type: none"> <li>Element composition assumed same as ash.</li> <li>Physical composition based on principal materials present in the 'old' compacted waste. Physical composition of the 'new' compacted waste has not been quantified; metal content is expected to be higher than that present in baled waste.</li> </ul>

Report

OPG Proprietary		
Document Number:	00216-REP-03902-00003	Usage Classification: <b>INFORMATION</b>
Sheet Number:	Revision Number: R003	Page: 73 of 136

Title:

**REFERENCE LOW- AND INTERMEDIATE-LEVEL WASTE INVENTORY FOR THE DEEP GEOLOGIC REPOSITORY**

Waste Stream	Uncertainty in Chemical Composition
Non-processible (Boxes)	<ul style="list-style-type: none"> <li>Physical composition based on principal materials present in the waste has been quantified (several bags examined); however, significant variability from mean composition is expected because of the heterogeneity of the waste stream.</li> <li>Element composition deduced from an estimated mean composition for boxed and drummed non-processible wastes. This composition is uncertain.</li> <li>Hazardous metals and elements were conservatively estimated.</li> </ul>
Non-processible (Drummed)	<ul style="list-style-type: none"> <li>Physical composition based on principal contents of 200 drums has been quantified; however, significant variability from mean composition is expected because of the heterogeneity of the waste stream.</li> <li>Elemental composition data deduced from an estimated mean composition for boxed and drummed non-processible wastes.</li> </ul>
CANDECON cation resin	<ul style="list-style-type: none"> <li>Element composition based on one sample.</li> <li>However, such data have also been estimated from plant data measured during the decontaminations. Overall reagent loadings on combined cation and mixed bed resins are reasonably well known.</li> <li>Uncertainty for most elements is expected to be within a factor of 5.</li> </ul>
CANDECON mixed bed resin	<ul style="list-style-type: none"> <li>Element composition based on one sample.</li> <li>However, such data have also been estimated from plant data measured during the decontaminations. Overall reagent loadings on combined cation and mixed bed resins are reasonably well known.</li> <li>Uncertainty for most elements is expected to be within a factor of 5.</li> </ul>
LL Resin/ALW Resin	<ul style="list-style-type: none"> <li>Element composition based on 8 samples.</li> <li>LD values for most elements are &lt; 5.</li> </ul>
ALW Sludge	<ul style="list-style-type: none"> <li>Element composition based on 3 samples.</li> <li>LD values for most elements are &lt; 5.</li> </ul>
PHT IX Resin	<ul style="list-style-type: none"> <li>Element composition based on 28 samples.</li> <li>LD values for most elements are &lt; 5.</li> </ul>
Moderator IX Resin	<ul style="list-style-type: none"> <li>Element composition based on 21 samples.</li> <li>LD values for most elements are &lt; 5.</li> </ul>
Miscellaneous IX Resin	<ul style="list-style-type: none"> <li>Element composition based on 4 samples.</li> <li>LD values for most elements are &lt; 5.</li> </ul>
Filters	<ul style="list-style-type: none"> <li>Composition based on average physical composition for various filter types used at stations.</li> <li>Actual filter usage (i.e., relative amounts of each type) is uncertain.</li> </ul>
Steam Generators, Heat Exchangers	Composition based on primary metal types used for shell and tube side.

**Report**

OPG Proprietary		
Document Number:	00216-REP-03902-00003	Usage Classification:
Sheet Number:	Revision Number:	Page:
N/A	R003	74 of 136

Title:

**REFERENCE LOW- AND INTERMEDIATE-LEVEL WASTE INVENTORY FOR THE DEEP GEOLOGIC REPOSITORY****Appendix E: Reference Deep Geological Repository Data Sheets**

The following container datasheets provide descriptions of the reference containers and shield packages for transfer to the DGR. Note that some waste types are also stored in other containers. Note also that the waste properties and container forecast given on the datasheets are nominal, and the main report provides the reference forecasts. Also gross volumes are from the container catalog and may be rounded upwards.

**Existing storage containers:**

- AIBO2 – old style ash bin
- AIBN – new style ash bin\*
- BRACK – bale rack
- B25 – green bin compactor box\*
- NPB4 – 4 high stacking, old style non-pro blue bin
- NPB47 – 47", new style non-pro blue bin\*
- DRACK – old style drum rack
- DBIN – new style drum bin\*
- RB90 – old style LL resin box
- RTK – LL resin pallet tank\*
- NPBSB – ALW sludge box\*
- SPC – shield plug box
- HX – heat exchanger (from IC-HX)
- ETH – encapsulated tile hole
- RL/RLSS – 3m<sup>3</sup> resin liner; RLSS is current stainless steel liner
- RLOPK – resin liner overpack for old RL carbon steel liners
- THLSTG3 – tile-hole-liner
- RWC(EF) – retube end-fitting box\*
- RWC(PT) – retube pressure tube box\*

**Future deep geological repository specific containers:**

- BINOPK – LLW container overpack for AIBO2, AIBN, RB90, NPBSB, and DRACK containers.
- RLSHLD – 3m<sup>3</sup> resin liner shield container (for RL and RLSS, 1 or 2 liners per shield).
- ATHELHLD – tile-hole-equivalent container shield (for ATHEL, one per shield).
- SGSGMT – Steam generator segment (cut up SG).
- ILWSHLD – ILW shield (replacement for tile-hole-equivalent IC-18).

\* default container for waste arisings 2006 onwards.

Report

OPG Proprietary		
Document Number:	00216-REP-03902-00003	Usage Classification: <b>INFORMATION</b>
Sheet Number:	Revision Number:	Page:
N/A	R003	75 of 136

Title:

**REFERENCE LOW- AND INTERMEDIATE-LEVEL WASTE INVENTORY FOR THE DEEP  
GEOLOGIC REPOSITORY**

**This page has been left  
blank intentionally.**

Report

OPG Proprietary		
Document Number:	Usage Classification:	
<b>00216-REP-03902-00003</b>	<b>INFORMATION</b>	
Sheet Number:	Revision Number:	Page:
<b>N/A</b>	<b>R003</b>	<b>76 of 136</b>

Title:

**REFERENCE LOW- AND INTERMEDIATE-LEVEL WASTE INVENTORY FOR THE DEEP GEOLOGIC REPOSITORY**

<b>Container Description</b>	<p>Container name: Ash Bin (Old)*          IWTS container code: AIBO2          CATID: 216422          Dimensions (m): 2.29 L x 1.22 W x 1.47 H          External surface area (m<sup>2</sup>): 15.9          Gross volume (m<sup>3</sup>): 4.2          Net volume (m<sup>3</sup>): 3.4          Material: Galvanized mild steel, 2.6 mm thick (12 ga.)          Empty mass (kg): 681          Max gross mass (kg): 2,950          Stackability: 5 high          Handling: Forklift pockets</p>													
<b>Waste Properties</b>	<p>Typical contents: Incinerated incinerable waste          Typical composition: Bottom ash          Potential hazardous constituents: Dioxins, furans, chlorinated benzenes, PCBs, PAHs          Avg waste density (kg/m<sup>3</sup>): 680          Contact Dose rate (mSv/h): &lt;0.01: 9.5%; 0.01-0.05: 5.6%; 0.05-0.10: 14.7%; 0.10-0.20: 25.4%; 0.20-0.50: 38.1%; 0.50-1: 5.0%; 1-2: 1.3%; 2-10: 0.4%; &gt;10: 0.0%          Specific activity (Bq/m<sup>3</sup>): 2.0E+09</p>													
<b>Forecast Inventory*</b>	<table border="1"> <thead> <tr> <th></th> <th>To 2018</th> <th>To 2052</th> </tr> </thead> <tbody> <tr> <td>Number of containers**:</td> <td>296</td> <td>296</td> </tr> <tr> <td>Total gross volume (m<sup>3</sup>):</td> <td>1,253</td> <td>1,253</td> </tr> <tr> <td>Total net volume (m<sup>3</sup>):</td> <td>950</td> <td>950</td> </tr> </tbody> </table>		To 2018	To 2052	Number of containers**:	296	296	Total gross volume (m <sup>3</sup> ):	1,253	1,253	Total net volume (m <sup>3</sup> ):	950	950	
	To 2018	To 2052												
Number of containers**:	296	296												
Total gross volume (m <sup>3</sup> ):	1,253	1,253												
Total net volume (m <sup>3</sup> ):	950	950												
<b>Ref</b>	Dwg # n/a													

\* Entire forecast inventory to be packaged in LLW container overpacks (BINOPK).

\*\* Totals include Drum Rack (Old) with ash.



**Report**

<b>OPG Proprietary</b>		
Document Number: <b>00216-REP-03902-00003</b>		Usage Classification: <b>INFORMATION</b>
Sheet Number: <b>N/A</b>	Revision Number: <b>R003</b>	Page: <b>77 of 136</b>

Title:

**REFERENCE LOW- AND INTERMEDIATE-LEVEL WASTE INVENTORY FOR THE DEEP GEOLOGIC REPOSITORY**

no drawing available

Report

OPG Proprietary		
Document Number:	00216-REP-03902-00003	Usage Classification: <b>INFORMATION</b>
Sheet Number:	Revision Number: R003	Page: 78 of 136

Title:

**REFERENCE LOW- AND INTERMEDIATE-LEVEL WASTE INVENTORY FOR THE DEEP GEOLOGIC REPOSITORY**

Container Description	Container name: Ash Bin (New)* IWTS container code: AIBN CATID: 576616 Dimensions (m): 1.32 L x 1.32 W x 1.40 H External surface area (m <sup>2</sup> ): 10.9 Gross volume (m <sup>3</sup> ): 2.5 Net volume (m <sup>3</sup> ): 1.8 Material: Hot dip. galvanized carbon steel, 3.4 mm thick (10 ga.) Empty mass (kg): 380 Max gross mass (kg): 1,604 Stackability: 4 high Handling: Forklift pockets		
	Waste Properties	Typical contents: Incinerated incinerable waste Typical composition: Bottom ash, baghouse ash Potential hazardous constituents: Dioxins, furans, chlorinated benzenes, PCBs, PAHs Avg waste density (kg/m <sup>3</sup> ): 550 (bottom ash), 390 (baghouse ash) Contact Dose rate (mSv/h): <0.01: 9.5%; 0.01-0.05: 5.6%; 0.05-0.10: 14.7%; 0.10-0.20: 25.4%; 0.20-0.50: 38.1%; 0.50-1: 5.0%; 1-2: 1.3%; 2-10: 0.4%; >10: 0.0% Specific activity (Bq/m <sup>3</sup> ): 1.3E+10	
Forecast Inventory		<b>To 2018</b>	<b>To 2052</b>
	Number of containers:	373	804
	Total gross volume (m <sup>3</sup> ):	933	2,010
	Total net volume (m <sup>3</sup> ):	671	1,447
Ref	Dwg # 0125-DRAW-79710-10300		

\* Entire forecast inventory to be packaged in LLW container overpacks (BINOPK).

Report

<b>OPG Proprietary</b>		
Document Number:	<b>00216-REP-03902-00003</b>	Usage Classification:
		<b>INFORMATION</b>
Sheet Number:	Revision Number:	Page:
<b>N/A</b>	<b>R003</b>	<b>79 of 136</b>

Title:

**REFERENCE LOW- AND INTERMEDIATE-LEVEL WASTE INVENTORY FOR THE DEEP GEOLOGIC REPOSITORY**

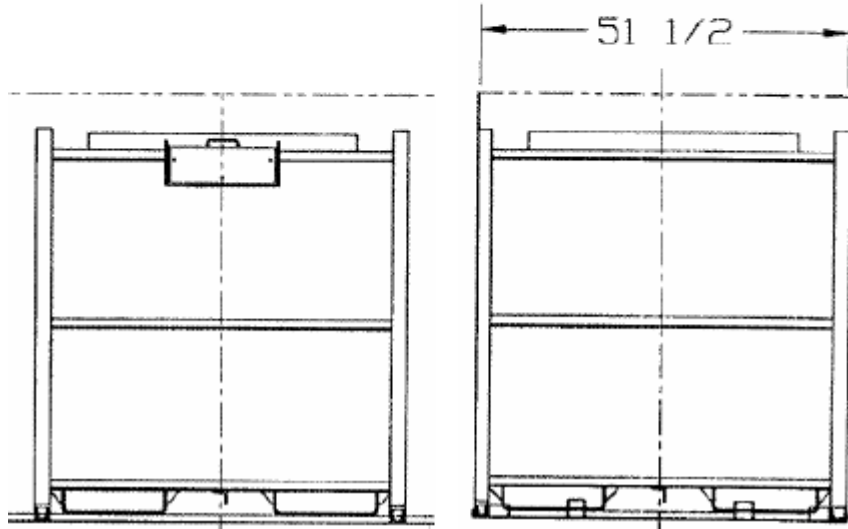
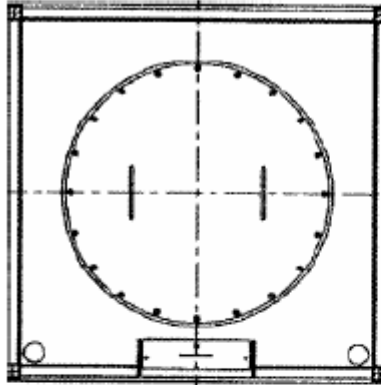

Report

OPG Proprietary		
Document Number:	00216-REP-03902-00003	Usage Classification: <b>INFORMATION</b>
Sheet Number:	Revision Number: R003	Page: 80 of 136

Title:

**REFERENCE LOW- AND INTERMEDIATE-LEVEL WASTE INVENTORY FOR THE DEEP GEOLOGIC REPOSITORY**

<b>Container Description</b>	<p>Container name: Bale Rack</p> <p>IWTS container code: BRACK</p> <p>CATID: 216420</p> <p>Dimensions (m): 2.29 L x 1.22 W x 1.2 H</p> <p>External surface area (m<sup>2</sup>): 14</p> <p>Gross volume (m<sup>3</sup>): 3.4</p> <p>Net volume (m<sup>3</sup>): 1.64</p> <p>Material: Painted mild steel, open slides</p> <p>Empty mass (kg): 150</p> <p>Max gross mass (kg): n/a</p> <p>Stackability: 5 high</p> <p>Handling: Forklift pockets</p>													
<b>Waste Properties</b>	<p>Typical contents: Low-force compacted compressible low level waste</p> <p>Typical composition: 24% paper, 37% plastic, 7% rubber, 4% cotton, 15% metal, 3% other Organics, 10% other inorganics</p> <p>Potential hazardous constituents: Cadmium, mercury, lead, and other heavy metals</p> <p>Avg waste density (kg/m<sup>3</sup>): 766</p> <p>Contact Dose rate (mSv/h): &lt;0.01: 24.6%; 0.01-0.05: 25.4%; 0.05-0.10: 12.7%; 0.10-0.20: 9.7%; 0.20-0.50: 11.6%; 0.50-1: 7.5%; 1-2: 4.9%; 2-10: 3.1%; &gt;10: 0.4%</p> <p>Specific activity (Bq/m<sup>3</sup>): 2.3E+11</p>													
<b>Forecast Inventory</b>	<table border="1"> <thead> <tr> <th></th> <th>To 2018</th> <th>To 2052</th> </tr> </thead> <tbody> <tr> <td>Number of containers:</td> <td>1,383</td> <td>1,383</td> </tr> <tr> <td>Total gross volume (m<sup>3</sup>):</td> <td>4,702</td> <td>4,702</td> </tr> <tr> <td>Total net volume (m<sup>3</sup>):</td> <td>2,268</td> <td>2,268</td> </tr> </tbody> </table>		To 2018	To 2052	Number of containers:	1,383	1,383	Total gross volume (m <sup>3</sup> ):	4,702	4,702	Total net volume (m <sup>3</sup> ):	2,268	2,268	
	To 2018	To 2052												
Number of containers:	1,383	1,383												
Total gross volume (m <sup>3</sup> ):	4,702	4,702												
Total net volume (m <sup>3</sup> ):	2,268	2,268												
<b>Ref</b>	Dwg # 0125-DXX-79160-0002 (rack identical to drum rack and holds 4 bales)													

**Report**

<b>OPG Proprietary</b>		
Document Number: <b>00216-REP-03902-00003</b>		Usage Classification: <b>INFORMATION</b>
Sheet Number: <b>N/A</b>	Revision Number: <b>R003</b>	Page: <b>81 of 136</b>

Title:

**REFERENCE LOW- AND INTERMEDIATE-LEVEL WASTE INVENTORY FOR THE DEEP GEOLOGIC REPOSITORY**

drawing similar to drum rack

Report

OPG Proprietary		
Document Number:	00216-REP-03902-00003	Usage Classification: <b>INFORMATION</b>
Sheet Number:	Revision Number: R003	Page: 82 of 136

Title:

**REFERENCE LOW- AND INTERMEDIATE-LEVEL WASTE INVENTORY FOR THE DEEP GEOLOGIC REPOSITORY**

<b>Container Description</b>	<p>Container name: Compactor box ("green bin")</p> <p>IWTS container code: B25</p> <p>CATID: 215982</p> <p>Dimensions (m): 1.84 L x 1.12 W x 1.3 H</p> <p>External surface area (m<sup>2</sup>): 11.8</p> <p>Gross volume (m<sup>3</sup>): 2.8</p> <p>Net volume (m<sup>3</sup>): 2.3</p> <p>Material: Painted mild steel, 4.6 mm thick (7 ga.)</p> <p>Empty mass (kg): 486</p> <p>Max gross mass (kg): 2,722</p> <p>Stackability: 5 high</p> <p>Handling: Forklift pockets</p>		
	<p>Typical contents: Low-force compacted compressible low level waste</p> <p>Typical composition: 24% paper, 37% plastic, 7% rubber, 4% cotton, 15% metal, 3% other organics, 10% other inorganics</p> <p>Potential hazardous constituents: Cadmium, mercury, lead, and other heavy metals</p> <p>Avg waste density (kg/m<sup>3</sup>): 1,000</p> <p>Contact Dose rate (mSv/h): &lt;0.01: 57.9%; 0.01-0.05: 26.8% 0.05-0.10: 8.8%; 0.10-0.20: 3.4%; 0.20-0.50: 1.7%; 0.50-1: 0.8%; 1-2: 0.5%; 2-10: 0.1%; &gt;10: 0.0%</p> <p>Specific activity (Bq/m<sup>3</sup>): 2.8E+11</p>		
<b>Forecast Inventory</b>		<b>To 2018</b>	<b>To 2052</b>
	Number of containers:	4,490	6,135
	Total gross volume (m <sup>3</sup> ):	12,573	17,177
	Total net volume (m <sup>3</sup> ):	10,328	14,110
<b>Ref</b>	Dwg # 01098-DDX-79165-0001		

Report

<b>OPG Proprietary</b>		
Document Number:	<b>00216-REP-03902-00003</b>	Usage Classification:
		<b>INFORMATION</b>
Sheet Number:	Revision Number:	Page:
<b>N/A</b>	<b>R003</b>	<b>83 of 136</b>

Title:

**REFERENCE LOW- AND INTERMEDIATE-LEVEL WASTE INVENTORY FOR THE DEEP GEOLOGIC REPOSITORY**

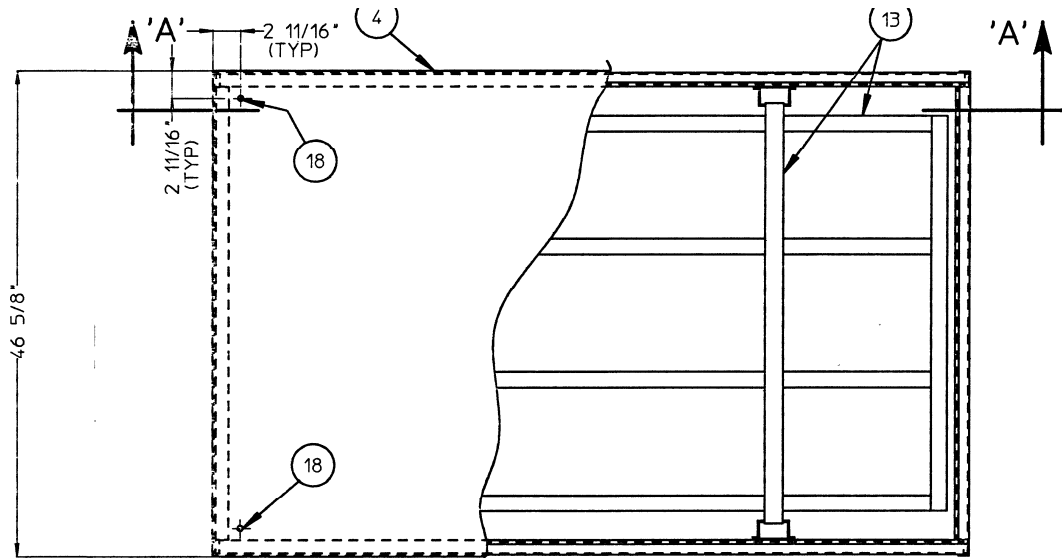

**PLAN VIEW P1**

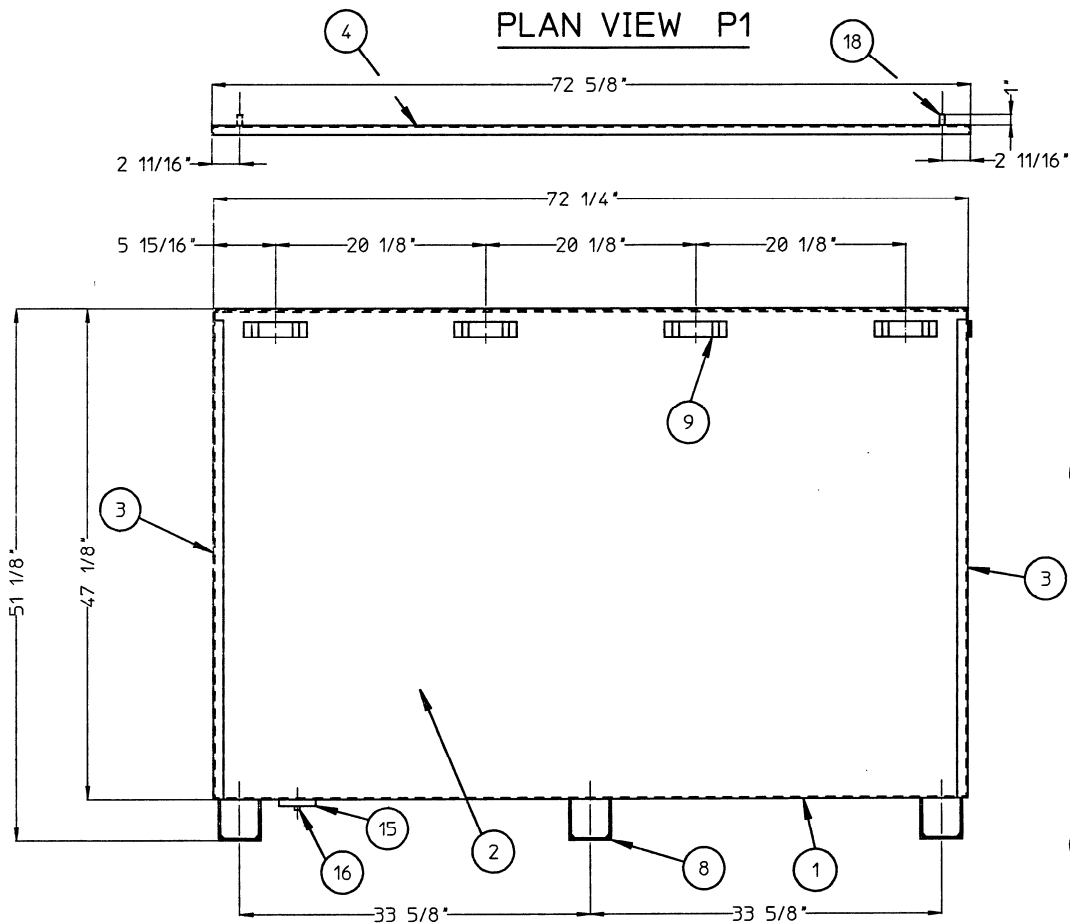

Report

OPG Proprietary		
Document Number:	00216-REP-03902-00003	Usage Classification: <b>INFORMATION</b>
Sheet Number:	Revision Number: R003	Page: 84 of 136

Title:

**REFERENCE LOW- AND INTERMEDIATE-LEVEL WASTE INVENTORY FOR THE DEEP GEOLOGIC REPOSITORY**

<b>Container Description</b>	<p>Container name: 4 High Non-Pro Bin</p> <p>IWTS container code: NPB4</p> <p>CATID: 216421-4</p> <p>Dimensions (m): 2.3 L x 1.2 W x 1.5 H</p> <p>External surface area (m<sup>2</sup>): 15.9</p> <p>Gross volume (m<sup>3</sup>): 4.2</p> <p>Net volume (m<sup>3</sup>): 3.2</p> <p>Material: Painted mild steel, 3mm thick (11 ga.)</p> <p>Empty mass (kg): 340</p> <p>Max gross mass (kg): 1,066</p> <p>Stackability: 4 high</p> <p>Handling: Forklift pockets</p>		
	<p>Typical contents: Non-processible waste comprised of IX columns, scaffolding, piping, shavings, angle irons, etc.</p> <p>Typical composition: 33% metal, 14% absorbent, 8% paper, 5% plastics, 5% wood, 3% cotton, 2% rubber, 5% glass, 6% concrete, 19% other</p> <p>Potential hazardous constituents: Some non-pro contains asbestos from insulation and gasket material, and some contains lead (batteries and shielding), cadmium/lithium (batteries) and mercury (relays and fluorescent tubes)</p> <p>Avg waste density (kg/m<sup>3</sup>): 227</p> <p>Contact Dose rate (mSv/h): &lt;0.01: 64.1%; 0.01-0.05: 15.5%; 0.05-0.10: 6.9%; 0.10-0.20: 3.7%; 0.20-0.50: 4.5%; 0.50-1: 2.0%; 1-2: 1.2%; 2-10: 1.9%; &gt;10: 0.2%</p> <p>Specific activity (Bq/m<sup>3</sup>): 3.0E+10</p>		
<b>Forecast Inventory</b>		<b>To 2018</b>	<b>To 2052</b>
	Number of containers*:	9,659	10,211
	Total gross volume (m <sup>3</sup> ):	27,563	28,833
	Total net volume (m <sup>3</sup> ):	20,534	21,683
<b>Ref</b>	Dwg # 0125-DXH-79160-0004		

\* Includes other smaller non-processible container designs.



Report

<b>OPG Proprietary</b>		
Document Number: <b>00216-REP-03902-00003</b>	Usage Classification: <b>INFORMATION</b>	
Sheet Number: <b>N/A</b>	Revision Number: <b>R003</b>	Page: <b>85 of 136</b>

Title:  
**REFERENCE LOW- AND INTERMEDIATE-LEVEL WASTE INVENTORY FOR THE DEEP GEOLOGIC REPOSITORY**

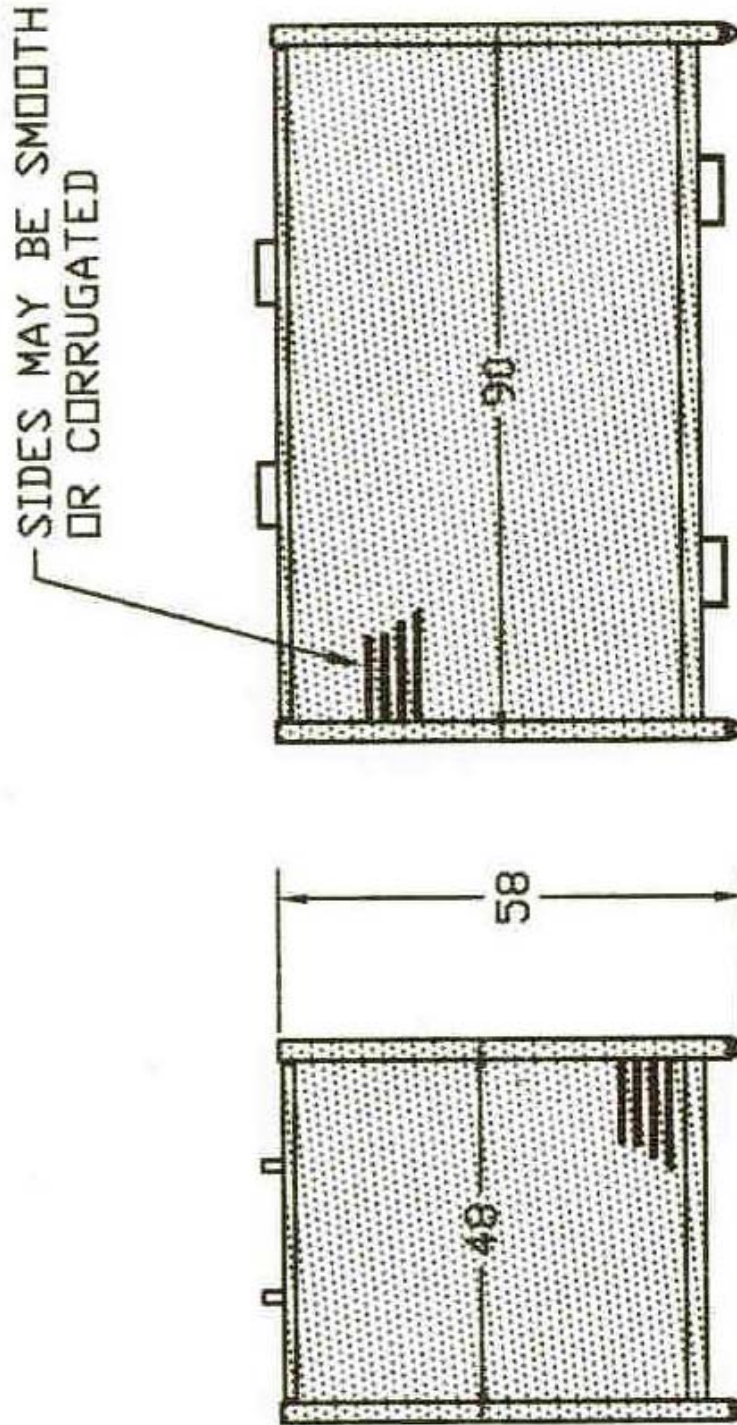

Report

OPG Proprietary		
Document Number:	00216-REP-03902-00003	Usage Classification: <b>INFORMATION</b>
Sheet Number:	N/A	Revision Number: R003
		Page: 86 of 136

Title:

**REFERENCE LOW- AND INTERMEDIATE-LEVEL WASTE INVENTORY FOR THE DEEP GEOLOGIC REPOSITORY**

<b>Container Description</b>	<p>Container name: Non-Pro Container (47" High)</p> <p>IWTS container code: NPB47</p> <p>CATID: 490723</p> <p>Dimensions (m): 1.96 L x 1.32 W x 1.19 H</p> <p>External surface area (m<sup>2</sup>): 13</p> <p>Gross volume (m<sup>3</sup>): 3.2</p> <p>Net volume (m<sup>3</sup>): 2.5</p> <p>Material: HSS (hollow structural section) frame with sheet metal sides and bottom (2.8 mm thick)</p> <p>Empty mass (kg): 360</p> <p>Max gross mass (kg): 1,460</p> <p>Stackability: 5 high</p> <p>Handling: Forklift pockets</p>		
	<p>Typical contents: Non-processible waste comprised of IX columns, scaffolding, piping, shavings, angle irons, etc.</p> <p>Typical composition: 3% metal, 14% absorbent, 8% paper, 5% plastics, 5% wood, 3% cotton, 2% rubber, 5% glass, 6% concrete, 19% other inorganic</p> <p>Potential hazardous constituents: Some non-pro contains asbestos from insulation and gasket material, and some contains lead (batteries and shielding), cadmium/lithium (batteries) and mercury (relays and fluorescent tubes)</p> <p>Avg waste density (kg/m<sup>3</sup>): 227</p> <p>Contact Dose rate (mSv/h): &lt;0.01: 64.1%; 0.01-0.05: 15.5%; 0.05-0.10: 6.9%; 0.10-0.20: 3.7%; 0.20-0.50: 4.5%; 0.50-1: 2.0%; 1-2: 1.2%; 2-10: 1.9%; &gt;10: 0.2%</p> <p>Specific activity (Bq/m<sup>3</sup>): 3.0E+10</p>		
<b>Forecast Inventory</b>		<b>To 2018</b>	<b>To 2052</b>
	Number of containers:	6,936	13,953
	Total gross volume (m <sup>3</sup> ):	22,195	44,650
	Total net volume (m <sup>3</sup> ):	17,340	34,883
<b>Ref</b>	Dwg # 01098-DRAW-79165-10003 sheet 0002		

Report

<b>OPG Proprietary</b>		
Document Number: <b>00216-REP-03902-00003</b>	Usage Classification: <b>INFORMATION</b>	
Sheet Number: <b>N/A</b>	Revision Number: <b>R003</b>	Page: <b>87 of 136</b>

Title:  
**REFERENCE LOW- AND INTERMEDIATE-LEVEL WASTE INVENTORY FOR THE DEEP GEOLOGIC REPOSITORY**

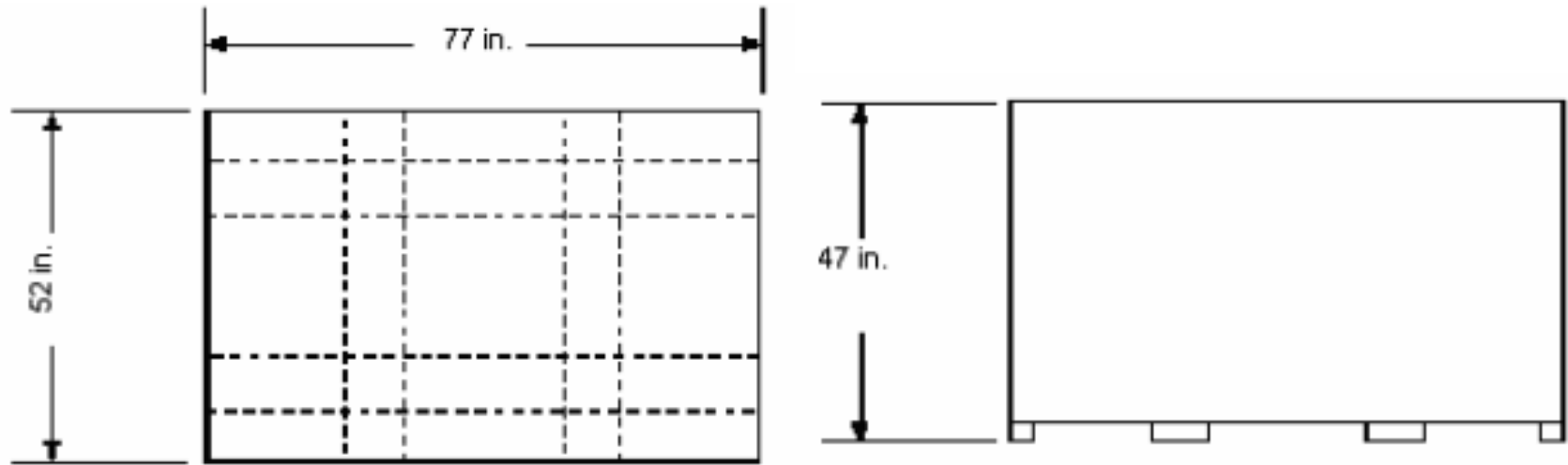

Report

OPG Proprietary		
Document Number:	00216-REP-03902-00003	Usage Classification: <b>INFORMATION</b>
Sheet Number:	Revision Number: R003	Page: 88 of 136

Title:

**REFERENCE LOW- AND INTERMEDIATE-LEVEL WASTE INVENTORY FOR THE DEEP GEOLOGIC REPOSITORY**

<b>Container Description</b>	<p>Container name: Drum Rack</p> <p>IWTS container code: DRACK</p> <p>CATID: 216420</p> <p>Dimensions (m): 2.29 L x 1.22 W x 1.2 H</p> <p>External surface area (m<sup>2</sup>): 2.8</p> <p>Gross volume (m<sup>3</sup>): 3.4</p> <p>Net volume (m<sup>3</sup>): 1.2 (based on 6 drums at 0.2 m<sup>3</sup> each)</p> <p>Material: Painted mild steel, open top and sides</p> <p>Empty mass (kg): 150 (excluding mass of drums)</p> <p>Max gross mass (kg): 1,490</p> <p>Stackability: 5 high</p> <p>Handling: Forklift pockets</p>		
	<p>Typical contents: Scrap metal (valves, motors), eddy current probes, shavings, etc.</p> <p>Typical composition: 33% metal, 14% absorbent, 8% paper, 5% plastics, 5% wood, 3% cotton, 2% rubber, 5% glass, 6% concrete, 19% other</p> <p>Potential hazardous constituents: Some non-pro contains asbestos from insulation and gasket material, and some contains lead (batteries and shielding), cadmium/lithium (batteries) and mercury (relays and fluorescent tubes)</p> <p>Avg waste density (kg/m<sup>3</sup>): 500</p> <p>Contact Dose rate (mSv/h): &lt;0.01: 70.7%; 0.01-0.05: 13.8%; 0.05-0.10: 4.9%; 0.10-0.20: 2.4%; 0.20-0.50: 2.2%; 0.50-1: 1.6%; 1-2: 1.0%; 2-10: 2.9%; &gt;10: 0.4%</p> <p>Specific activity (Bq/m<sup>3</sup>): 6.3E+11</p>		
<b>Forecast Inventory</b>		<b>To 2018</b>	<b>To 2052</b>
	Number of containers:	3,225	3,225
	Total gross volume (m <sup>3</sup> ):	10,965	10,965
	Total net volume (m <sup>3</sup> ):	3,870	3,870
<b>Ref</b>	Dwg # 0125-DXX-79160-0002		

Report

<b>OPG Proprietary</b>		
Document Number:	<b>00216-REP-03902-00003</b>	Usage Classification:
		<b>INFORMATION</b>
Sheet Number:	Revision Number:	Page:
<b>N/A</b>	<b>R003</b>	<b>89 of 136</b>

Title:  
**REFERENCE LOW- AND INTERMEDIATE-LEVEL WASTE INVENTORY FOR THE DEEP GEOLOGIC REPOSITORY**

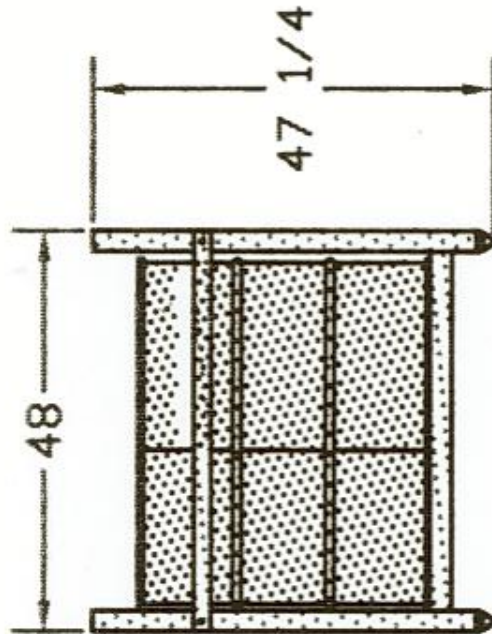
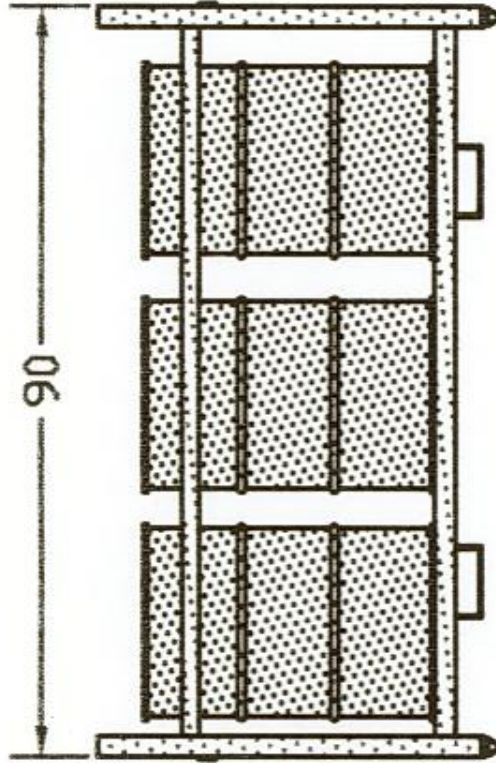

# Report

OPG Proprietary		
Document Number:	00216-REP-03902-00003	Usage Classification: <b>INFORMATION</b>
Sheet Number:	Revision Number: <b>R003</b>	Page: <b>90 of 136</b>

Title:

## REFERENCE LOW- AND INTERMEDIATE-LEVEL WASTE INVENTORY FOR THE DEEP GEOLOGIC REPOSITORY

<b>Container Description</b>	<p>Container name: Drum Bin</p> <p>IWTS container code: DBIN</p> <p>CATID: 402974</p> <p>Dimensions (m): 1.96 L x 1.32 W x 1.03 H</p> <p>External surface area (m<sup>2</sup>): 11.9</p> <p>Gross volume (m<sup>3</sup>): 2.8</p> <p>Net volume (m<sup>3</sup>): 1.2 (based on 6 drums at 0.2 m<sup>3</sup> each)</p> <p>Material: Hollow-structural-section carbon steel and sheet carbon steel (6.5 mm thick)</p> <p>Empty mass (kg): 290</p> <p>Max gross mass (kg): 1,450</p> <p>Stackability: 5 high</p> <p>Handling: Forklift pockets</p>		
	<p>Typical contents: Scrap metal (valves, motors), eddy current probes, shavings, etc.</p> <p>Typical composition: 33% metal, 14% absorbent, 8% paper, 5% plastics, 5% wood, 3% cotton, 2% rubber, 5% glass, 6% concrete, 19% other</p> <p>Potential hazardous constituents: Some non-pro contains asbestos from insulation and gasket material, and some contains lead (batteries and shielding), cadmium/lithium (batteries) and mercury (relays and fluorescent tubes)</p> <p>Avg waste density (kg/m<sup>3</sup>): 500</p> <p>Contact Dose rate (mSv/h): &lt;0.01: 70.7%; 0.01-0.05: 13.8%; 0.05-0.10: 4.9%; 0.10-0.20: 2.4%; 0.20-0.50: 2.2%; 0.50-1: 1.6%; 1-2: 1.0%; 2-10: 2.9%; &gt;10: 0.4%</p> <p>Specific activity (Bq/m<sup>3</sup>): 6.3E+11</p>		
<b>Forecast Inventory</b>		<b>To 2018</b>	<b>To 2052</b>
	Number of containers:	2,548	4,615
	Total gross volume (m <sup>3</sup> ):	7,133	12,922
	Total net volume (m <sup>3</sup> ):	3,057	5,538
<b>Ref</b>	Dwg # 01098-DRAW-79165-10005 sheet 0002		

Report

<b>OPG Proprietary</b>		
Document Number: <b>00216-REP-03902-00003</b>	Usage Classification: <b>INFORMATION</b>	
Sheet Number: <b>N/A</b>	Revision Number: <b>R003</b>	Page: <b>91 of 136</b>

Title:  
**REFERENCE LOW- AND INTERMEDIATE-LEVEL WASTE INVENTORY FOR THE DEEP GEOLOGIC REPOSITORY**

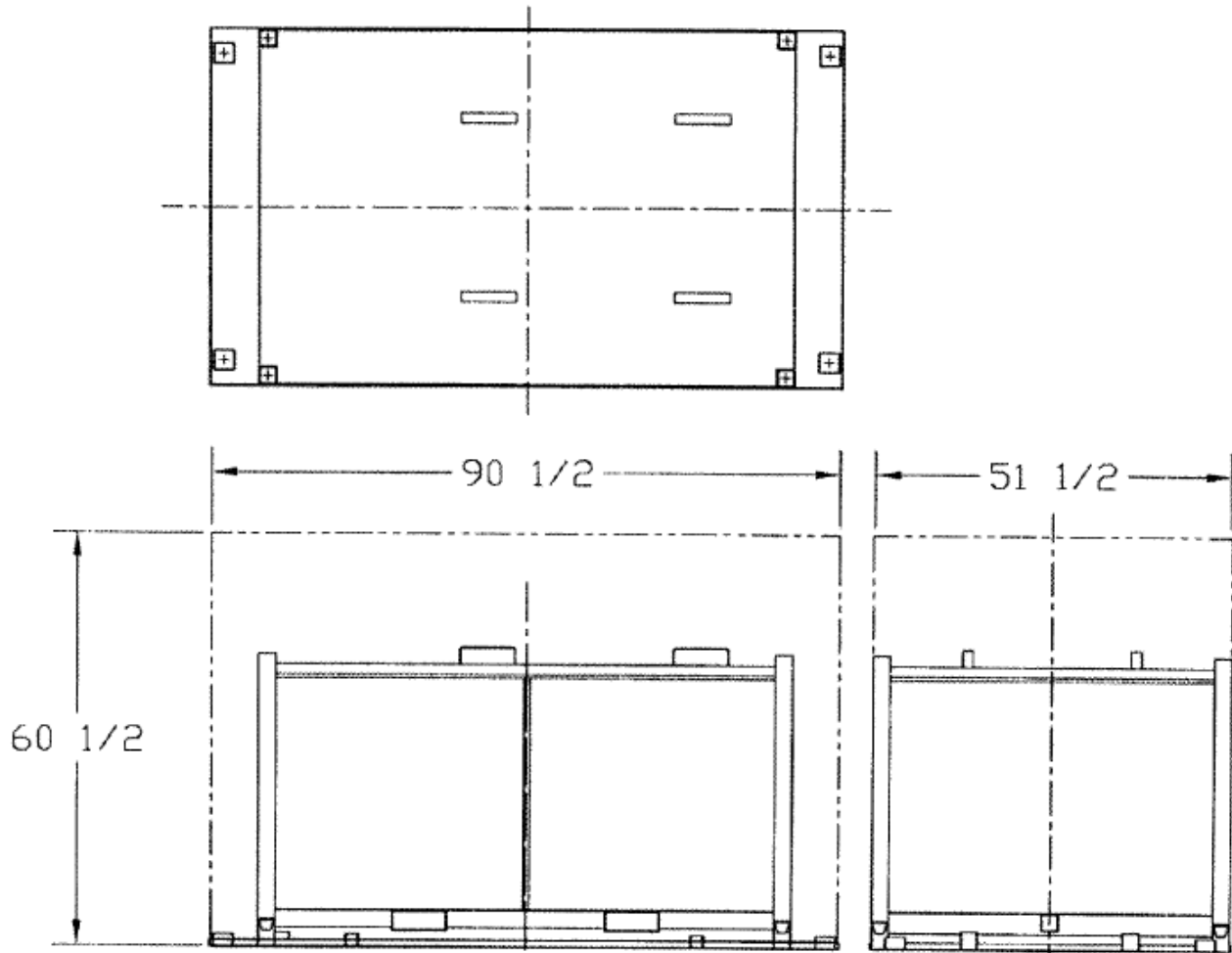

**Report**

OPG Proprietary		
Document Number:	00216-REP-03902-00003	Usage Classification: <b>INFORMATION</b>
Sheet Number:	N/A	Revision Number: R003
		Page: <b>92 of 136</b>

Title:

**REFERENCE LOW- AND INTERMEDIATE-LEVEL WASTE INVENTORY FOR THE DEEP GEOLOGIC REPOSITORY**

<b>Container Description</b>	<p>Container name: Low Level Resin Box (90")</p> <p>IWTS container code: RB90</p> <p>CATID: 216423</p> <p>Dimensions (m): 2.29 L x 1.22 W x 1.47 H</p> <p>External surface area (m<sup>2</sup>): 15.9</p> <p>Gross volume (m<sup>3</sup>): 4.2</p> <p>Net volume (m<sup>3</sup>): 3.4</p> <p>Material: Galvanized mild steel, 6.3 mm thick</p> <p>Empty mass (kg): 1,180</p> <p>Max gross mass (kg): 3,655</p> <p>Stackability: 4 high</p> <p>Handling: Forklift pockets</p>													
<b>Waste Properties</b>	<p>Typical contents: Dewatered low level ion exchange resin</p> <p>Typical composition: Resin beads containing interstitial water</p> <p>Potential hazardous constituents: May contain heavy metals and misc. organics</p> <p>Avg waste density (kg/m<sup>3</sup>): 750 (dry)</p> <p>Contact Dose rate (mSv/h): &lt;0.01: 80.4%; 0.01-0.05: 19.6%; 0.05-0.10: 0.0%</p> <p>Specific activity (Bq/m<sup>3</sup>): 2.2E+08</p>													
<b>Forecast Inventory*</b>	<table border="1"> <thead> <tr> <th></th> <th>To 2018</th> <th>To 2052</th> </tr> </thead> <tbody> <tr> <td>Number of containers**:</td> <td>80</td> <td>80</td> </tr> <tr> <td>Total gross volume (m<sup>3</sup>):</td> <td>328</td> <td>328</td> </tr> <tr> <td>Total net volume (m<sup>3</sup>):</td> <td>266</td> <td>266</td> </tr> </tbody> </table>		To 2018	To 2052	Number of containers**:	80	80	Total gross volume (m <sup>3</sup> ):	328	328	Total net volume (m <sup>3</sup> ):	266	266	
	To 2018	To 2052												
Number of containers**:	80	80												
Total gross volume (m <sup>3</sup> ):	328	328												
Total net volume (m <sup>3</sup> ):	266	266												
<b>Ref</b>	Dwg # 0125-DXH-79160-0003													

\* Entire forecast inventory to be packaged in LLW container overpacks (BINOPK).

\*\* Volumes include 77" long resin boxes.



Report

<b>OPG Proprietary</b>		
Document Number:	<b>00216-REP-03902-00003</b>	Usage Classification:
		<b>INFORMATION</b>
Sheet Number:	Revision Number:	Page:
<b>N/A</b>	<b>R003</b>	<b>93 of 136</b>

Title:

**REFERENCE LOW- AND INTERMEDIATE-LEVEL WASTE INVENTORY FOR THE DEEP GEOLOGIC REPOSITORY**

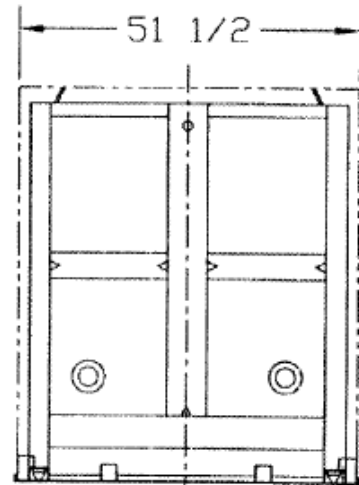
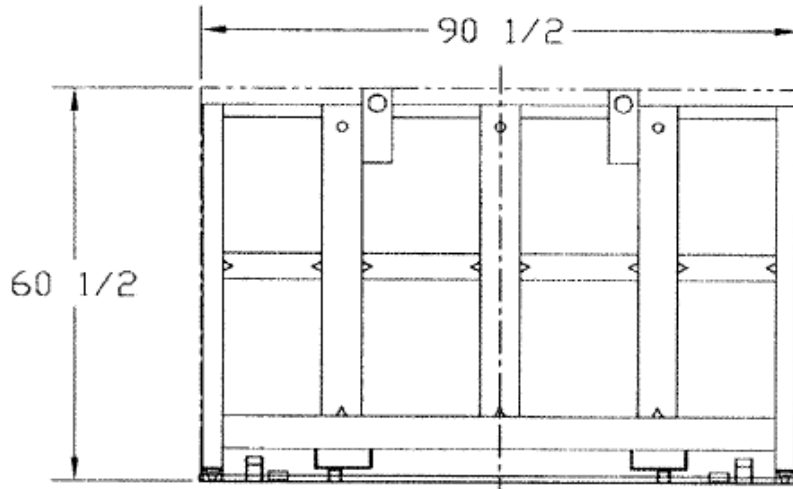
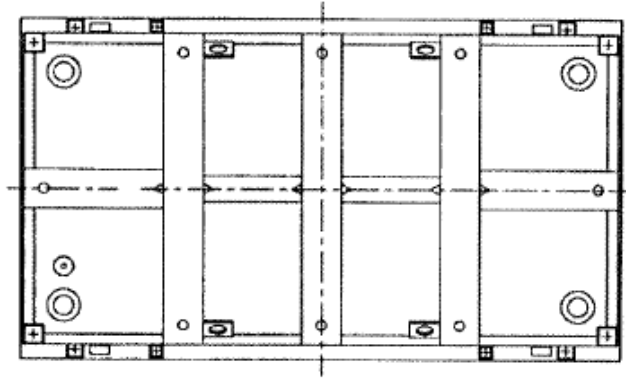

Report

OPG Proprietary		
Document Number:	00216-REP-03902-00003	Usage Classification: <b>INFORMATION</b>
Sheet Number:	Revision Number: R003	Page: 94 of 136

Title:

**REFERENCE LOW- AND INTERMEDIATE-LEVEL WASTE INVENTORY FOR THE DEEP GEOLOGIC REPOSITORY**

<b>Container Description</b>	<p>Container name: Low Level Resin Pallet Tank</p> <p>IWTS container code: RTK</p> <p>CATID: 488022 or 562649 for Darlington</p> <p>Dimensions (m): 1.24 L x 1.24 W x 1.68 H</p> <p>External surface area (m<sup>2</sup>): 11.4</p> <p>Gross volume (m<sup>3</sup>): 2.7</p> <p>Net volume (m<sup>3</sup>): 1.5</p> <p>Material: n/a</p> <p>Empty mass (kg): 320</p> <p>Max gross mass (kg): 2,000 (without overpack)</p> <p>Stackability: 3 high</p> <p>Handling: Forklift pockets</p>	
<b>Waste Properties</b>	<p>Typical contents: Dewatered low level ion exchange resin</p> <p>Typical composition: Resin beads containing interstitial water</p> <p>Potential hazardous constituents: May contain heavy metals and misc. organics</p> <p>Avg waste density (kg/m<sup>3</sup>): 750 (dry)</p> <p>Contact Dose rate (mSv/h): &lt;0.01: 80.4%; 0.01-0.05: 19.6%; 0.05-0.10: 0.0%</p> <p>Specific activity (Bq/m<sup>3</sup>): 2.2E+08</p>	
<b>Forecast Inventory</b>		
	<b>To 2018</b>	<b>To 2052</b>
	Number of containers: 745	2,085
	Total gross volume (m <sup>3</sup> ): 2,012	5,627
	Total net volume (m <sup>3</sup> ): 1,118	3,127
<b>Ref</b>	Dwg # PTC-330TDA-OPG488022 (Aco-Assman drawing)	

\* Expected to be covered in non-combustible carbon steel sheet or overpack for DGR.

Report

<b>OPG Proprietary</b>		
Document Number: <b>00216-REP-03902-00003</b>	Usage Classification: <b>INFORMATION</b>	
Sheet Number: <b>N/A</b>	Revision Number: <b>R003</b>	Page: <b>95 of 136</b>

Title:

**REFERENCE LOW- AND INTERMEDIATE-LEVEL WASTE INVENTORY FOR THE DEEP GEOLOGIC REPOSITORY**

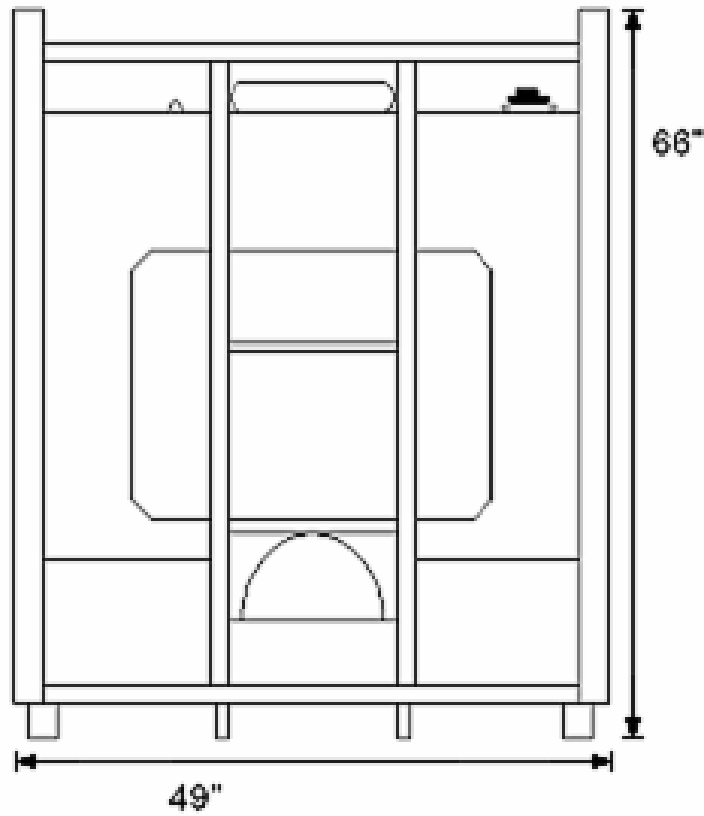
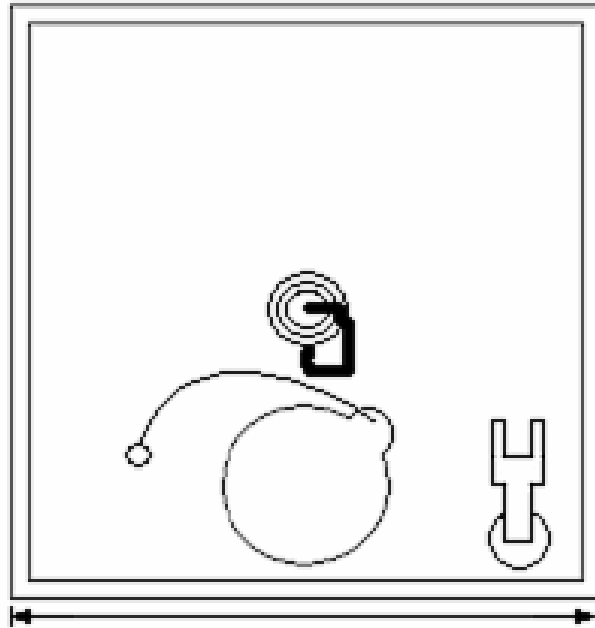

Report

<b>OPG Proprietary</b>		
Document Number:	<b>00216-REP-03902-00003</b>	Usage Classification:
		<b>INFORMATION</b>
Sheet Number:	Revision Number:	Page:
<b>N/A</b>	<b>R003</b>	<b>96 of 136</b>

Title:

**REFERENCE LOW- AND INTERMEDIATE-LEVEL WASTE INVENTORY FOR THE DEEP GEOLOGIC REPOSITORY**

<b>Container Description</b>	<p>Container name: ALW Sludge Box</p> <p>IWTS container code: NPBSB**</p> <p>CATID: 506066</p> <p>Dimensions (m): 1.96 L x 1.32 W x 1.03 H</p> <p>External surface area (m<sup>2</sup>): 11.9</p> <p>Gross volume (m<sup>3</sup>): 2.7</p> <p>Net volume (m<sup>3</sup>): 2.2</p> <p>Material: Hollow-steel-section and carbon steel sheet with seal welded joints (2.7 mm thick)</p> <p>Empty mass (kg): 380</p> <p>Max gross mass (kg): 1,820</p> <p>Stackability: 5 high</p> <p>Handling: Forklift pockets</p>													
<b>Waste Properties</b>	<p>Typical contents: Solidified ALW sludge</p> <p>Typical composition: Sludge from ALW system</p> <p>Potential hazardous constituents: n/a</p> <p>Avg waste density (kg/m<sup>3</sup>): n/a</p> <p>Contact Dose rate (mSv/h): &lt;0.1: 75%; 0.1-1: 25%; &gt;1: 0%;</p> <p>Specific activity (Bq/m<sup>3</sup>): 3.0E+09</p>													
<b>Forecast Inventory</b>		<table border="1"> <thead> <tr> <th></th> <th style="text-align: center;"><b>To 2018</b></th> <th style="text-align: center;"><b>To 2052</b></th> </tr> </thead> <tbody> <tr> <td>Number of containers:</td> <td style="text-align: center;">869</td> <td style="text-align: center;">1,709</td> </tr> <tr> <td>Total gross volume (m<sup>3</sup>)**:</td> <td style="text-align: center;">2,129</td> <td style="text-align: center;">4,395</td> </tr> <tr> <td>Total net volume (m<sup>3</sup>)**:</td> <td style="text-align: center;">1,722</td> <td style="text-align: center;">3,569</td> </tr> </tbody> </table>		<b>To 2018</b>	<b>To 2052</b>	Number of containers:	869	1,709	Total gross volume (m <sup>3</sup> )**:	2,129	4,395	Total net volume (m <sup>3</sup> )**:	1,722	3,569
	<b>To 2018</b>	<b>To 2052</b>												
Number of containers:	869	1,709												
Total gross volume (m <sup>3</sup> )**:	2,129	4,395												
Total net volume (m <sup>3</sup> )**:	1,722	3,569												
<b>Ref</b>	Dwg # 01098-DRAW-79165-10006													

\* Entire forecast inventory to be packaged in LLW container overpacks (BINOPK).

\*\* Representative sludge container. Volumes based on actual containers.

Report

<b>OPG Proprietary</b>		
Document Number:	<b>00216-REP-03902-00003</b>	Usage Classification:
		<b>INFORMATION</b>
Sheet Number:	Revision Number:	Page:
<b>N/A</b>	<b>R003</b>	<b>97 of 136</b>

Title:  
**REFERENCE LOW- AND INTERMEDIATE-LEVEL WASTE INVENTORY FOR THE DEEP GEOLOGIC REPOSITORY**

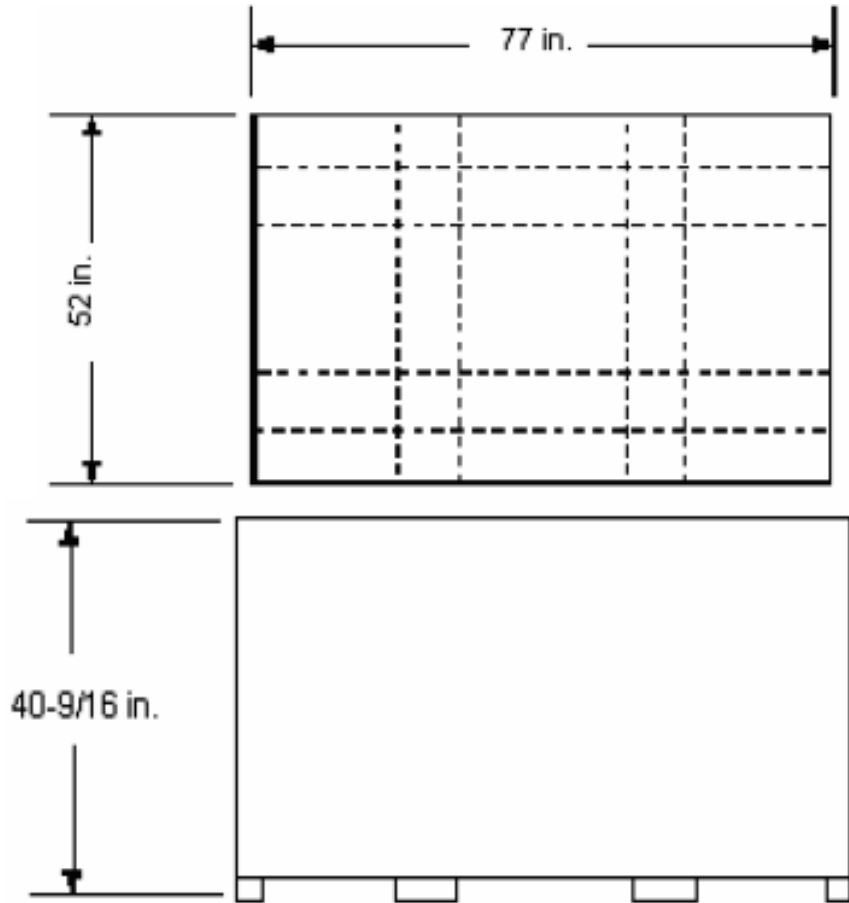

Report

OPG Proprietary		
Document Number:	00216-REP-03902-00003	Usage Classification: <b>INFORMATION</b>
Sheet Number:	Revision Number: R003	Page: 98 of 136

Title:

**REFERENCE LOW- AND INTERMEDIATE-LEVEL WASTE INVENTORY FOR THE DEEP GEOLOGIC REPOSITORY**

<b>Container Description</b>	<p>Container name: Shield Plug Container</p> <p>IWTS container code: SPC</p> <p>CATID: n/a</p> <p>Dimensions (m): 3.6 L x 1.9 W x 1.8 H*</p> <p>External surface area (m<sup>2</sup>): 28.1</p> <p>Gross volume (m<sup>3</sup>): 12.6</p> <p>Net volume (m<sup>3</sup>): 7.4</p> <p>Material: ASTM 30 carbon steel</p> <p>Empty mass (kg): 13,000</p> <p>Max gross mass (kg): 26,000</p> <p>Stackability: No stacking</p> <p>Handling: Crane</p>													
<b>Waste Properties</b>	<p>Typical contents: Shield plugs</p> <p>Typical composition: n/a</p> <p>Potential hazardous constituents: n/a</p> <p>Avg waste density (kg/m<sup>3</sup>): 1,760</p> <p>Contact Dose rate (mSv/h): &lt;0.1: 0%; 0.1-1: 5.6%; 1-2: 0%; 2-10: 33.3%; &gt;10: 61.1% (11 avg)</p> <p>Specific activity (Bq/m<sup>3</sup>): n/a</p>													
<b>Forecast Inventory</b>		<table border="1"> <thead> <tr> <th></th> <th>To 2018</th> <th>To 2052</th> </tr> </thead> <tbody> <tr> <td>Number of containers:</td> <td>22</td> <td>26</td> </tr> <tr> <td>Total gross volume (m<sup>3</sup>):</td> <td>277</td> <td>327</td> </tr> <tr> <td>Total net volume (m<sup>3</sup>):</td> <td>163</td> <td>192</td> </tr> </tbody> </table>		To 2018	To 2052	Number of containers:	22	26	Total gross volume (m <sup>3</sup> ):	277	327	Total net volume (m <sup>3</sup> ):	163	192
	To 2018	To 2052												
Number of containers:	22	26												
Total gross volume (m <sup>3</sup> ):	277	327												
Total net volume (m <sup>3</sup> ):	163	192												
<b>Ref</b>	Dwg # NK29-DRAW-35633-10043													

\* With protrusions.

**Report**

<b>OPG Proprietary</b>		
Document Number:	<b>00216-REP-03902-00003</b>	Usage Classification:
		<b>INFORMATION</b>
Sheet Number:	Revision Number:	Page:
<b>N/A</b>	<b>R003</b>	<b>99 of 136</b>

Title:

**REFERENCE LOW- AND INTERMEDIATE-LEVEL WASTE INVENTORY FOR THE DEEP GEOLOGIC REPOSITORY**

no drawing available

Report

OPG Proprietary		
Document Number:	Usage Classification:	
<b>00216-REP-03902-00003</b>	<b>INFORMATION</b>	
Sheet Number:	Revision Number:	Page:
<b>N/A</b>	<b>R003</b>	<b>100 of 136</b>

Title:

**REFERENCE LOW- AND INTERMEDIATE-LEVEL WASTE INVENTORY FOR THE DEEP GEOLOGIC REPOSITORY**

<b>Container Description</b>	<p>Container name: LLW Container Overpack</p> <p>IWTS container code: BINOPK</p> <p>CATID: 624979</p> <p>Dimensions (m): 2.54 L x 1.78 W x 1.88 H</p> <p>External surface area (m<sup>2</sup>): 25.1</p> <p>Gross volume (m<sup>3</sup>): 8.5</p> <p>Net volume (m<sup>3</sup>): 6.56</p> <p>Material: Sheet metal reinforced with extruded or formed shapes (3.4 mm thick)</p> <p>Empty mass (kg): 1,591</p> <p>Max gross mass (kg): 5,400*</p> <p>Stackability: 3 high</p> <p>Handling: Forklift pockets</p>													
<b>Waste Properties</b>	<p>Typical contents: Low level waste containers damaged during loading or handling, or that have corroded over extended storage</p> <p>Typical composition: n/a</p> <p>Potential hazardous constituents: n/a</p> <p>Avg waste density (kg/m<sup>3</sup>): n/a</p> <p>Contact Dose rate (mSv/h): n/a</p> <p>Specific activity (Bq/m<sup>3</sup>): n/a</p>													
<b>Forecast Inventory</b>		<table border="1"> <thead> <tr> <th></th> <th>To 2018</th> <th>To 2052</th> </tr> </thead> <tbody> <tr> <td>Number of containers:</td> <td>1,873</td> <td>3,212</td> </tr> <tr> <td>Total gross volume (m<sup>3</sup>):</td> <td>15,916</td> <td>27,303</td> </tr> <tr> <td>Total net volume (m<sup>3</sup>):</td> <td>**</td> <td>**</td> </tr> </tbody> </table>		To 2018	To 2052	Number of containers:	1,873	3,212	Total gross volume (m <sup>3</sup> ):	15,916	27,303	Total net volume (m <sup>3</sup> ):	**	**
	To 2018	To 2052												
Number of containers:	1,873	3,212												
Total gross volume (m <sup>3</sup> ):	15,916	27,303												
Total net volume (m <sup>3</sup> ):	**	**												
<b>Ref</b>	Dwg # 01098-DRAW-79135-10001													

\* Max capacity to be finalized.

\*\* Depends on net volume of LLW container.



<b>OPG Proprietary</b>		
Document Number: <b>00216-REP-03902-00003</b>		Usage Classification: <b>INFORMATION</b>
Sheet Number: <b>N/A</b>	Revision Number: <b>R003</b>	Page: <b>101 of 136</b>

Title:  
**REFERENCE LOW- AND INTERMEDIATE-LEVEL WASTE INVENTORY FOR THE DEEP GEOLOGIC REPOSITORY**

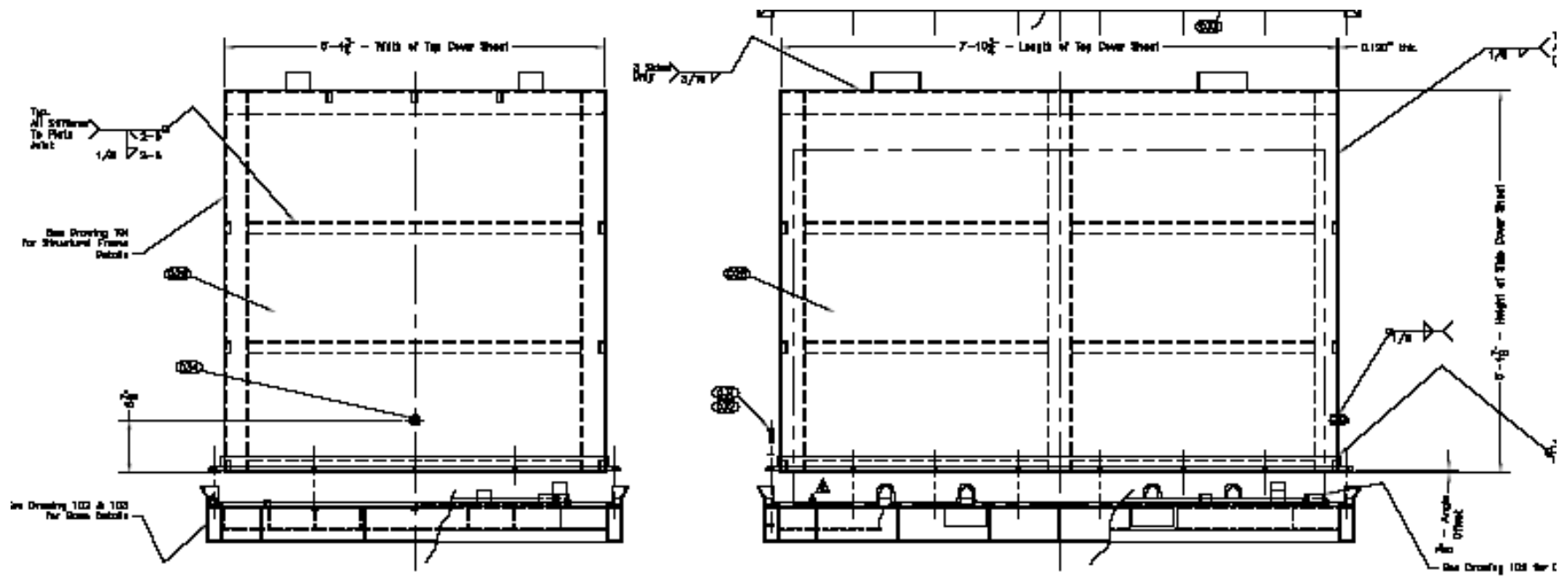

Report

OPG Proprietary		
Document Number:	00216-REP-03902-00003	Usage Classification: <b>INFORMATION</b>
Sheet Number:	Revision Number: R003	Page: 102 of 136

Title:

**REFERENCE LOW- AND INTERMEDIATE-LEVEL WASTE INVENTORY FOR THE DEEP GEOLOGIC REPOSITORY**

Container Description	Container name: Heat Exchanger IWTS container code: HX CATID: n/a Dimensions (m): n/a External surface area (m <sup>2</sup> ): n/a Gross volume (m <sup>3</sup> ): 10-51 Material: Carbon steel shell, high alloy steel tubes Empty mass (kg): 10,000-30,000 Max gross mass (kg): n/a Stackability: n/a Handling: Crane		
	Typical contents: Contaminated HX tube bundles Typical composition: Carbon steel shell, alloy tubes Potential hazardous constituents: n/a Avg waste density (kg/m <sup>3</sup> ): n/a Contact Dose rate (mSv/h): <0.1: 56.1%; 0.1-1: 36.6%; 1-2: 7.3%; >2 0% Specific activity (Bq/m <sup>3</sup> ): 3.0E+10		
Forecast Inventory		<b>To 2018</b>	<b>To 2052</b>
	Number of containers: Total gross volume (m <sup>3</sup> ):	98 2,775	98 2,775
Ref	Dwg # n/a		

Report

<b>OPG Proprietary</b>		
Document Number:	00216-REP-03902-00003	Usage Classification: <b>INFORMATION</b>
Sheet Number:	N/A	Revision Number: <b>R003</b>
		Page: <b>103 of 136</b>

Title:

**REFERENCE LOW- AND INTERMEDIATE-LEVEL WASTE INVENTORY FOR THE DEEP GEOLOGIC REPOSITORY**

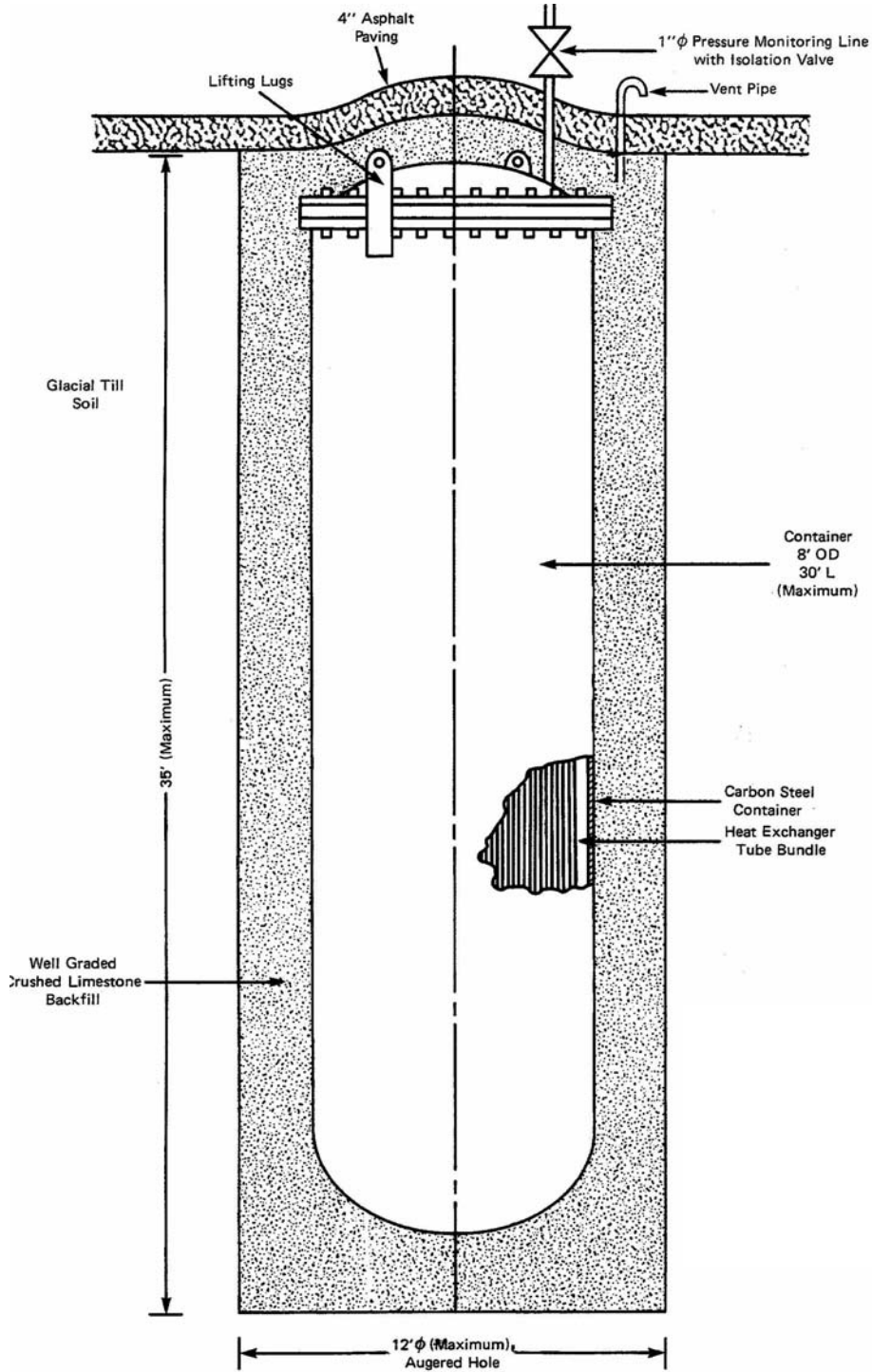

Note: This sketch is not to scale.

Report

OPG Proprietary		
Document Number:	00216-REP-03902-00003	Usage Classification: <b>INFORMATION</b>
Sheet Number:	Revision Number: R003	Page: 104 of 136

Title:

**REFERENCE LOW- AND INTERMEDIATE-LEVEL WASTE INVENTORY FOR THE DEEP GEOLOGIC REPOSITORY**

Container Description	Container name: Encapsulated Tile Hole IWTS container code: ETH CATID: n/a Dimensions (m): 1.5 OD x 4.6 OL External surface area (m <sup>2</sup> ): 20.5 Gross volume (m <sup>3</sup> ): 7.6 Net volume (m <sup>3</sup> ): 7.6 Material: Tile hole removed and encapsulated in cement in steel pipe, 9.5 mm thick Empty mass (kg): n/a Max gross mass (kg): 25,000 Stackability: 1 high Handling: Forklift pockets		
	Typical contents: Small filters and disposable ion-exchange columns Typical composition: n/a Potential hazardous constituents: n/a Avg waste density (kg/m <sup>3</sup> ): n/a Contact Dose rate (mSv/h): <0.01: 0.0%; 0.01-0.05: 56.5%; 0.05-0.10: 26.1%; 0.10-0.20: 13.0%; 0.20-0.50: 4.4%; 0.50-1: 0.0%; 1-2: 0.0%; 2-10: 0.0%; >10: 0.0% Specific activity (Bq/m <sup>3</sup> ): 3.0E+10		
Forecast Inventory		<b>To 2018</b>	<b>To 2052</b>
	Number of containers:	23	23
	Total gross volume (m <sup>3</sup> ):	177	504
	Total net volume (m <sup>3</sup> ):	177	504
Ref	Dwg # 0125-DRAW-79100-10002 sheet 0001		

**Report**

<b>OPG Proprietary</b>		
Document Number: <b>00216-REP-03902-00003</b>		Usage Classification: <b>INFORMATION</b>
Sheet Number: <b>N/A</b>	Revision Number: <b>R003</b>	Page: <b>105 of 136</b>

Title:

**REFERENCE LOW- AND INTERMEDIATE-LEVEL WASTE INVENTORY FOR THE DEEP GEOLOGIC REPOSITORY**

no drawing available

Report

OPG Proprietary		
Document Number:	00216-REP-03902-00003	Usage Classification: <b>INFORMATION</b>
Sheet Number:	N/A	Revision Number: R003
		Page: <b>106 of 136</b>

Title:

**REFERENCE LOW- AND INTERMEDIATE-LEVEL WASTE INVENTORY FOR THE DEEP GEOLOGIC REPOSITORY**

<b>Container Description</b>	<p>Container name: Resin Liner</p> <p>IWTS container code: RL*</p> <p>CATID: 216823 (old design)</p> <p>Dimensions (m): 1.63 OD x 1.8 OL</p> <p>External surface area (m<sup>2</sup>): 13.4</p> <p>Gross volume (m<sup>3</sup>): 3 (nominal)</p> <p>Net volume (m<sup>3</sup>): 3</p> <p>Material: Coal tar epoxy coated, mild steel, 6.3 mm thick</p> <p>Empty mass (kg): 795</p> <p>Max gross mass (kg): 4,545</p> <p>Stackability: Up to 6 high**</p> <p>Handling: Crane</p>	
<b>Waste Properties</b>	<p>Typical contents: Dewatered intermediate level ion exchange resin</p> <p>Typical composition: Ion exchange resin beads</p> <p>Potential hazardous constituents: May contain heavy metals and misc. organics</p> <p>Avg waste density (kg/m<sup>3</sup>): 850 (dry)</p> <p>Contact Dose rate (mSv/h): &lt;0.01: 7.0%; 0.01-0.05: 0.8%; 0.05-0.10: 3.5%; 0.10-0.20: 2.6%; 0.20-0.50: 6.1%; 0.50-1: 4.5%; 1-2: 3.6%; 2-10: 21.4%; &gt;10: 50.5%</p> <p>Specific activity (Bq/m<sup>3</sup>): 3.6E+12 (e.g., Moderator resin)</p>	
<b>Forecast Inventory</b>		
<b>Ref</b>	Dwg # 0125-D0H-79162-0001 R1	

**Note:** RLS (including RLOPKs) will be placed in DGR as-is or in a mix RSHLD1, RSHLD2 and RSHLD3 packages.

\* Representative container design. RLSS is same dimensions but made from stainless steel.

\*\* Older RL in quadricell are designed for 2 high stacking; RL in IC-12s for 4-high stacking.

Report

<b>OPG Proprietary</b>		
Document Number:	00216-REP-03902-00003	Usage Classification: <b>INFORMATION</b>
Sheet Number: N/A	Revision Number: R003	Page: 107 of 136

Title:  
**REFERENCE LOW- AND INTERMEDIATE-LEVEL WASTE INVENTORY FOR THE DEEP GEOLOGIC REPOSITORY**

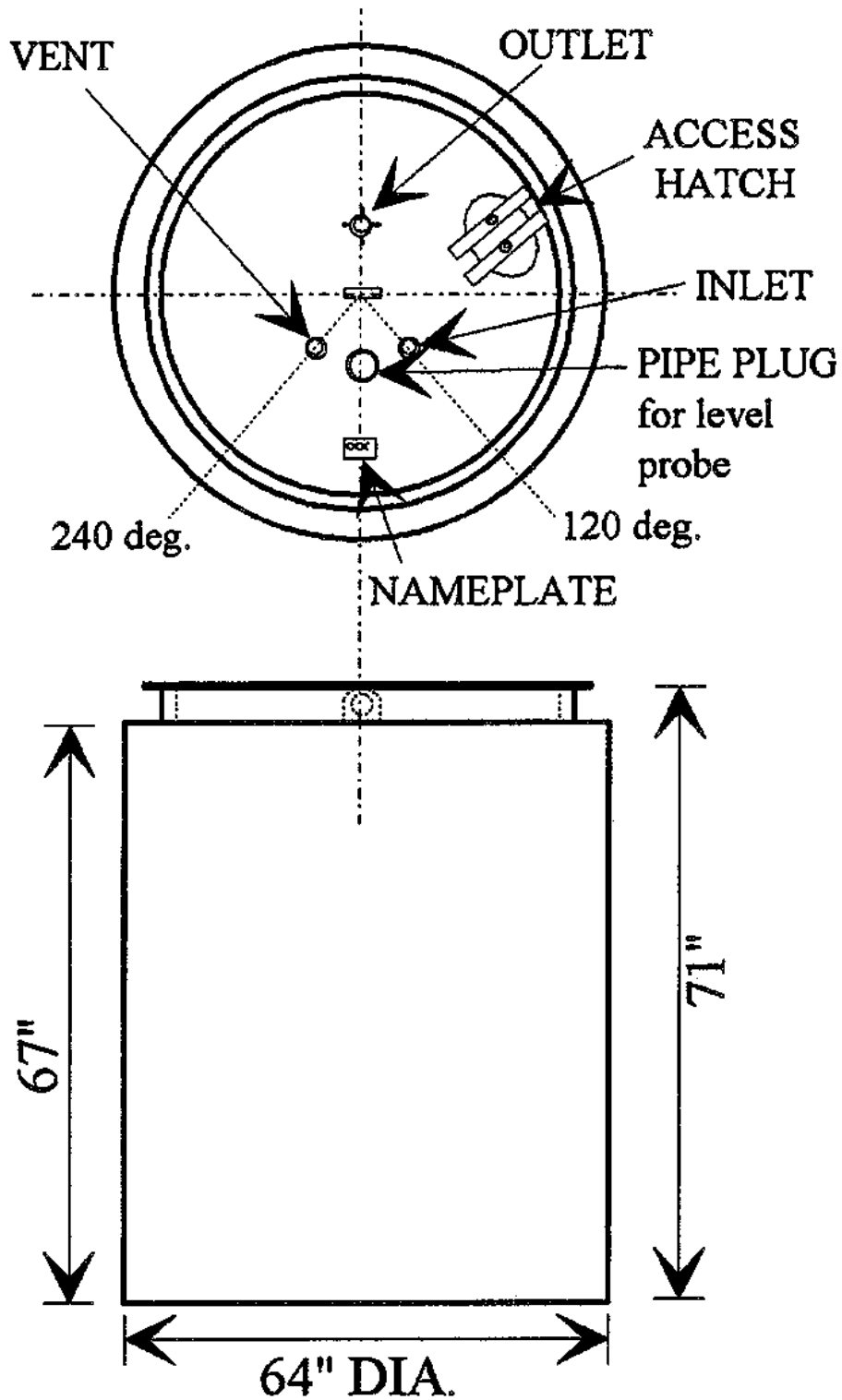

Report

OPG Proprietary		
Document Number:	00216-REP-03902-00003	Usage Classification: <b>INFORMATION</b>
Sheet Number:	N/A	Revision Number: R003
		Page: 108 of 136

Title:

**REFERENCE LOW- AND INTERMEDIATE-LEVEL WASTE INVENTORY FOR THE DEEP GEOLOGIC REPOSITORY**

<b>Container Description</b>	<p>Container name: Resin Liner Overpack                  IWTS container code: RLOPK                  CATID: n/a                  Dimensions (m): 1.68 OD x 1.91 OL                  External surface area (m<sup>2</sup>): 14.2                  Gross volume (m<sup>3</sup>): 4.1                  Net volume (m<sup>3</sup>): 3                  Material: Stainless steel                  Empty mass (kg): 1,450                  Max gross mass (kg): 6,000                  Stackability: 6 high                  Handling: Crane</p>		
	<p>Typical contents: Dewatered intermediate level ion exchange resin                  Typical composition: Ion exchange resin beads                  Potential hazardous constituents: May contain heavy metals and misc. organics                  Avg waste density (kg/m<sup>3</sup>): 850 (dry)                  Contact Dose rate (mSv/h): &lt;0.01: 7.0%; 0.01-0.05: 0.8%; 0.05-0.10: 3.5%; 0.10-0.20: 2.6%; 0.20-0.50: 6.1%; 0.50-1: 4.5%; 1-2: 3.6%; 2-10: 21.4%; &gt;10: 50.5%                  Specific activity (Bq/m<sup>3</sup>): 3.6E+12</p>		
<b>Forecast Inventory</b>		<b>To 2018</b>	<b>To 2052</b>
	Number of containers:	400	400
	Total gross volume (m <sup>3</sup> ):	1,640	1,640
	Total net volume (m <sup>3</sup> ):	1,200	1,200
<b>Ref</b>	Dwg # 01098-DRAW-79164-00007		



Report

<b>OPG Proprietary</b>		
Document Number:	Usage Classification:	
<b>00216-REP-03902-00003</b>	<b>INFORMATION</b>	
Sheet Number:	Revision Number:	Page:
<b>N/A</b>	<b>R003</b>	<b>109 of 136</b>

Title:

**REFERENCE LOW- AND INTERMEDIATE-LEVEL WASTE INVENTORY FOR THE DEEP GEOLOGIC REPOSITORY**

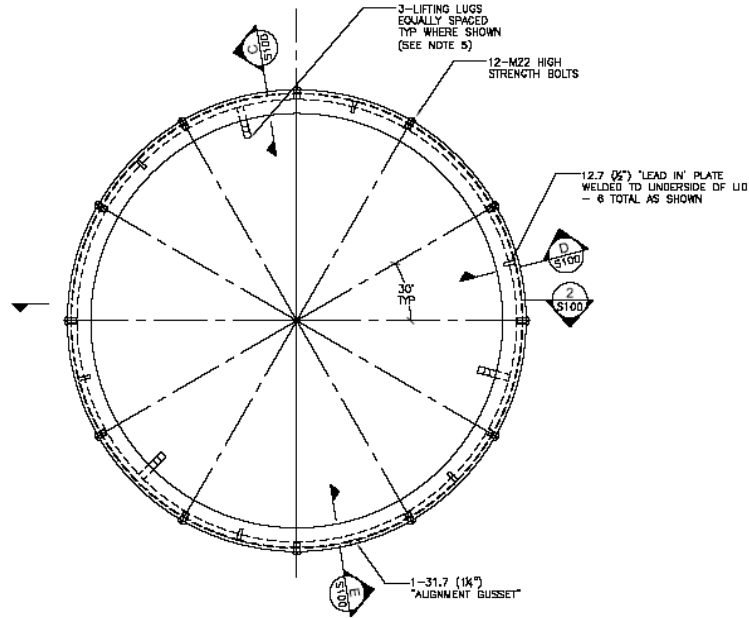

PLAN VIEW ①  
1 : 10 S100

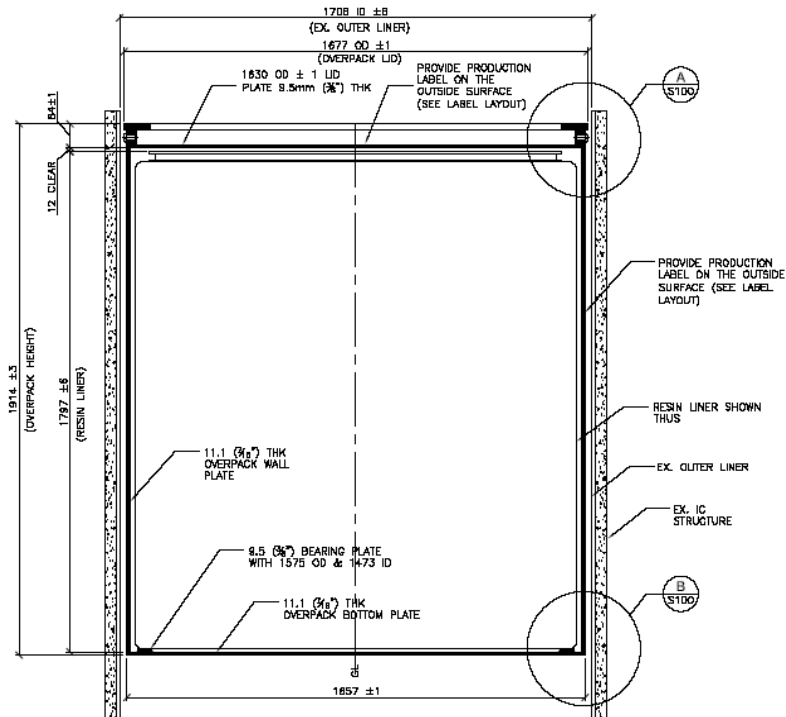

SECTION ②  
1 : 10 S100

Report

OPG Proprietary		
Document Number:	00216-REP-03902-00003	Usage Classification: <b>INFORMATION</b>
Sheet Number:	Revision Number: R003	Page: 110 of 136

Title:

**REFERENCE LOW- AND INTERMEDIATE-LEVEL WASTE INVENTORY FOR THE DEEP GEOLOGIC REPOSITORY**

<b>Container Description</b>	<p>Container name: Resin Liner Shield 1</p> <p>IWTS container code: RLSHLD1</p> <p>CATID: n/a</p> <p>Dimensions (m): 2.2 OD x 4.25 OL</p> <p>External surface area (m<sup>2</sup>): 37</p> <p>Gross volume (m<sup>3</sup>): 16.2</p> <p>Net volume (m<sup>3</sup>): 6 <span style="float: right;">Picture n/a</span></p> <p>Material: 250 mm thick concrete</p> <p>Empty mass (kg): 17,760</p> <p>Max gross mass (kg): 26,850</p> <p>Stackability: 1 high</p> <p>Handling: Forklift</p>												
<b>Waste Properties</b>	<p>Typical contents: 2 resin liners containing dewatered intermediate level ion exchange resin</p> <p>Typical composition: Ion exchange resin beads</p> <p>Potential hazardous constituents: May contain heavy metals and misc. organics</p> <p>Avg waste density (kg/m<sup>3</sup>): 850 (dry)</p> <p>Contact Dose rate (mSv/h): &lt; 2</p> <p>Specific activity (Bq/m<sup>3</sup>): 3.6E+12</p>												
<b>Forecast Inventory</b>	<table border="1"> <thead> <tr> <th></th> <th>To 2018</th> <th>To 2052</th> </tr> </thead> <tbody> <tr> <td>Number of containers:</td> <td>398</td> <td>646</td> </tr> <tr> <td>Total gross volume (m<sup>3</sup>):</td> <td>6,440</td> <td>10,467</td> </tr> <tr> <td>Total net volume (m<sup>3</sup>):</td> <td>2,385</td> <td>3,877</td> </tr> </tbody> </table>		To 2018	To 2052	Number of containers:	398	646	Total gross volume (m <sup>3</sup> ):	6,440	10,467	Total net volume (m <sup>3</sup> ):	2,385	3,877
	To 2018	To 2052											
Number of containers:	398	646											
Total gross volume (m <sup>3</sup> ):	6,440	10,467											
Total net volume (m <sup>3</sup> ):	2,385	3,877											
<b>Ref</b>	Dwg # n/a												

Note: Design under review.

Report

<b>OPG Proprietary</b>		
Document Number:	<b>00216-REP-03902-00003</b>	Usage Classification:
		<b>INFORMATION</b>
Sheet Number:	Revision Number:	Page:
<b>N/A</b>	<b>R003</b>	<b>111 of 136</b>

Title:  
**REFERENCE LOW- AND INTERMEDIATE-LEVEL WASTE INVENTORY FOR THE DEEP GEOLOGIC REPOSITORY**

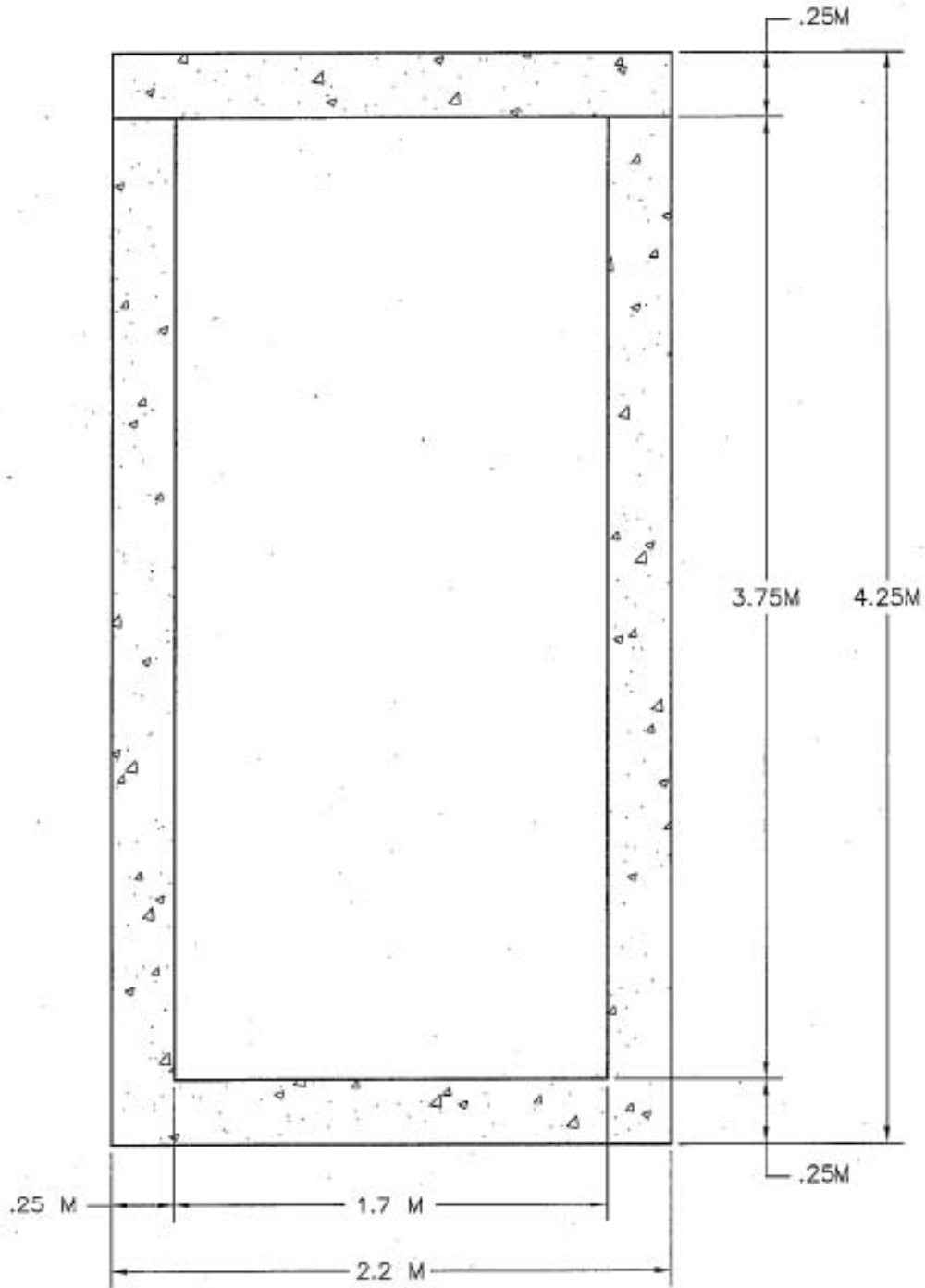

EMPTY WEIGHT = 17,760 Kg.

Report

OPG Proprietary		
Document Number:	00216-REP-03902-00003	Usage Classification: <b>INFORMATION</b>
Sheet Number: <b>N/A</b>	Revision Number: <b>R003</b>	Page: <b>112 of 136</b>

Title:

**REFERENCE LOW- AND INTERMEDIATE-LEVEL WASTE INVENTORY FOR THE DEEP GEOLOGIC REPOSITORY**

<b>Container Description</b>	<p>Container name: Resin Liner Shield 2</p> <p>IWTS container code: RLSHLD2</p> <p>CATID: n/a</p> <p>Dimensions (m): 2.4 OD x 4.45 OL</p> <p>External surface area (m<sup>2</sup>): 42.6</p> <p>Gross volume (m<sup>3</sup>): 20.1</p> <p>Net volume (m<sup>3</sup>): 6 <span style="float: right;">Picture n/a</span></p> <p>Material: 350 mm thick concrete</p> <p>Empty mass (kg): 27,060</p> <p>Max gross mass (kg): 36,150</p> <p>Stackability: 1 high</p> <p>Handling: Forklift</p>												
<b>Waste Properties</b>	<p>Typical contents: 2 resin liners containing dewatered intermediate level ion exchange resin</p> <p>Typical composition: Ion exchange resin beads</p> <p>Potential hazardous constituents: May contain heavy metals and misc. organics</p> <p>Avg waste density (kg/m<sup>3</sup>): 850</p> <p>Contact Dose rate (mSv/h): &lt; 2</p> <p>Specific activity (Bq/m<sup>3</sup>): 3.6E+12</p>												
<b>Forecast Inventory</b>	<table border="1" style="width: 100%; border-collapse: collapse;"> <thead> <tr> <th></th> <th style="text-align: center;"><b>To 2018</b></th> <th style="text-align: center;"><b>To 2052</b></th> </tr> </thead> <tbody> <tr> <td>Number of containers:</td> <td style="text-align: center;">101</td> <td style="text-align: center;">164</td> </tr> <tr> <td>Total gross volume (m<sup>3</sup>):</td> <td style="text-align: center;">2,020</td> <td style="text-align: center;">3,295</td> </tr> <tr> <td>Total net volume (m<sup>3</sup>):</td> <td style="text-align: center;">603</td> <td style="text-align: center;">984</td> </tr> </tbody> </table>		<b>To 2018</b>	<b>To 2052</b>	Number of containers:	101	164	Total gross volume (m <sup>3</sup> ):	2,020	3,295	Total net volume (m <sup>3</sup> ):	603	984
	<b>To 2018</b>	<b>To 2052</b>											
Number of containers:	101	164											
Total gross volume (m <sup>3</sup> ):	2,020	3,295											
Total net volume (m <sup>3</sup> ):	603	984											
<b>Ref</b>	Dwg # n/a												

Note: Design under review.

**Report**

<b>OPG Proprietary</b>		
Document Number: <b>00216-REP-03902-00003</b>		Usage Classification: <b>INFORMATION</b>
Sheet Number: <b>N/A</b>	Revision Number: <b>R003</b>	Page: <b>113 of 136</b>

Title:

**REFERENCE LOW- AND INTERMEDIATE-LEVEL WASTE INVENTORY FOR THE DEEP GEOLOGIC REPOSITORY**

no drawing available

Report

OPG Proprietary		
Document Number:	00216-REP-03902-00003	Usage Classification: <b>INFORMATION</b>
Sheet Number:	Revision Number: R003	Page: 114 of 136

Title:

**REFERENCE LOW- AND INTERMEDIATE-LEVEL WASTE INVENTORY FOR THE DEEP GEOLOGIC REPOSITORY**

<b>Container Description</b>	<p>Container name: Resin Liner Shield 3</p> <p>IWTS container code: RLSHLD3</p> <p>CATID: n/a</p> <p>Dimensions (m): 2.53 OD x 2.74 OL</p> <p>External surface area (m<sup>2</sup>): 31.8</p> <p>Gross volume (m<sup>3</sup>): 13.8</p> <p>Net volume (m<sup>3</sup>): 3 <span style="float: right;">Picture n/a</span></p> <p>Material: 350 mm thick concrete with 40 mm thick steel insert</p> <p>Empty mass (kg): 24,420</p> <p>Max gross mass (kg): 28,965</p> <p>Stackability: 1 high</p> <p>Handling: Forklift</p>												
<b>Waste Properties</b>	<p>Typical contents: 1 resin liner containing dewatered intermediate level ion exchange resin</p> <p>Typical composition: Ion exchange resin beads</p> <p>Potential hazardous constituents: May contain heavy metals and misc. organics</p> <p>Avg waste density (kg/m<sup>3</sup>): 850</p> <p>Contact Dose rate (mSv/h): &lt; 2</p> <p>Specific activity (Bq/m<sup>3</sup>): 3.6E+12</p>												
<b>Forecast Inventory</b>	<table border="1"> <thead> <tr> <th></th> <th>To 2018</th> <th>To 2052</th> </tr> </thead> <tbody> <tr> <td>Number of containers:</td> <td>86</td> <td>140</td> </tr> <tr> <td>Total gross volume (m<sup>3</sup>):</td> <td>1,180</td> <td>1,925</td> </tr> <tr> <td>Total net volume (m<sup>3</sup>):</td> <td>257</td> <td>420</td> </tr> </tbody> </table>		To 2018	To 2052	Number of containers:	86	140	Total gross volume (m <sup>3</sup> ):	1,180	1,925	Total net volume (m <sup>3</sup> ):	257	420
	To 2018	To 2052											
Number of containers:	86	140											
Total gross volume (m <sup>3</sup> ):	1,180	1,925											
Total net volume (m <sup>3</sup> ):	257	420											
<b>Ref</b>	Dwg # n/a												

Note: Design under review.

Report

<b>OPG Proprietary</b>		
Document Number: <b>00216-REP-03902-00003</b>	Usage Classification: <b>INFORMATION</b>	
Sheet Number: <b>N/A</b>	Revision Number: <b>R003</b>	Page: <b>115 of 136</b>

Title:

**REFERENCE LOW- AND INTERMEDIATE-LEVEL WASTE INVENTORY FOR THE DEEP GEOLOGIC REPOSITORY**

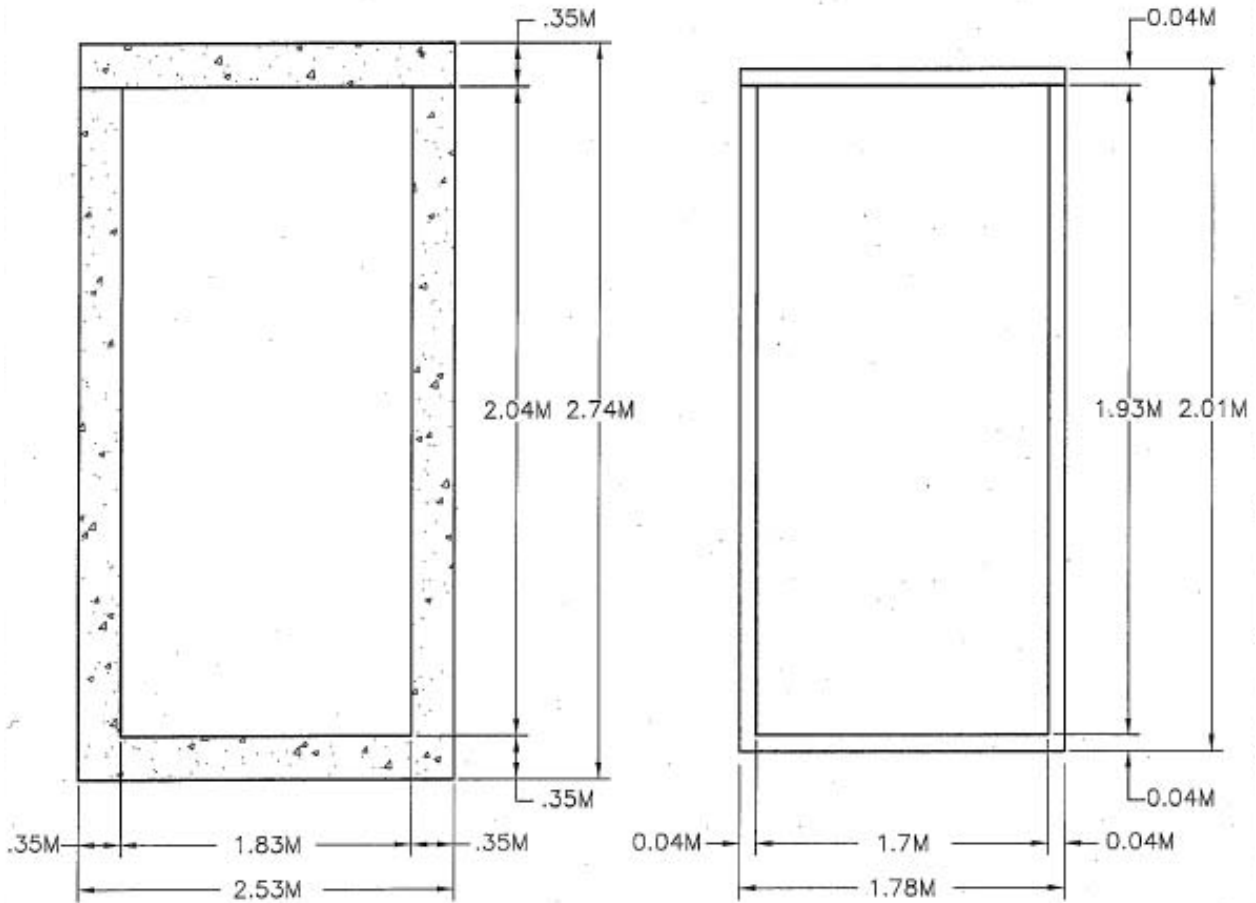

WEIGHT-CONCRETE SHIELD = 19,535 Kg.  
WEIGHT-STEEL SHIELD = 4,005 Kg.  
EMPTY WEIGHT = 24,420 Kg.

**Report**

<b>OPG Proprietary</b>		
Document Number:	<b>00216-REP-03902-00003</b>	Usage Classification: <b>INFORMATION</b>
Sheet Number: <b>N/A</b>	Revision Number: <b>R003</b>	Page: <b>116 of 136</b>

Title:

**REFERENCE LOW- AND INTERMEDIATE-LEVEL WASTE INVENTORY FOR THE DEEP GEOLOGIC REPOSITORY**

<b>Container Description</b>	<p>Container name: Alternative Tile Hole Equivalent Liner (ATHEL) Shield</p> <p>IWTS container code: ATHELSHLD</p> <p>CATID: n/a</p> <p>Dimensions (m): 2.53 OD x 2.74 OL</p> <p>External surface area (m<sup>2</sup>): 31.8</p> <p>Gross volume (m<sup>3</sup>): 13.8</p> <p>Net volume (m<sup>3</sup>): 3</p> <p>Material: Stainless steel liner (6.3 mm thick) 350 mm thick concrete overpack*</p> <p>Empty mass (kg): 20,900</p> <p>Max gross mass (kg): 23,500</p> <p>Stackability: Up to 2 high*</p> <p>Handling: Forklift</p>	Picture n/a
<b>Waste Properties</b>	<p>Typical contents: Retrieved contents from IC-2 and IC-18 T-H-Es (e.g. Filters, IX columns, bagged wastes, and core components)</p> <p>Typical composition: n/a</p> <p>Potential hazardous constituents: n/a</p> <p>Avg waste density (kg/m<sup>3</sup>): n/a</p> <p>Contact Dose rate (mSv/h): &lt; 2</p> <p>Specific activity (Bq/m<sup>3</sup>): n/a</p>	
<b>Forecast Inventory</b>	<b>To 2018</b>	<b>To 2052</b>
	Number of containers: 300	300
	Total gross volume (m <sup>3</sup> ): 4,140	4,140
	Total net volume (m <sup>3</sup> ): 900	900
<b>Ref</b>	Dwg # n/a	

\*Note: Conceptual design. Final design may be based on a small number of concrete overpack types..



**Report**

<b>OPG Proprietary</b>		
Document Number: <b>00216-REP-03902-00003</b>		Usage Classification: <b>INFORMATION</b>
Sheet Number: <b>N/A</b>	Revision Number: <b>R003</b>	Page: <b>117 of 136</b>

Title:

**REFERENCE LOW- AND INTERMEDIATE-LEVEL WASTE INVENTORY FOR THE DEEP GEOLOGIC REPOSITORY**

no drawing available

Report

OPG Proprietary		
Document Number:	00216-REP-03902-00003	Usage Classification: <b>INFORMATION</b>
Sheet Number: <b>N/A</b>	Revision Number: <b>R003</b>	Page: <b>118 of 136</b>

Title:

**REFERENCE LOW- AND INTERMEDIATE-LEVEL WASTE INVENTORY FOR THE DEEP GEOLOGIC REPOSITORY**

<b>Container Description</b>	<p>Container name: Tile Hole Liner          IWTS container code: THLSTG3          CATID: n/a          Dimensions (m): 0.61 OD x 3.4 OL          External surface area (m<sup>2</sup>): 6.8          Gross volume (m<sup>3</sup>): 1.0          Net volume (m<sup>3</sup>): 0.9          Material: Retrievable steel liner with welded end plate          Empty mass (kg): 450          Max gross mass (kg): 2,000          Stackability: n/a          Handling: Lifting bracket</p> 												
<b>Waste Properties</b>	<p>Typical contents: Filter vessels, IX columns, core component liners, filter elements and bagged waste          Typical composition: n/a          Potential hazardous constituents: n/a          Avg waste density (kg/m<sup>3</sup>): n/a          Contact Dose rate (mSv/h): &lt;0.01: 2.9%; 0.01-0.05: 0.7%; 0.05-0.10: 0.0%; 0.10-0.20: 0.0%; 0.20-0.50: 0.0%; 0.50-1: 4.4%; 1-2: 4.1%; 2-10: 57.2%; &gt;10: 30.7%          Specific activity (Bq/m<sup>3</sup>): n/a</p>												
<b>Forecast Inventory</b>	<table border="1"> <thead> <tr> <th></th> <th>To 2018</th> <th>To 2052</th> </tr> </thead> <tbody> <tr> <td>Number of containers:</td> <td>201</td> <td>201</td> </tr> <tr> <td>Total gross volume (m<sup>3</sup>):</td> <td>201</td> <td>201</td> </tr> <tr> <td>Total net volume (m<sup>3</sup>):</td> <td>181</td> <td>181</td> </tr> </tbody> </table>		To 2018	To 2052	Number of containers:	201	201	Total gross volume (m <sup>3</sup> ):	201	201	Total net volume (m <sup>3</sup> ):	181	181
	To 2018	To 2052											
Number of containers:	201	201											
Total gross volume (m <sup>3</sup> ):	201	201											
Total net volume (m <sup>3</sup> ):	181	181											
<b>Ref</b>	Dwg # 0125-DAH-27942-2005 R01												

Report

<b>OPG Proprietary</b>		
Document Number:	00216-REP-03902-00003	Usage Classification: <b>INFORMATION</b>
Sheet Number:	N/A	Revision Number: R003
		Page: 119 of 136

Title:  
**REFERENCE LOW- AND INTERMEDIATE-LEVEL WASTE INVENTORY FOR THE DEEP GEOLOGIC REPOSITORY**

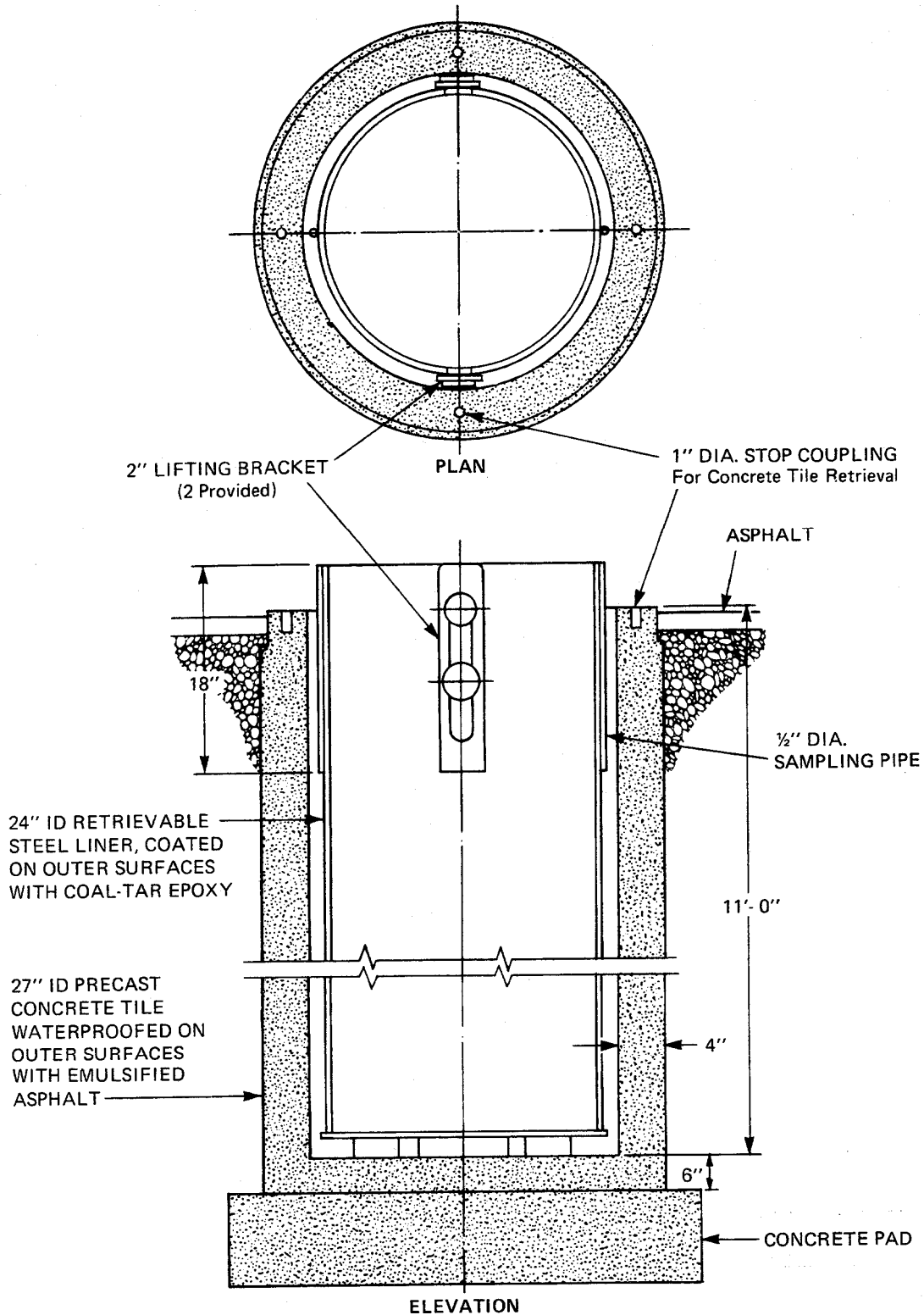

Report

OPG Proprietary		
Document Number:	00216-REP-03902-00003	Usage Classification: <b>INFORMATION</b>
Sheet Number:	Revision Number:	Page:
N/A	R003	120 of 136

Title:

**REFERENCE LOW- AND INTERMEDIATE-LEVEL WASTE INVENTORY FOR THE DEEP GEOLOGIC REPOSITORY**

<b>Container Description</b>	<p>Container name: Retube Waste Container (End Fitting)</p> <p>IWTS container code: RWC(EF)</p> <p>CATID: n/a</p> <p>Dimensions (m): 1.70 L x 3.35 W x 1.92 H</p> <p>External surface area (m<sup>2</sup>): 30.8</p> <p>Gross volume (m<sup>3</sup>): 10.9</p> <p>Net volume (m<sup>3</sup>): 2.7 <span style="float: right;">Picture n/a</span></p> <p>Material: Steel-concrete-steel construction</p> <p>Empty mass (kg): 29,200</p> <p>Max gross mass (kg): 33,500</p> <p>Stackability: 3 high</p> <p>Handling: Forklift</p>												
<b>Waste Properties</b>	<p>Typical contents: End fittings</p> <p>Typical composition: n/a</p> <p>Potential hazardous constituents: n/a</p> <p>Avg waste density (kg/m<sup>3</sup>): 966</p> <p>Contact Dose rate (mSv/h): &lt; 2 (design basis)</p> <p>Specific activity (Bq/m<sup>3</sup>): 4.3E+15</p> <p>Nominal Heat Load (watts/container): 5 yrs: 77; 10 yrs: 39</p>												
<b>Forecast Inventory</b>	<table border="1" style="width: 100%; border-collapse: collapse;"> <thead> <tr> <th></th> <th style="text-align: center;"><b>To 2018</b></th> <th style="text-align: center;"><b>To 2052</b></th> </tr> </thead> <tbody> <tr> <td>Number of containers:</td> <td style="text-align: center;">222</td> <td style="text-align: center;">899</td> </tr> <tr> <td>Total gross volume (m<sup>3</sup>):</td> <td style="text-align: center;">2,424</td> <td style="text-align: center;">9,804</td> </tr> <tr> <td>Total net volume (m<sup>3</sup>):</td> <td style="text-align: center;">600</td> <td style="text-align: center;">2,429</td> </tr> </tbody> </table>		<b>To 2018</b>	<b>To 2052</b>	Number of containers:	222	899	Total gross volume (m <sup>3</sup> ):	2,424	9,804	Total net volume (m <sup>3</sup> ):	600	2,429
	<b>To 2018</b>	<b>To 2052</b>											
Number of containers:	222	899											
Total gross volume (m <sup>3</sup> ):	2,424	9,804											
Total net volume (m <sup>3</sup> ):	600	2,429											
<b>Ref</b>	Dwg # AECL dwg 21RT-79150-002-1-GA												

**Note:** Container description for Bruce A 1 and 2 retube waste only. Additional shielding may be required for higher activity wastes from Bruce A 3 and 4, Bruce B, Pickering B, and Darlington.

Report

<b>OPG Proprietary</b>		
Document Number:	Usage Classification:	
<b>00216-REP-03902-00003</b>	<b>INFORMATION</b>	
Sheet Number:	Revision Number:	Page:
<b>N/A</b>	<b>R003</b>	<b>121 of 136</b>

Title:

**REFERENCE LOW- AND INTERMEDIATE-LEVEL WASTE INVENTORY FOR THE DEEP GEOLOGIC REPOSITORY**

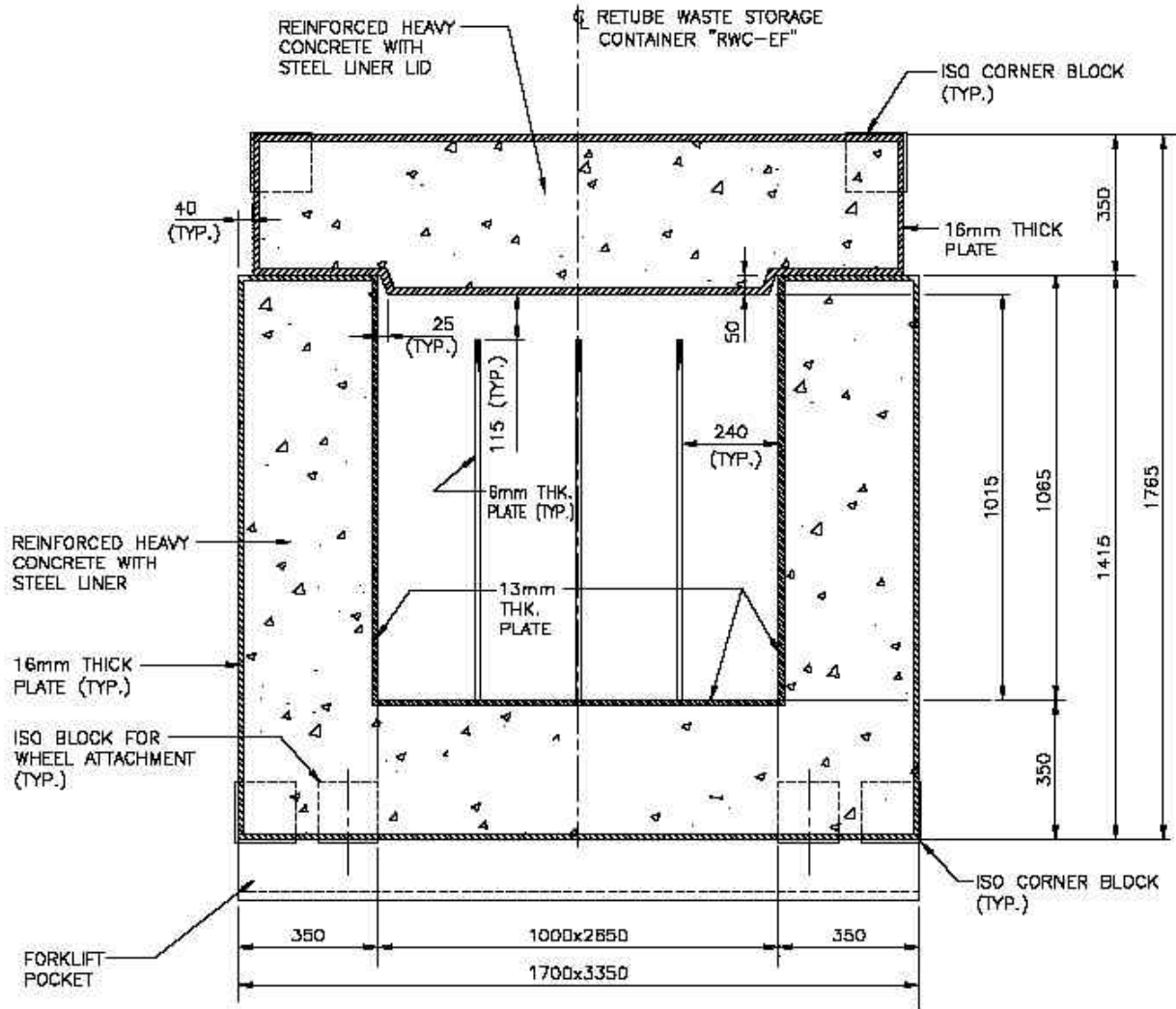

Bruce A Retube Waste Container (End Fitting) Sketch

Report

OPG Proprietary		
Document Number:	00216-REP-03902-00003	Usage Classification: <b>INFORMATION</b>
Sheet Number:	Revision Number: R003	Page: 122 of 136

Title:

**REFERENCE LOW- AND INTERMEDIATE-LEVEL WASTE INVENTORY FOR THE DEEP GEOLOGIC REPOSITORY**

<b>Container Description</b>	<p>Container name: Retube Waste Container (Pressure Tube)</p> <p>IWTS container code: RWC(PT)</p> <p>CATID: n/a</p> <p>Dimensions (m): 1.85 L x 1.85 W x 2.25 H</p> <p>External surface area (m<sup>2</sup>): 23.5</p> <p>Gross volume (m<sup>3</sup>): 7.7</p> <p>Net volume (m<sup>3</sup>): 0.8</p> <p>Material: Steel-concrete-steel construction</p> <p>Empty mass (kg): 26,600</p> <p>Max gross mass (kg): 29,100</p> <p>Stackability: 2 high</p> <p>Handling: Forklift</p>												
<b>Waste Properties</b>	<p>Typical contents: Pressure tubes, calandria tubes, or calandria tube inserts</p> <p>Typical composition: n/a</p> <p>Potential hazardous constituents: n/a</p> <p>Avg waste density (kg/m<sup>3</sup>): 2,288</p> <p>Contact Dose rate (mSv/h): &lt; 2 (design basis)</p> <p>Specific activity (Bq/m<sup>3</sup>): 1.1E+14 (CTs), 7.3E+13 (PTs), and 1.7E+15 (CTIs)</p> <p>Nominal Heat Load (watts/container):          Pressure tubes – 5 yrs: 9; 10 yrs: 7.5          Calandria tubes – 5 yrs: 7; 10 yrs: 2.6          Calandria tube inserts – 5 yrs: 45; 10 yrs: 23</p>												
<b>Forecast Inventory</b>	<table border="1"> <thead> <tr> <th></th> <th>To 2018</th> <th>To 2052</th> </tr> </thead> <tbody> <tr> <td>Number of containers:</td> <td>117</td> <td>454</td> </tr> <tr> <td>Total gross volume (m<sup>3</sup>):</td> <td>893</td> <td>3,494</td> </tr> <tr> <td>Total net volume (m<sup>3</sup>):</td> <td>92</td> <td>362</td> </tr> </tbody> </table>		To 2018	To 2052	Number of containers:	117	454	Total gross volume (m <sup>3</sup> ):	893	3,494	Total net volume (m <sup>3</sup> ):	92	362
	To 2018	To 2052											
Number of containers:	117	454											
Total gross volume (m <sup>3</sup> ):	893	3,494											
Total net volume (m <sup>3</sup> ):	92	362											
<b>Ref</b>	Dwg # AECL dwg 21RT-79150-001-1-GA-0 R0												

**Note:** Container description for Bruce A retube waste only. Additional shielding may be required for higher activity wastes from Bruce B, Pickering B, and Darlington.

Report

OPG Proprietary		
Document Number:	00216-REP-03902-00003	Usage Classification: INFORMATION
Sheet Number:	N/A	Revision Number: R003
		Page: 123 of 136

Title:

**REFERENCE LOW- AND INTERMEDIATE-LEVEL WASTE INVENTORY FOR THE DEEP GEOLOGIC REPOSITORY**

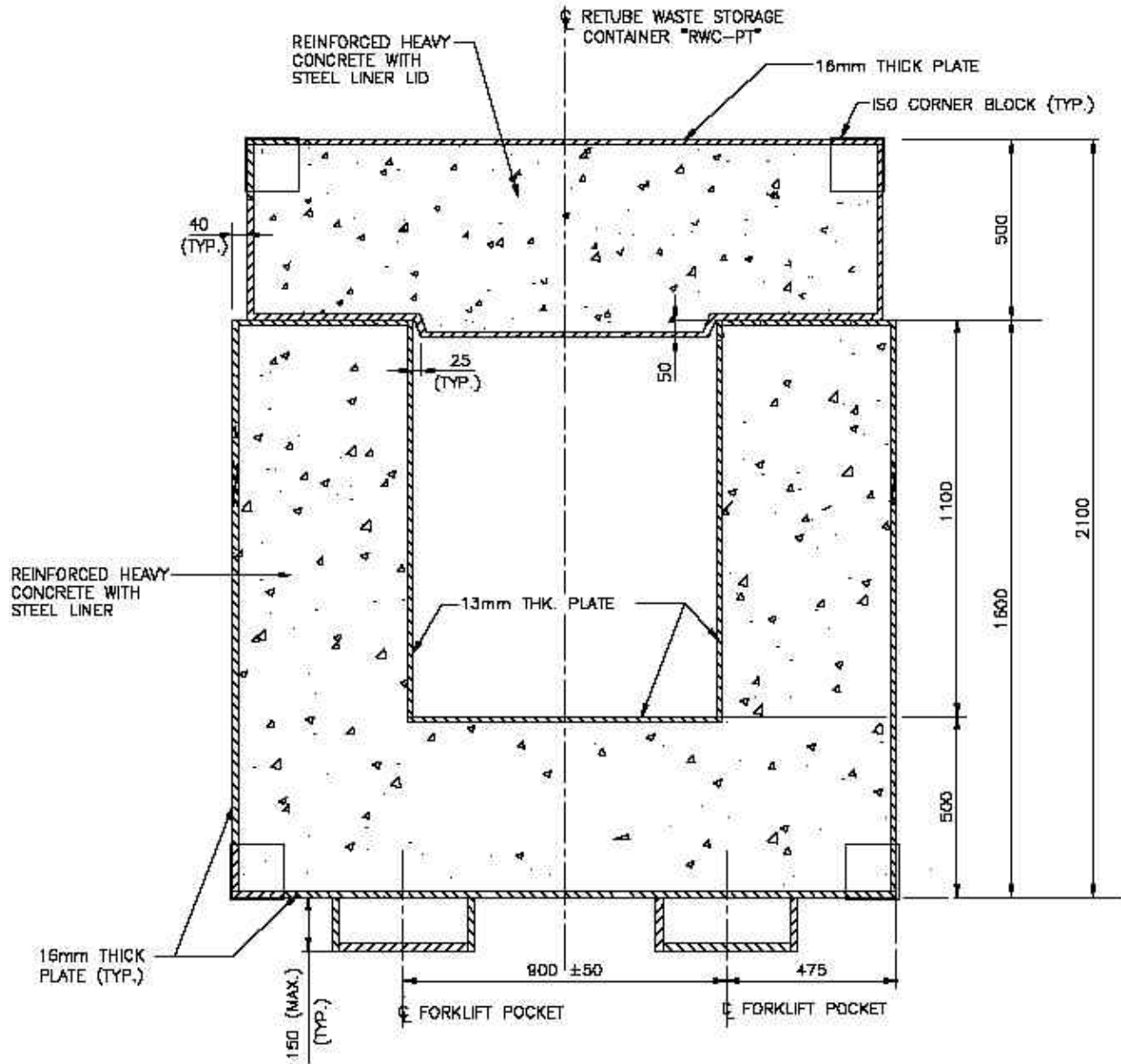

Bruce A Retube Waste Container (Pressure Tube) Sketch

**Report**

<b>OPG Proprietary</b>		
Document Number:	<b>00216-REP-03902-00003</b>	Usage Classification: <b>INFORMATION</b>
Sheet Number: <b>N/A</b>	Revision Number: <b>R003</b>	Page: <b>124 of 136</b>

Title:

**REFERENCE LOW- AND INTERMEDIATE-LEVEL WASTE INVENTORY FOR THE DEEP GEOLOGIC REPOSITORY**

<b>Container Description</b>	<p>Container name: Steam Generator (Bruce A)                  IWTS container code: SG(BA)                  CATID: n/a                  Dimensions (m): 2.6/2.4 OD x 11.7 OL                  External surface area (m<sup>2</sup>): n/a                  Gross volume (m<sup>3</sup>): 56                  Material: Carbon steel shell, high alloy steel tubes                  Empty mass (kg): 88,000                  Max gross mass (kg): n/a                  Stackability: Not stackable                  Handling: Heavy lift rigging, forklift</p>									
<b>Waste Properties</b>	<p>Typical contents: n/a                  Typical composition: n/a                  Potential hazardous constituents: n/a                  Avg waste density (kg/m<sup>3</sup>): 1,600                  Contact Dose rate (mSv/h): n/a                  Specific activity (Bq/m<sup>3</sup>): 3.1E+10</p>									
<b>Forecast Inventory*</b>	<table border="1" style="width: 100%; border-collapse: collapse;"> <thead> <tr> <th></th> <th style="text-align: center;"><b>To 2018</b></th> <th style="text-align: center;"><b>To 2052</b></th> </tr> </thead> <tbody> <tr> <td>Number of containers:</td> <td style="text-align: center;">32</td> <td style="text-align: center;">32</td> </tr> <tr> <td>Total gross volume (m<sup>3</sup>):</td> <td style="text-align: center;">1,803</td> <td style="text-align: center;">1,803</td> </tr> </tbody> </table>		<b>To 2018</b>	<b>To 2052</b>	Number of containers:	32	32	Total gross volume (m <sup>3</sup> ):	1,803	1,803
	<b>To 2018</b>	<b>To 2052</b>								
Number of containers:	32	32								
Total gross volume (m <sup>3</sup> ):	1,803	1,803								
<b>Ref</b>	Dwg # n/a									

\* Steam generators to be segmented into 5 pieces (SGSGMT).



Report

<b>OPG Proprietary</b>		
Document Number:	<b>00216-REP-03902-00003</b>	Usage Classification:
		<b>INFORMATION</b>
Sheet Number:	Revision Number:	Page:
<b>N/A</b>	<b>R003</b>	<b>125 of 136</b>

Title:

**REFERENCE LOW- AND INTERMEDIATE-LEVEL WASTE INVENTORY FOR THE DEEP GEOLOGIC REPOSITORY**

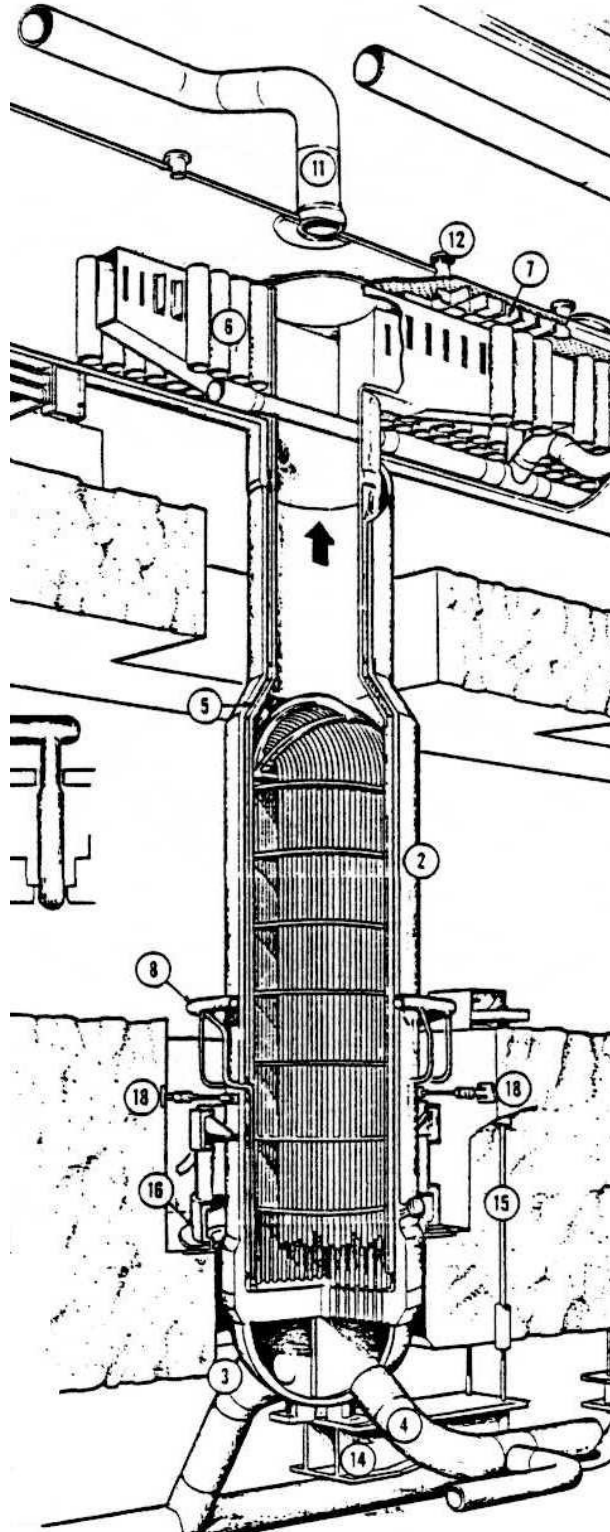

Report

OPG Proprietary		
Document Number:	00216-REP-03902-00003	Usage Classification: <b>INFORMATION</b>
Sheet Number:	Revision Number:	Page:
N/A	R003	126 of 136

Title:

**REFERENCE LOW- AND INTERMEDIATE-LEVEL WASTE INVENTORY FOR THE DEEP GEOLOGIC REPOSITORY**

<b>Container Description</b>	Container name: Steam Generator (Bruce B) IWTS container code: SG(BB) CATID: n/a Dimensions (m): 3.6/2.5 OD x 15.5 OL External surface area (m <sup>2</sup> ): n/a Gross volume (m <sup>3</sup> ): 131 <span style="float: right;">Picture n/a</span> Material: Carbon steel shell, high alloy steel tubes Empty mass (kg): 135,000 Max gross mass (kg): n/a Stackability: n/a Handling: Heavy lift rigging, forklift									
<b>Waste Properties</b>	Typical contents: n/a Typical composition: n/a Potential hazardous constituents: n/a Avg waste density (kg/m <sup>3</sup> ): 1,030 Contact Dose rate (mSv/h): n/a Specific activity (Bq/m <sup>3</sup> ): 3.1E+10									
<b>Forecast Inventory</b>	<table style="width: 100%; border-collapse: collapse;"> <thead> <tr> <th style="width: 60%;"></th> <th style="text-align: center; width: 20%;"><b>To 2018</b></th> <th style="text-align: center; width: 20%;"><b>To 2052</b></th> </tr> </thead> <tbody> <tr> <td>Number of containers:</td> <td style="text-align: center;">32</td> <td style="text-align: center;">32</td> </tr> <tr> <td>Total gross volume (m<sup>3</sup>):</td> <td style="text-align: center;">4,184</td> <td style="text-align: center;">4,184</td> </tr> </tbody> </table>		<b>To 2018</b>	<b>To 2052</b>	Number of containers:	32	32	Total gross volume (m <sup>3</sup> ):	4,184	4,184
	<b>To 2018</b>	<b>To 2052</b>								
Number of containers:	32	32								
Total gross volume (m <sup>3</sup> ):	4,184	4,184								
<b>Ref</b>	Dwg # n/a									

\* Steam generators to be segmented into 8 pieces (SGSGMT).

Report

OPG Proprietary		
Document Number:	00216-REP-03902-00003	Usage Classification: <b>INFORMATION</b>
Sheet Number:	N/A	Revision Number: R003
		Page: 127 of 136

Title:

**REFERENCE LOW- AND INTERMEDIATE-LEVEL WASTE INVENTORY FOR THE DEEP GEOLOGIC REPOSITORY**

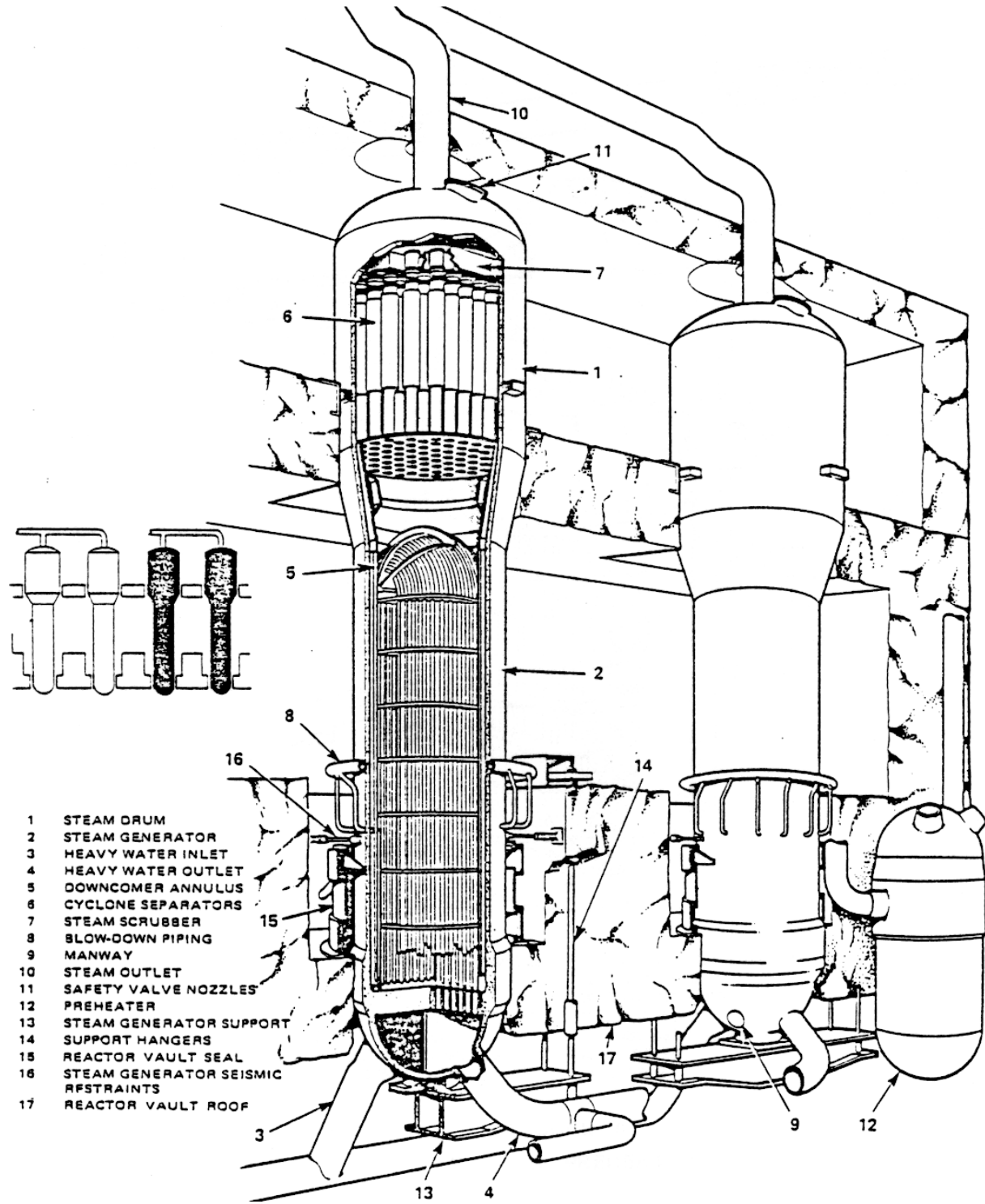

Report

OPG Proprietary		
Document Number:	00216-REP-03902-00003	Usage Classification: <b>INFORMATION</b>
Sheet Number: <b>N/A</b>	Revision Number: <b>R003</b>	Page: <b>128 of 136</b>

Title:

**REFERENCE LOW- AND INTERMEDIATE-LEVEL WASTE INVENTORY FOR THE DEEP GEOLOGIC REPOSITORY**

<b>Container Description</b>	Container name: Steam Generator (Pickering) IWTS container code: SG(P) CATID: n/a Dimensions (m): 2.5/1.8 OD x 14.3 OL External surface area (m <sup>2</sup> ): n/a Gross volume (m <sup>3</sup> ): 50 <span style="float: right;">Picture n/a</span> Material: Carbon steel shell, high alloy steel tubes Empty mass (kg): 85,000 Max gross mass (kg): n/a Stackability: n/a Handling: Heavy forklift rigging, forklift									
<b>Waste Properties</b>	Typical contents: n/a Typical composition: n/a Potential hazardous constituents: n/a Avg waste density (kg/m <sup>3</sup> ): 1,700 Contact Dose rate (mSv/h): n/a Specific activity (Bq/m <sup>3</sup> ): 3.1E+10									
<b>Forecast Inventory</b>	<table border="1" style="width: 100%; border-collapse: collapse;"> <thead> <tr> <th></th> <th style="text-align: center;"><b>To 2018</b></th> <th style="text-align: center;"><b>To 2052</b></th> </tr> </thead> <tbody> <tr> <td>Number of containers:</td> <td style="text-align: center;">48</td> <td style="text-align: center;">48</td> </tr> <tr> <td>Total gross volume (m<sup>3</sup>):</td> <td style="text-align: center;">2,400</td> <td style="text-align: center;">2,400</td> </tr> </tbody> </table>		<b>To 2018</b>	<b>To 2052</b>	Number of containers:	48	48	Total gross volume (m <sup>3</sup> ):	2,400	2,400
	<b>To 2018</b>	<b>To 2052</b>								
Number of containers:	48	48								
Total gross volume (m <sup>3</sup> ):	2,400	2,400								
<b>Ref</b>	Dwg # n/a									

\* Steam generators to be segmented into 6 pieces (SGSGMT).

Report

<b>OPG Proprietary</b>		
Document Number: <b>00216-REP-03902-00003</b>	Usage Classification: <b>INFORMATION</b>	
Sheet Number: <b>N/A</b>	Revision Number: <b>R003</b>	Page: <b>129 of 136</b>

Title:

**REFERENCE LOW- AND INTERMEDIATE-LEVEL WASTE INVENTORY FOR THE DEEP GEOLOGIC REPOSITORY**

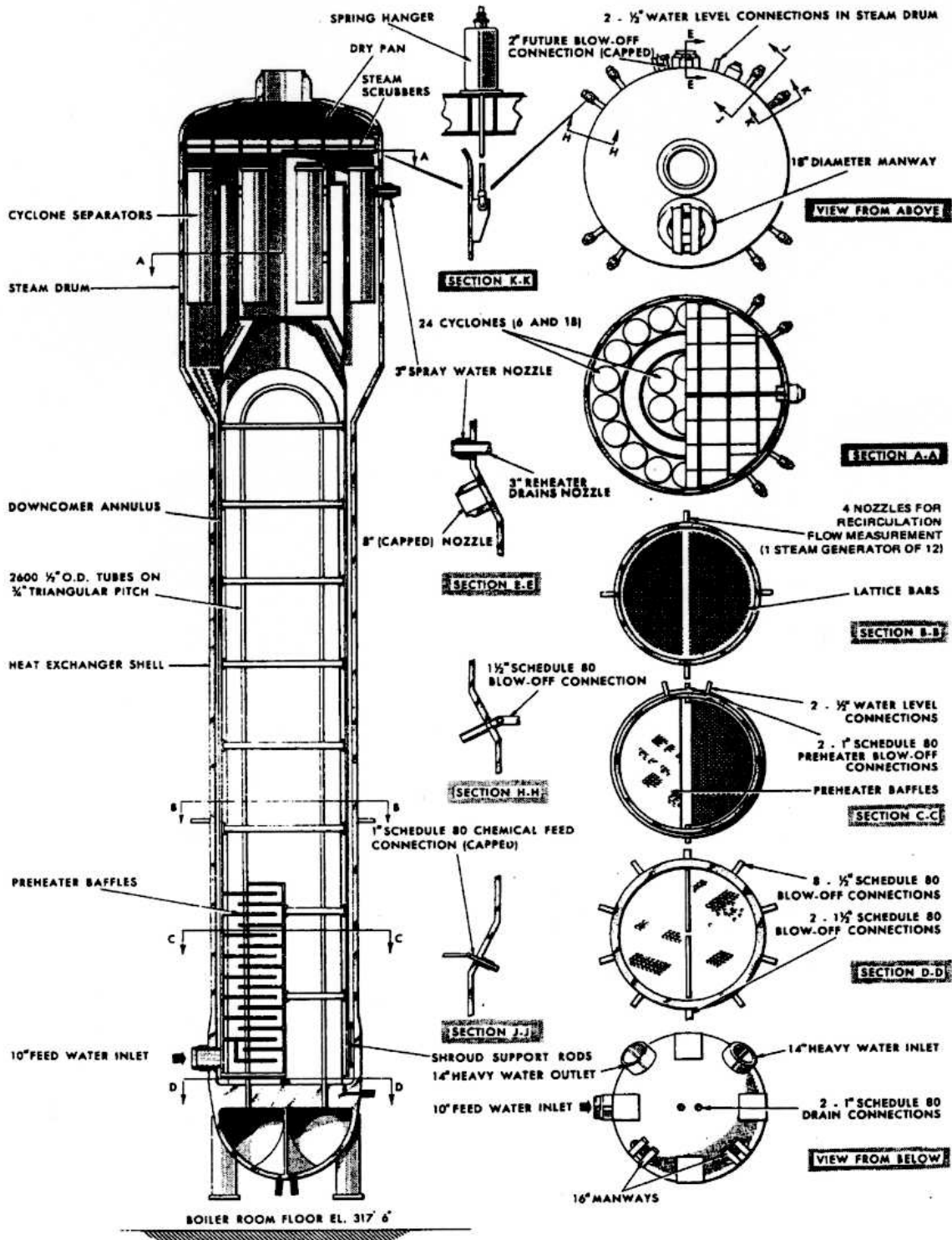

Report

OPG Proprietary		
Document Number:	00216-REP-03902-00003	Usage Classification: <b>INFORMATION</b>
Sheet Number: <b>N/A</b>	Revision Number: <b>R003</b>	Page: <b>130 of 136</b>

Title:

**REFERENCE LOW- AND INTERMEDIATE-LEVEL WASTE INVENTORY FOR THE DEEP GEOLOGIC REPOSITORY**

<b>Container Description</b>	<p>Container name: Steam Generator Segment</p> <p>IWTS container code: SGSGMT</p> <p>CATID: n/a</p> <p>Dimensions (m): 1.8-3.6 OD x 2.0-4.3 OL</p> <p>External surface area (m<sup>2</sup>): 43.6 (max)</p> <p>Gross volume (m<sup>3</sup>): 21.1 (max)</p> <p>Material: Carbon steel shell, high alloy steel tubes, grout backfill</p> <p>Empty mass (kg): n/a</p> <p>Max gross mass (kg): 25,730 (without grout)</p> <p>Stackability: n/a</p> <p>Handling: Heavy forklift</p>									
<b>Waste Properties</b>	<p>Typical contents: n/a</p> <p>Typical composition: n/a</p> <p>Potential hazardous constituents: n/a</p> <p>Avg waste density (kg/m<sup>3</sup>): n/a</p> <p>Contact Dose rate (mSv/h): n/a</p> <p>Specific activity (Bq/m<sup>3</sup>): 3.1E+10</p>									
<b>Forecast Inventory</b>	<table border="1"> <thead> <tr> <th></th> <th>To 2018</th> <th>To 2052</th> </tr> </thead> <tbody> <tr> <td>Number of containers:</td> <td>512</td> <td>512</td> </tr> <tr> <td>Total gross volume (m<sup>3</sup>):</td> <td>8,387</td> <td>8,387</td> </tr> </tbody> </table>		To 2018	To 2052	Number of containers:	512	512	Total gross volume (m <sup>3</sup> ):	8,387	8,387
	To 2018	To 2052								
Number of containers:	512	512								
Total gross volume (m <sup>3</sup> ):	8,387	8,387								
<b>Ref</b>	Dwg # n/a									

**Note:** Total mass includes grout weight.

**Report**

<b>OPG Proprietary</b>		
Document Number: <b>00216-REP-03902-00003</b>		Usage Classification: <b>INFORMATION</b>
Sheet Number: <b>N/A</b>	Revision Number: <b>R003</b>	Page: <b>131 of 136</b>

Title:

**REFERENCE LOW- AND INTERMEDIATE-LEVEL WASTE INVENTORY FOR THE DEEP GEOLOGIC REPOSITORY**

no drawing available

Report

OPG Proprietary		
Document Number:	00216-REP-03902-00003	Usage Classification: <b>INFORMATION</b>
Sheet Number:	Revision Number: R003	Page: 132 of 136

Title:

**REFERENCE LOW- AND INTERMEDIATE-LEVEL WASTE INVENTORY FOR THE DEEP GEOLOGIC REPOSITORY**

<b>Container Description</b>	<p>Container name: ILW Shield</p> <p>IWTS container code: n/a</p> <p>CATID: n/a</p> <p>Dimensions (m): 1.0 OD x 1.7 OL</p> <p>External surface area (m<sup>2</sup>): 6.9</p> <p>Gross volume (m<sup>3</sup>): 1.3</p> <p>Net volume (m<sup>3</sup>): 0.25</p> <p>Material: Concrete and steel</p> <p>Empty mass (kg): 2,015</p> <p>Max gross mass (kg): 2,290</p> <p>Stackability: Several</p> <p>Handling: Forklift</p> <p style="text-align: right;">Picture n/a</p>												
<b>Waste Properties</b>	<p>Typical contents: Filters, IX columns, bagged wastes, and core components</p> <p>Typical composition: n/a</p> <p>Potential hazardous constituents: n/a</p> <p>Avg waste density (kg/m<sup>3</sup>): 1,100</p> <p>Contact Dose rate (mSv/h): &lt; 2 (design basis)</p> <p>Specific activity (Bq/m<sup>3</sup>): n/a</p>												
<b>Forecast Inventory</b>	<table border="1"> <thead> <tr> <th></th> <th>To 2018</th> <th>To 2052</th> </tr> </thead> <tbody> <tr> <td>Number of containers:</td> <td>0</td> <td>3,952</td> </tr> <tr> <td>Total gross volume (m<sup>3</sup>):</td> <td>0</td> <td>5,137</td> </tr> <tr> <td>Total net volume (m<sup>3</sup>):</td> <td>0</td> <td>988</td> </tr> </tbody> </table>		To 2018	To 2052	Number of containers:	0	3,952	Total gross volume (m <sup>3</sup> ):	0	5,137	Total net volume (m <sup>3</sup> ):	0	988
	To 2018	To 2052											
Number of containers:	0	3,952											
Total gross volume (m <sup>3</sup> ):	0	5,137											
Total net volume (m <sup>3</sup> ):	0	988											
<b>Ref</b>	Dwg # n/a												

**Note:** Design under review.



**Report**

<b>OPG Proprietary</b>		
Document Number: <b>00216-REP-03902-00003</b>		Usage Classification: <b>INFORMATION</b>
Sheet Number: <b>N/A</b>	Revision Number: <b>R003</b>	Page: <b>133 of 136</b>

Title:

**REFERENCE LOW- AND INTERMEDIATE-LEVEL WASTE INVENTORY FOR THE DEEP GEOLOGIC REPOSITORY**

no drawing available

## Report

OPG Proprietary		
Document Number:	00216-REP-03902-00003	Usage Classification: <b>INFORMATION</b>
Sheet Number:	Revision Number: <b>R003</b>	Page: <b>134 of 136</b>

Title:

## REFERENCE LOW- AND INTERMEDIATE-LEVEL WASTE INVENTORY FOR THE DEEP GEOLOGIC REPOSITORY

### Glossary

**CANDECON:** A chemical decontamination process for nuclear heat transport systems. Wastes produced from this process are contaminated resins and filters, which contain high levels of chelating agents such as EDTA.

**Compactable Waste:** Wastes which can be processed by medium force compaction, such as light metal objects, insulation materials, hoses, cables, metal fillings and turnings etc. with a contact dose rate less than 2 mSv/h (200 mrem/hr).

**Decommissioning:** Transforming a facility and its site, after the operational period is concluded, into a safe and socially acceptable state.

**Disposal:** The emplacement of waste in an appropriate facility without the intention of retrieval.

**Emplaced Volume:** The external volume of the waste package for emplacement in the DGR, which includes the waste, storage container, overpack, and/or shield.

**Filter:** Depending on each specific station system, filter waste may consist of disposable vessels along with the exhausted filter cartridges contained therein, or filter cartridges from systems employing permanent vessels.

**Gross Volume:** Refers to container volume based on external dimensions.

**Intermediate-Level Waste (ILW):** Radioactive non-fuel waste containing significant quantities of long-lived radionuclides (generally refers to half-lives greater than 30 years). ILW often requires shielding for worker protection during handling.

**Incinerable Waste:** Radioactive waste materials generally consisting of paper, plastic, wood, cardboard etc. which can be incinerated. The contact dose rate of such waste is less than 0.6 mSv/h (60 mrem/hr).

**In-Ground Storage:** Storage of waste in in-ground storage containers (ICs) generally used for intermediate level waste. All ICs with the exception of those used for heat exchangers (HXs) consist of steel liners fixed with concrete inside bore-holes in the ground. IC-HXs use limestone gravel for the backfill.

**In-Service Date:** The date on which the facility is put into service or made available for operation.

**IX-Resin:** Ion-exchange resin used to maintain the water quality in station process systems (e.g., moderator and PHT heavy water systems, and light water auxiliary systems such as the Active Liquid Waste Treatment System).

**Irradiated Core Components:** Radioactive waste such as flux detectors and liquid zone control rods resulting from the routine replacement of such core components during the operation of nuclear reactors.

Report

OPG Proprietary		
Document Number:	00216-REP-03902-00003	Usage Classification: <b>INFORMATION</b>
Sheet Number:	Revision Number: R003	Page: 135 of 136

Title:

**REFERENCE LOW- AND INTERMEDIATE-LEVEL WASTE INVENTORY FOR THE DEEP GEOLOGIC REPOSITORY**

**Liquid Waste:** Radioactive waste in liquid form, which may contain dissolved, colloidal or dispersed solids. Because liquids are mobile and dispersible, treatment by incineration, drying or solidification is generally carried out prior to storage.

**Low-Level Waste (LLW):** Radioactive waste in which the concentration or quantity of radionuclides is above the clearance levels established by the regulatory body (CNSC), and which contains primarily short-lived radionuclides (half-lives shorter than or equal to 30-years). LLW normally does not require shielding for worker protection during handling.

**Low-Level Storage Building:** Buildings at the WWMF used for storing low level radioactive waste.

**Max Gross Mass:** Maximum allowable weight of container, including container and contents.

**Net Volume:** The internal volume of the container in which the waste is stored.

**Non-processible Waste:** Wastes that are neither incinerable nor compactable, such as heavy gauge metal objects, glass, concrete, tools, heavy slings and cables.

**Retube Waste:** Radioactive waste produced from the fuel channel replacement (retubing) program i.e., pressure tubes, calandria tubes, end fittings, yokes and studs.

**Scaling Factor:** A ratio relating the activity of “difficult-to-measure” radionuclide (e.g., Pu-239, Pu-241) to the activity of an “easy-to-measure” radionuclide (e.g., Co-60, Cs-137).

**Storage:** The placement of waste in a facility where isolation, environmental protection and human control, i.e., monitoring, are provided with the intent that the waste will be retrieved for processing and/or disposal at a later time.

**Stored Volume:** The external volume of the storage container in which the waste is currently stored (same as “Gross Volume”). This volume does not include overpacks or concrete shields which may be required for repository emplacement.

**Waste Acceptance Criteria (WAC):** Formal criteria which define the qualities of waste packages (including the waste) that are accepted for disposal in the repository.

**Waste Arisings:** Amount of waste produced at the stations, prior to any waste conditioning.

**Waste Characterisation:** Activities to define the physical, chemical and radiological characteristics of the radioactive waste.

**Waste Conditioning:** Those operations that produce a waste package suitable for handling, transport, storage and/or disposal. Conditioning may include the conversion of the waste to a solid waste form, enclosure of the waste in containers, and, if necessary, providing an overpack.

**Waste Management:** All activities, administrative and operational, that are involved in the handling, pre-treatment, treatment, conditioning, transportation, storage and disposal of waste from a nuclear facility.

Report

<b>OPG Proprietary</b>		
Document Number:	<b>00216-REP-03902-00003</b>	Usage Classification:
		<b>INFORMATION</b>
Sheet Number:	Revision Number:	Page:
<b>N/A</b>	<b>R003</b>	<b>136 of 136</b>

Title:

**REFERENCE LOW- AND INTERMEDIATE-LEVEL WASTE INVENTORY FOR THE DEEP GEOLOGIC REPOSITORY**

***Waste Volume Reduction Building:*** The building at the WWMF containing waste volume reduction equipment (i.e., incinerator and compactor).

***Western Waste Management Facility (WWMF):*** The centralized processing and storage facility for OPG's low and intermediate level radioactive wastes, and the dry storage facility for used fuel from the Bruce nuclear generating stations.